

BURNHAM®

Commercial Boilers

RATINGS AND DATA

Shell Diameter : 48"
 Gross Output - BHP : 51
 Gross Output - MBH : 1707
 Gross Output - Lbs/Hr : 1760
 Net Rating - MBH : 1317
 Net Rating - Sq. Ft. : 5488
 Safety Valve - Lbs/Hr. : 2000

Heating Surface - Sq. Ft.
 Fireside - 250
 Firetubes
 Number - 92
 Diameter - 2" O.D.

Firing Rate
 1000 BTU Gas (MBH) - 2092
 140000 BTU/Gal Oil (GPH) - 14.5
 150000 BTU/Gal Oil (GPH) - 13.5

Water Content
 Pounds - 2293
 Gallons (U.S.) - 275
 Approximate Weight/LBS.
 Dry - 4380
 Wet - 6673

LEGEND

BS = BOTH SIDES
 RS = RIGHT SIDE

LEGEND CONNECTIONS

- A = 6" FLANGED SUPPLY (150)
- B = 3" RETURN
- C = 3" x 4" HANDHOLE
- D = 1" WATER COLUMN
- E = 3/4" AQUASTAT/LFHA
- F = 1-1/2" BOTTOM BLOWDOWN
- G = 1-1/2" SURFACE BLOWOFF
- H = 1-1/2" AUXILIARY CONNECTION
- J = 2" SAFETY VALVE
- K = 10" NOMINAL FLUE DIAMETER

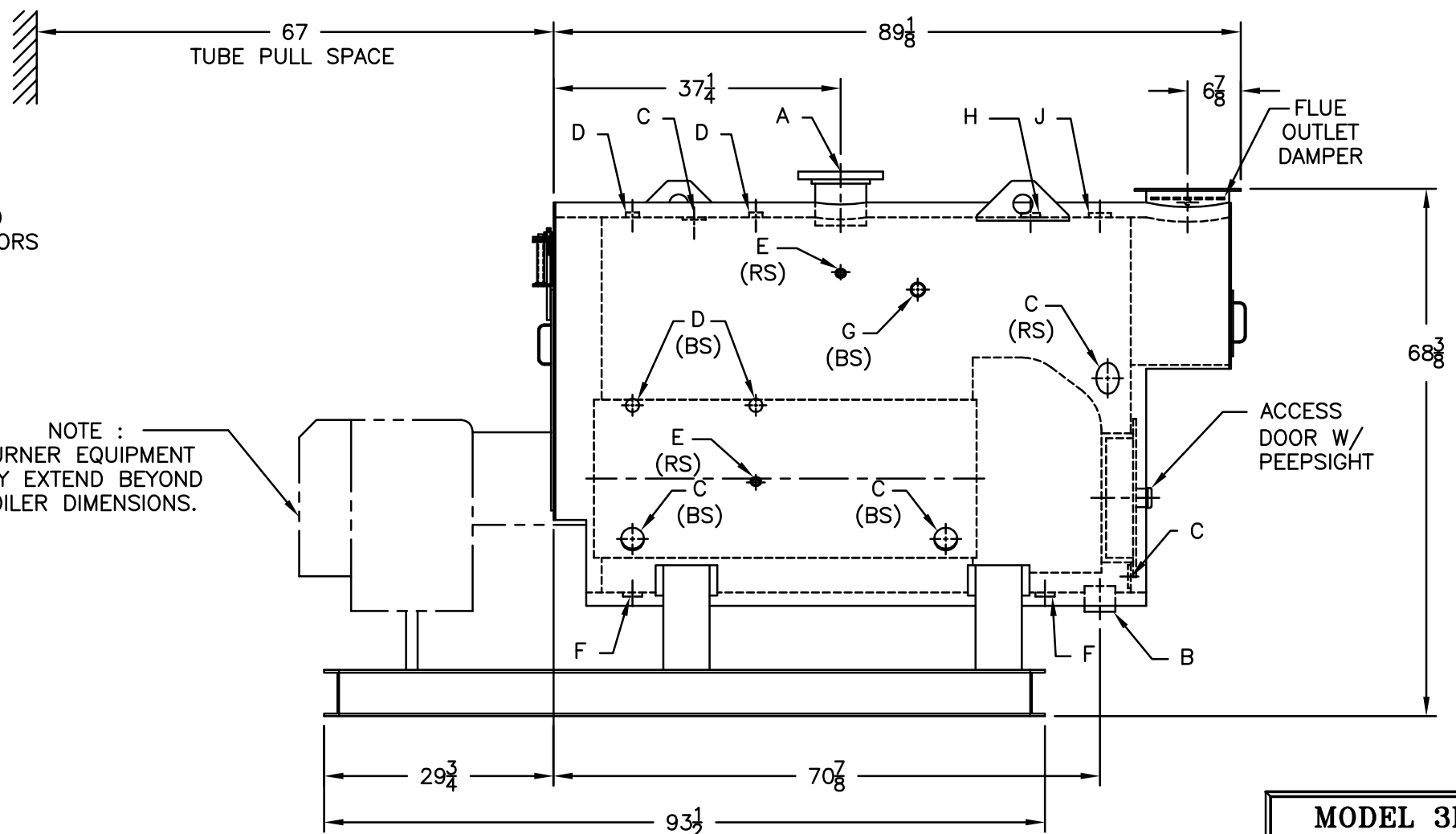
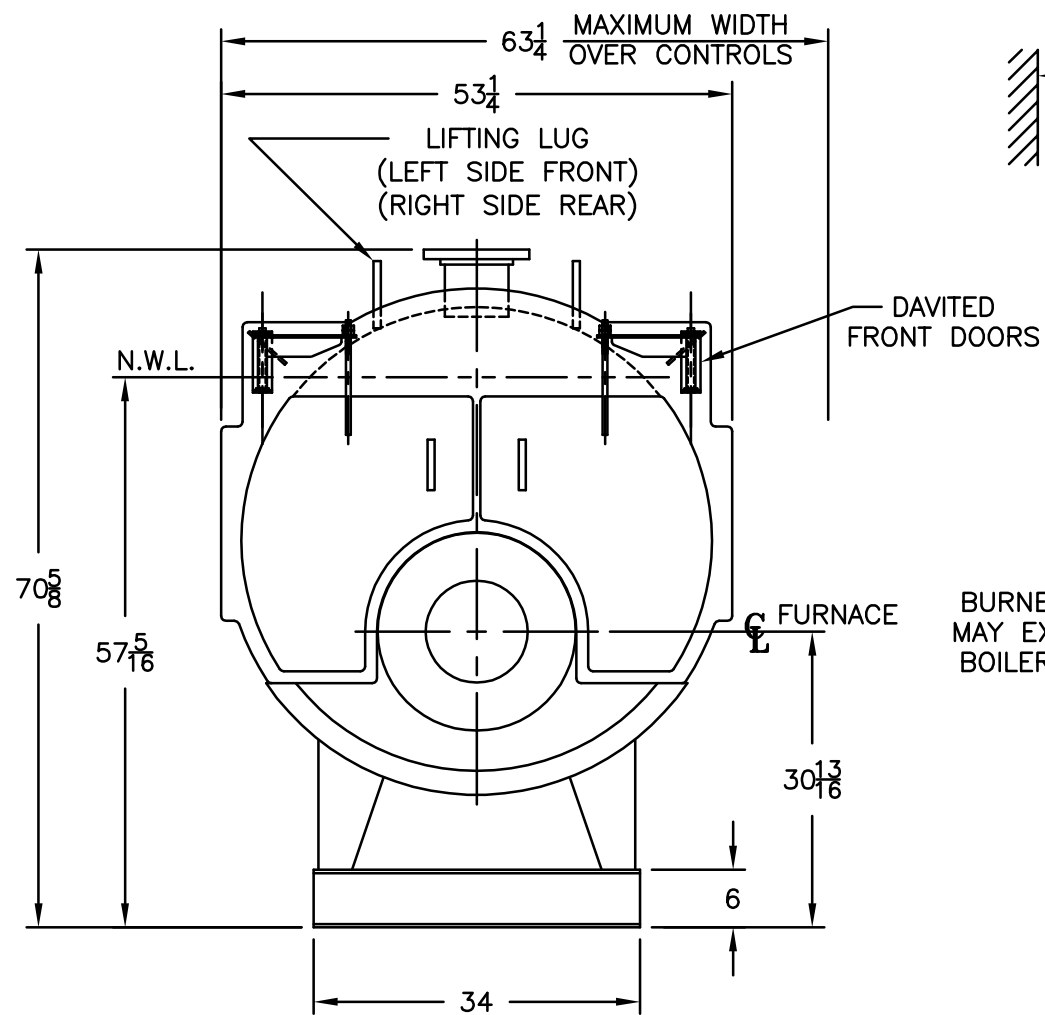
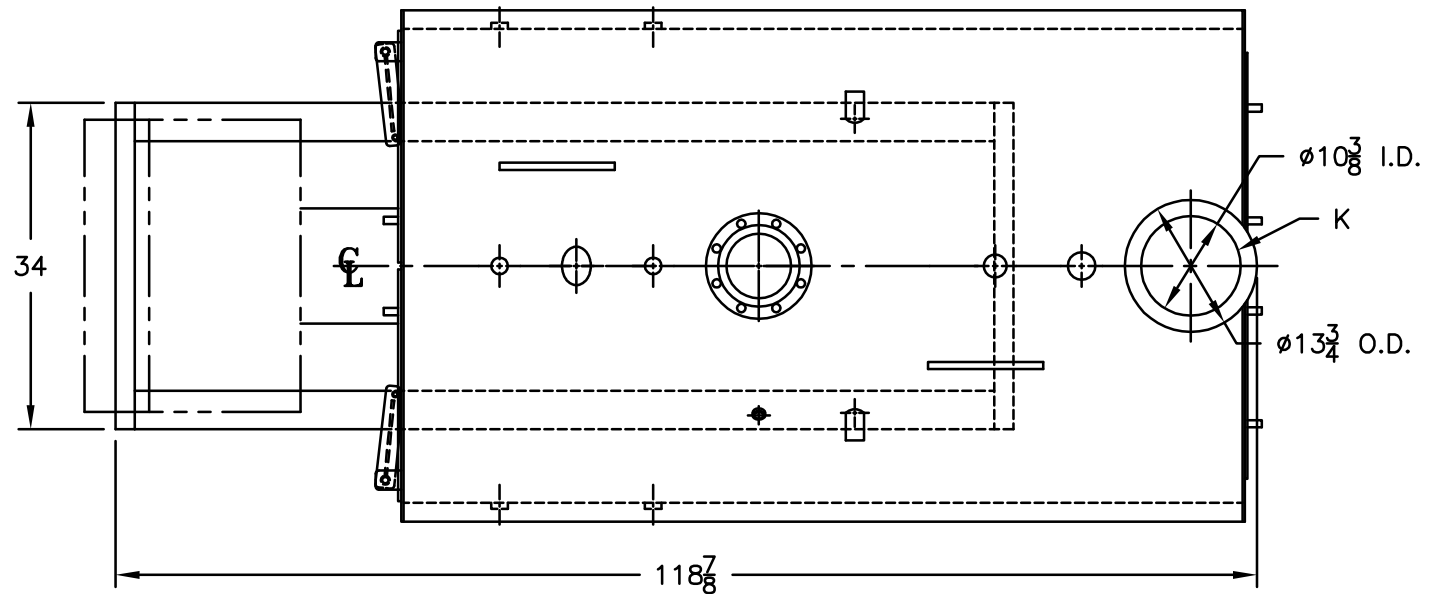

SPECIFICATIONS SUBJECT TO CHANGE WITHOUT NOTICE ALL CONNECTIONS ARE THREADED UNLESS OTHERWISE SPECIFIED
 THIS DOCUMENT CONTAINS CONFIDENTIAL INFORMATION WHICH IS THE PROPERTY OF BURNHAM COMMERCIAL. THIS DOCUMENT MAY NOT BE REPRODUCED, TRANSFERRED OR USED, OR ITS CONTENTS DISCLOSED, WITHOUT THE WRITTEN PERMISSION OF THE OWNER.

MODEL 3L-50
51 BHP
15 PSI STEAM