

**Date: October 24, 2012****Bulletin Number: HP607****Subject: Explanation of V9-V11 Rope Groove**

In an effort to clarify the differences between the types of casting groove changes that took place in the fall of 2004 it is important to understand the definition of the type of groove and the year the casting was manufactured. This groove, located on the outer edge of the section is there to provide a seal to keep the products of combustion from leaking out between the sections.

Prior to 2004, this sealing groove was known as the "V" groove. The "V" groove, was a small, "V" shaped groove that was cast into the outer edge of the casting and was originally meant to be filled with silastic sealant only, without the use of any rope.

After 2004, we began machining the "G" groove. The "G" groove is a much larger and deeper rounded  $\frac{1}{2}$ " groove cast into the outer edge of the section.

During the development of the rope groove seal, we also designed an  $\frac{1}{8}$ " rope that would fit all the old "V" groove style joints. This was done as an upgrade to the old style "V" groove in case someone wanted to use it instead of just silastic sealant.

Three different rope diameters are used, depending on the type of joint the rope is being applied to. The  $\frac{1}{4}$ " rope is for use on the "V" to "G" groove joint (See figure A). The  $\frac{3}{8}$ " rope is used when you have a "G" to "G" groove joint (See figure B). The  $\frac{1}{8}$ " rope is only for use with a "V" to "V" type joint (See figure C).

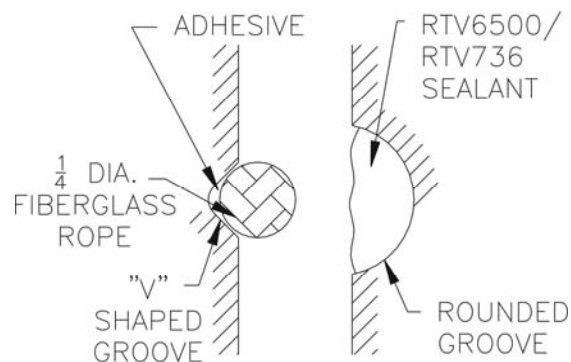

Figure A – "V" to "G" joint

Date: October 24, 2012

Bulletin Number: HP607

Subject: Explanation of V9-V11 Rope Groove

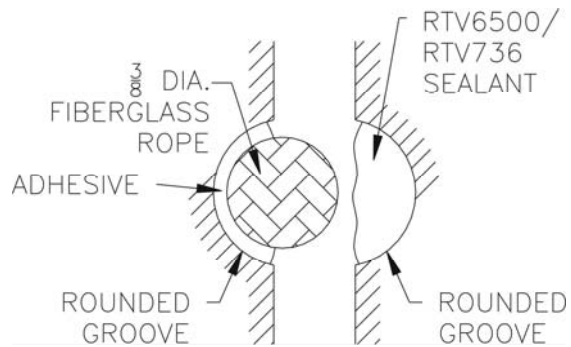

Figure B – “G” to “G” joint

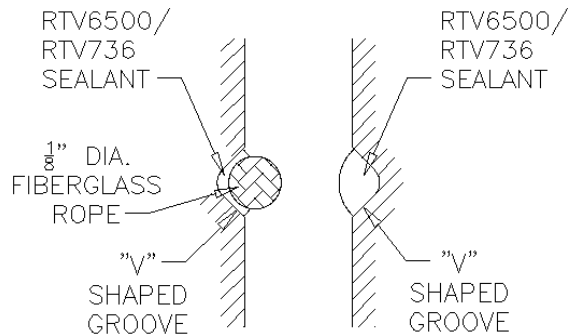

Figure C – “V” to “V” joint

Please refer to the Single Joint Assembly Instructions for V9/V11 Boiler Sections, part # 81460397R2 for complete instructions on how to apply the rope to the section, or consult the V9-V11 manual. Please refer to the “V” Groove Single Joint Assembly Instructions, part # 81460404 for how to apply the 1/8” rope on “V” to “V” groove sections.