

Series 8HE

<u>Manual Contents</u>	<u>Page</u>
1. Pre-Installation.....	6
2. Boiler Assembly.....	9
3. Water Trim and Piping.....	17
4. Gas Piping.....	22
5. Venting.....	24
6. Electrical.....	27
7. System Start-up.....	30
8. Service.....	34
9. Service Parts.....	40

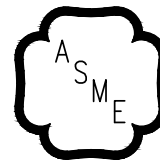

Intertek

H

⚠ WARNING

This manual must only be used by a qualified heating installer/service technician. BEFORE installing, read all instructions in this manual and all other information shipped with the boiler. Post all instructions and manuals near the boiler for reference by service personnel. Perform steps in the order given. Failure to comply could result in severe personal injury, death or substantial property damage.



www.burnhamcommercial.com

IMPORTANT INFORMATION - READ AND SAVE THESE INSTRUCTIONS FOR REFERENCE

All boilers must be installed in accordance with National, State and Local Plumbing, Heating and Electrical Codes and the regulations of the serving utilities. These Codes and Regulations may differ from this instruction manual. Authorities having jurisdiction should be consulted before installations are made. In all cases, reference should be made to the following Standards:

- A. Current Edition of National Fuel Gas Code, NFPA 54/ANSI Z223.1.
- B. Current Edition of American National Standard ANSI/NFPA 211, "Chimneys, Fireplaces, Vents, and Solid Fuel Burning Appliances"; For Venting requirements.
- C. Current Edition of American Society of Mechanical Engineers ASME CSD-1, "Controls and Safety Devices for Automatically Fired Boilers"; for assembly and operations of controls and safety devices.
- D. All wiring on boilers installed in the USA shall be made in accordance with the National Electrical Code, NFPA 70, and/or Local Regulations.

Hazard Definitions

The following defined terms are used throughout this manual to bring attention to the presence of hazards of various risk levels or to important information concerning the life of the product.

DANGER

Indicates a hazardous situation that, if not avoided, will result in death or serious injury.

CAUTION

Indicates a hazardous situation that, if not avoided, could result in minor or moderate injury.

WARNING

Indicates a hazardous situation that, if not avoided, could result in death or serious injury.

NOTICE: Indicates special instructions on installation, operation, or service which are important but not related to personal injury hazards.

 **DANGER****• Explosion Hazard.**

- DO NOT store or use gasoline or other flammable vapors or liquids in the vicinity of this or any other appliance.
- If you smell gas, do not try to operate the burner/boiler system. Do not touch any electrical switch or use any phone in the building. Immediately call the gas supplier from a remotely located phone
- Burner/boiler systems produce steam or hot water in a pressurized vessel by mixing extremely flammable fuels with air to produce combustion and very hot products of combustion. Explosions, fires, severe personal injury, death and/or property damage will result from improper, careless or inadequate installation, operation or maintenance of fuel-burning and boiler equipment.

 **WARNING**

- This boiler requires regular maintenance and service to operate safely. Follow the instructions contained in this manual.
- Improper installation, adjustment, alteration, service or maintenance can cause property damage, personal injury or loss of life. Read and understand the entire manual before attempting installation, start-up operation, or service. Installation and service must be performed only by an knowledgeable, experienced, and skilled installer or service agency.
- This boiler must be properly vented.
- This boiler needs fresh air for safe operation and must be installed so there are provisions for adequate combustion and ventilation air.
- The interior of the venting system must be inspected and cleaned before the start of the heating season and should be inspected periodically throughout the heating season for any obstructions. A clean and unobstructed venting system is necessary to allow noxious fumes that could cause injury or loss of life to vent safely and will contribute toward maintaining the boiler's efficiency.
- Installation is not complete unless a pressure relief valve is installed into the specified tapping on the supply top of appliance - See Section 3, Paragraph C.
- This boiler is supplied with safety devices which may cause the boiler to shut down and not re-start without service. If damage due to frozen pipes is a possibility, the heating system should not be left unattended in cold weather; or appropriate safeguards and alarms should be installed on the heating system to prevent damage if the boiler is inoperative.
- This boiler contains very hot water under high pressure. Do not unscrew any pipe fittings nor attempt to disconnect any components of this boiler without positively assuring the water is cool and has no pressure. Always wear protective clothing and equipment when installing, starting up or servicing this boiler to prevent scald injuries. Do not rely on the pressure and temperature gauges to determine the temperature and pressure of the boiler.
- This boiler contains components which become very hot when the boiler is operating. Do not touch any components unless they are cool.
- Boiler materials of construction, products of combustion and the fuel contain alumina, silica, heavy metals, carbon monoxide, nitrogen oxides, aldehydes and/or other toxic or harmful substances which can cause death or serious injury and which are known to the state of California to cause cancer, birth defects and other reproductive harm. Always use proper safety clothing, respirators and equipment when servicing or working nearby the appliance.
- Failure to follow all instructions in the proper order can cause personal injury or death. Read all instructions, including all those contained in component manufacturers manuals which are provided with the boiler before installing, starting up, operating, maintaining or servicing.
- Keep boiler area clear and free from combustible materials, gasoline and other flammable vapors or liquids.
- Do not operate boiler with control which has been subject to water.
- All cover plates, enclosures and guards must be in place at all times.

⚠ WARNING

- Keep boiler area clear and free from combustible materials, gasoline, and other flammable vapors and liquids.
- This boiler requires regular maintenance and service to operate safely. Follow the instructions contained in this manual.
- Installation, maintenance, and service must be performed only by an experienced, skilled and knowledgeable installer or service agency.
- All heating systems should be designed by competent contractors and only persons knowledgeable in the layout and installation of heating systems should attempt installation of any boiler.
- It is the responsibility of the installing contractor to see that all controls are correctly installed and are operating properly when the installation is completed.
- Installation is not complete unless a pressure relief valve is installed.
- This boiler is NOT suitable for installation on combustible flooring.
- Do not tamper with or alter the boiler or controls. Retain your contractor or a competent serviceman to assure that the unit is properly adjusted and maintained.
- Service boiler at least once a year - preferably at the start of the heating season. The inside of the combustion chamber should also be inspected at the same time. Clean if necessary.
- Have Burner and Controls checked at least once a year or as may be necessitated. Do not operate unit with jumpered or absent controls or safety devices. Do not operate unit if any control, switch, component, or device has been subject to water.
- This boiler is designed to burn natural gas only. Do not use gasoline, crankcase drainings, or any oil containing gasoline. Never burn garbage or paper in this boiler. Do not convert to any solid fuel (i.e. wood, coal). All flammable debris, rags, paper, wood scraps, etc., should be kept clear of the boiler at all times. Keep the boiler area clean and free of fire hazards.

NOTICE:

1. This boiler has a limited warranty, a copy of which is printed on the back of this manual. It is the responsibility of the installing contractor to see that all controls are correctly installed and are operating properly when the installation is complete. The warranty for this boiler is valid only if the boiler has been installed, maintained and operated in accordance with these instructions.
2. Boilers built for installation at altitudes 2,000-5,000 ft. above sea level have been specially orificed to reduce gas input rate 4 percent per 1,000 feet above sea level per the National Fuel Gas Code, NFPA 54/ANSI Z223.1.
3. All Series 8HE cast iron boilers are designed, built, marked and tested in accordance with the ASME Boiler and Pressure Vessel Code, Section IV, Heating Boilers. An ASME Data Label is factory applied to each 8HE jacket, which indicates the boiler Maximum Allowable working Pressure (MAWP). Each cast iron section is permanently marked with the MAWP listed on the boiler's ASME Data Label. The MAWP for all Series 8HE Boiler is 50 psi (Water Only).

It is common and acceptable practice to install these boilers in lower pressure systems, below the boiler MAWP. Therefore, in addition to Safety Relief Valves set for 50 psi, Burnham Commercial also offers Safety Relief Valves set for 30 psi (By Special Order Only).

Important Product Safety Information: Refractory Ceramic Fiber Product

WARNING

Some boiler components use materials that contain refractory ceramic fibers (RCF). RCF has been classified as a possible human carcinogen. When exposed to elevated temperatures, RCF may change into crystalline silica, a known carcinogen. When disturbed as a result of servicing or repair, these substances become airborne and, if inhaled, may be hazardous to your health. Avoid breathing RCF particulates and dust.

Precautionary Measures:

- Do not handle RCF parts or attempt any service or repair work involving RCF without wearing the following protective gear:
 1. A properly fitting National Institute for Occupational Safety and Health (NIOSH)-certified air-purifying respirator with a filter efficiency of at least 95%. Respirator should also include a full facepiece when handling used RCF. Other types of respirators may be required depending on site conditions. Current NIOSH recommendations may be found on the NIOSH website <http://www.cdc.gov/niosh/homepage.html>. NIOSH-approved manufacturers, respirators and associated user instructions are listed on the NIOSH website.
 2. Long sleeved, loose fitting clothing that is sufficiently tight around potential entry points for RCF dust.
 3. Gloves.
 4. Eye protection, such as goggles, safety glasses with side shields, or full facepiece.
- Take steps to assure adequate ventilation.
- Handle RCF carefully to minimize airborne dust. Use hand tools whenever possible.
- Dampen used RCF with light water spray prior to removal to prevent airborne dust.
- Do not use compressed air or dry sweeping for clean-up. Frequently clean work area with a vacuum or by wet sweeping to minimize debris accumulation.
- Vacuum work clothes before leaving work area. Wash work clothes separately from other laundry and rinse washing machine after use to avoid contaminating other clothes.
- Wash all exposed body areas gently with soap and water after contact.
- Discard used RCF components by sealing in an airtight plastic bag or container. Refer to local, regional, state or provincial regulations to identify applicable disposal requirements.

First Aid Procedures:

- Eye contact: Flush with water for at least 15 minutes. **Do not rub eyes.** Seek immediate medical attention if irritation persists.
- Skin contact: Wash affected area gently with soap and water. Do not rub or scratch affected skin. Seek immediate medical attention if irritation persists.
- Nose and throat contact: If these become irritated, leave the area and move to a location with clean fresh air. Drink water and blow nose. Seek immediate medical attention if symptoms persist.

1 Pre-Installation

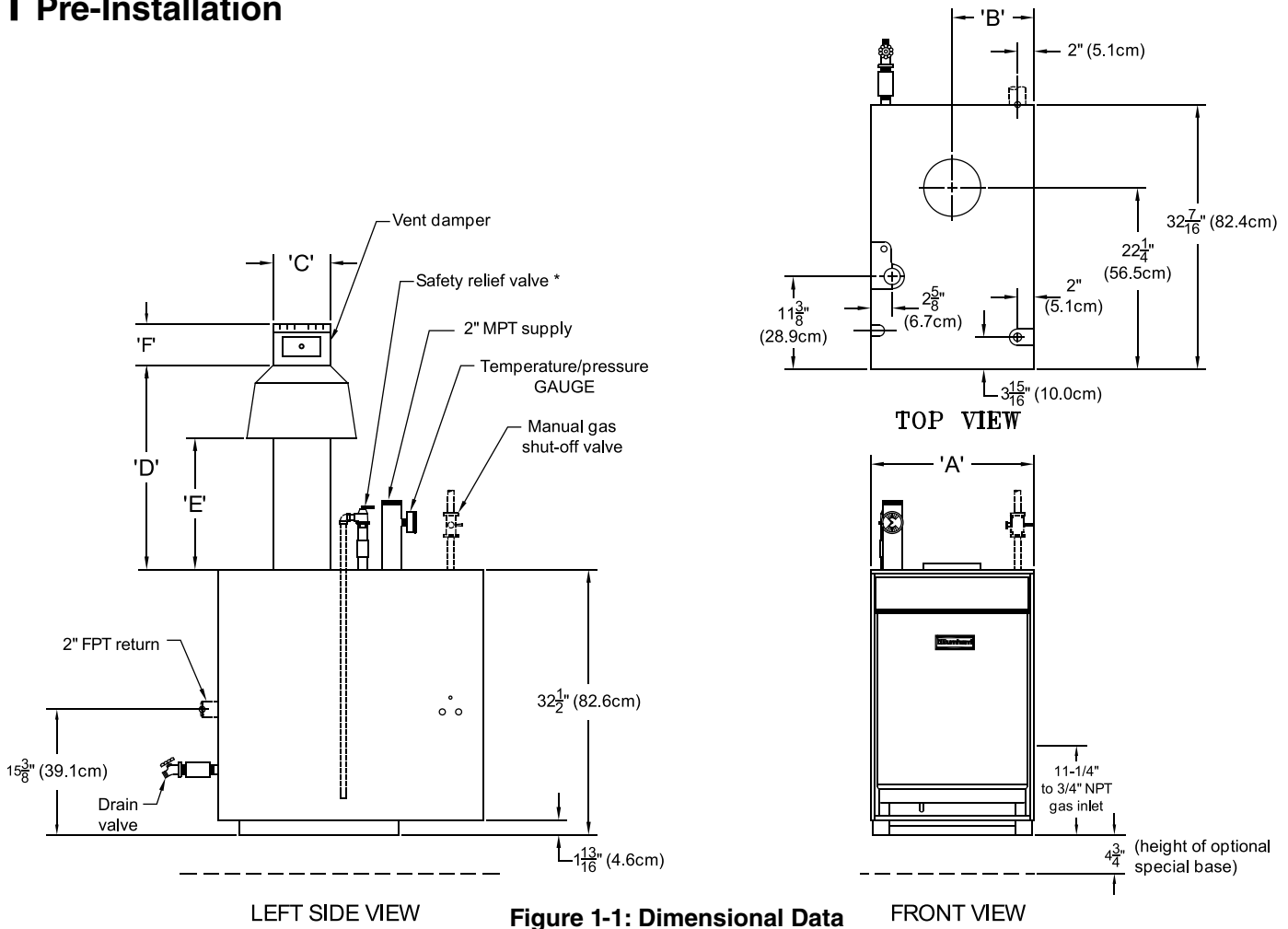

Figure 1-1: Dimensional Data

Table 1-2: Dimensional Data

BOILER MODEL	INPUT (MBH)	DIMENSIONS (INCHES)						WATER CONTENT (GALLONS)	APPROX. SHIPPING WEIGHT (LB)	
		'A'	'B'	'C'	'D'	'E'	'F'		PACKAGED	KNOCKDOWN
805HE	239	20	10	7	21-1/2	11-5/8	6	11.9	600	610
806HE	299	23-3/4	11-7/8	8	27-13/16	18	7-1/8	13.9	690	700

* Maximum allowable working pressure: 50 psi (water only)

1 Pre-Installation *(continued)*

WARNING

Carefully read all instructions before installing boiler. Failure to follow all instructions in proper order can cause personal injury or death.

- A. Inspect shipment carefully for any signs of damage. All equipment is carefully manufactured, inspected and packed. Our responsibility ceases upon delivery of boiler to carrier in good condition. Any claim for damage or shortage in shipment must be filed immediately against carrier by consignee. No claims for variances or shortages will be allowed by Boiler Manufacturer, unless presented within sixty (60) days after receipt of equipment.
- B. Installation must conform to the requirements of the authority having jurisdiction. In the absence of such requirements, installation must conform to the *National Fuel Gas Code*, NFPA 54/ANSI Z223.1. Where required by the authority having jurisdiction, the installation must conform to the *Standard for Controls and Safety Devices for Automatically Fired Boilers*, ANSI/ASME No CSD-1.
- C. Boiler is certified for alcove installation with the following clearances from combustible construction:
 1. Front: 18 in.
 2. Top: 36 in.
 3. Draft hood, rear, sides and flue connector: 6 in.
- D. Provide clearance for servicing and proper operation (following clearances are recommended and may be reduced to minimum clearances shown above):
 1. Single boiler, Front/Top: 24 in. (61.0 cm)
 2. Multiple boiler, Sides: 1 in. (2.5 cm)

WARNING

Appliance is design certified for installation on noncombustible flooring only. For installation on combustible flooring only when installed on special base listed in Table 1-3. Boiler must not be installed on carpeting. When boiler is installed on concrete which is over a material that is subject to melting (PVC, PEX radiant tubing, etc.), the special base must be used. A concrete pad is not sufficient to protect combustible flooring.

Table 1-3: Special Base Required for Installation on Combustible Flooring

Boiler Model	Special Base Part Number
805HE	61816055
806HE	61816065

- E. Install boiler on level floor as close to chimney as possible. For basement installation provide a solid base such as concrete or masonry construction if floor is not level or if water may be encountered on floor around boiler.
- F. Protect gas ignition system components from water (dripping, spraying, rain, etc.) during boiler operation and service (circulator replacement, control replacement, etc.).
- G. Locate boiler to avoid water damage in case there is a leak. If boiler must be located in an area sensitive to water damage, install drain pan underneath boiler and pipe to a suitable drain location. Manufacturer will not be held responsible for water damage resulting from this appliance or any of its components.
- H. Provide combustion and ventilation air in accordance with applicable provisions of local building codes, or the *National Fuel Gas Code*, NFPA 54/ANSI Z223.1, Air for Combustion and Ventilation.
- I. If replacing an existing boiler, check for and correct common system problems including:
 1. System leaks resulting in premature heat exchanger failure from oxygen corrosion or hardness deposits
 2. Inadequate freeze protection resulting in system freezing and leaking
 3. Dirt or debris left in existing piping if it has not been properly flushed or cleaned

WARNING

- Adequate combustion and ventilation air must be provided to assure proper combustion.
- Do not install boiler where gasoline or other flammable vapors or liquids, or sources of hydrocarbons (i.e. bleaches, cleaners, chemicals, sprays, paint removers, fabric softeners, etc.) are used or stored.

NOTICE: Mis-sizing of the boiler with regard to the heating system load will result in excessive boiler cycling and accelerated component failure. Burnham Commercial DOES NOT warrant failures caused by mis-sized boiler applications. DO NOT oversize the boiler to the system.

1 Pre-Installation *(continued)*

- J. For Multiple boiler installations see also Series 8HE Multiple Boiler Application Instructions, 111924-01, available on Burnham Commercial website.
- K. Check for and remove any potential combustion air contaminants from area around boiler. See Table 1-4.

NOTICE: Flue side corrosion caused by contaminants is not covered by warranty.

Table 1-4: Corrosive Combustion Contaminants and Sources

Contaminants to avoid:
Spray cans containing chloro/fluorocarbons (CFC's)
Permanent wave solutions
Chlorinated waxes/cleaners
Chlorine-based swimming pool chemicals
Calcium chloride used for thawing
Sodium chloride used for water softening
Refrigerant leaks
Paint or varnish removers
Hydrochloric acid/muriatic acid
Cements and glues
Antistatic fabric softeners used in clothes dryers
Chlorine-type bleaches, detergents, and cleaning solvents found in household laundry rooms.
Adhesives used to fasten building products and other similar products
Excessive dust and dirt
Areas likely to have contaminants:
Dry cleaning/laundry areas and establishments
Swimming pools
Metal fabrication plants
Beauty shops
Refrigeration repair shops
Photo processing plants
Auto body shops
Plastic manufacturing plants
Furniture refinishing areas and establishments
New building construction
Remodeling areas
Garages with workshops

2 Boiler Assembly

⚠ WARNING

Use precautions and appropriate rigging apparatus when moving heavy objects.

- A. Remove Crate
1. Remove all fasteners at crate skid.
 2. Lift outside container and remove with all other inside protective spacers and bracing.
- B. Remove boiler from skid. See Figure 2-1. Exercise care to avoid dropping boiler.
1. Place boiler in approximate location. Refer to Section 1: Pre-Installation. Remove base hold down bolts.
 2. Using pry bar under rear corner of Base End Panel, raise boiler and install 1½ in. wood blocks under rear corners. Install ¾ in. pipe roller between Base and skid.
 3. Remove 1½ in. wood blocks. Place 3 in. pipe roller on floor behind skid.
 4. Roll boiler off skid. Move skid out of way.
 5. Roll boiler until 3 in. roller is located as shown. Use pry bar to install wood blocks under front corners of base. Remove 3 in. roller.
 6. Lift boiler with pry bar. Remove wood blocks. Lower boiler.
- C. For Packaged Boiler only, proceed to Paragraph E.
- D. Test Section Assembly for leaks before connecting to system and installing controls, trim and jacket. See Figure 2-3 and Table 2-2.
1. Attach pressure gauge capable of indicating 50 psi. Boiler Temperature-Pressure gauge may be used and is located in Water Trim Carton.
For testing gauge may be connected to permanent location in 2 in. NPT supply pipe as shown in Figures 3-4 and 3-5 or may be connected to a tapping that is unused for pressure testing, such as in Tapping C shown in Figure 2-3.
 2. Install purge valve with a hose that runs to a drain in supply tapping or supply pipe.
 3. Install fill valve and piping to Drain Tapping G.
 4. Plug remaining open tappings.
 5. Fill boiler completely with water by venting air through purge valve. Close purge valve and apply water pressure of at least 10 psi but less than 50 psi gauge pressure.

6. Examine boiler for leaks or damage due to shipment or handling.
7. Remove fill valve, purge valve and piping.

⚠ WARNING

Do not use air to leak test boiler.

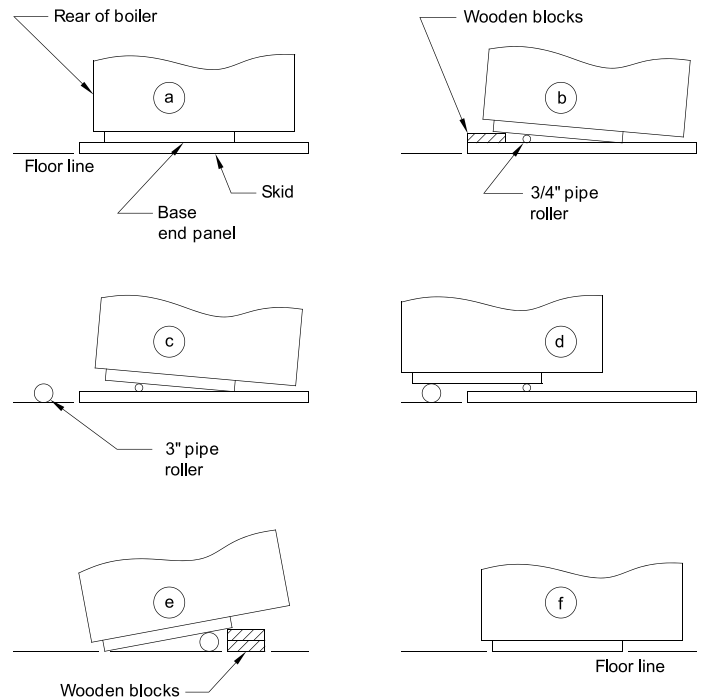

Figure 2-1: Skid Removal

- E. Install special base if installation is on combustible flooring. See Figure 2-4. Floor shield adds 4¾ in. to boiler height.
1. Place special base on combustible floor with surface marked "FRONT" in upward position.
 2. Locate special base with spacing to combustible materials as shown in Figure 2-4.
 3. Place boiler on special base. Boiler must rest inside locating brackets. Boiler jacket panels will overhang special base.
 4. Do not enclose boiler (including special base) on all four sides.
- F. Move boiler to permanent location by sliding or walking. Do not drop.

For Packaged Boiler, proceed to Paragraph L.

⚠ CAUTION

Sheet metal parts may have sharp edges or burrs, use proper Personal Protective Equipment (PPE) during assembly.

2 Boiler Assembly *(continued)*

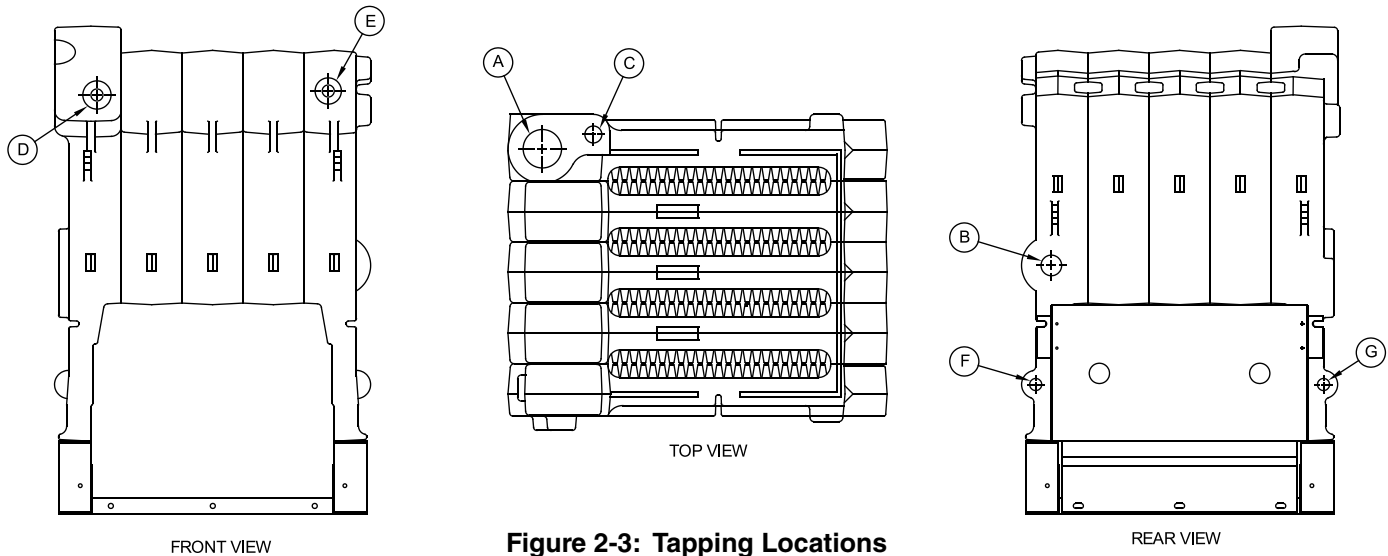

Figure 2-3: Tapping Locations

Table 2-2: Purpose of Tappings

Tapping	Size	Purpose
A	2 in.	Supply
B	2 in.	Return
C	3/4 in.	Relief Valve
D	3/4 in.	HydroStat ® Limit
E	3/4 in.	Opt. Auxiliary L4006E Limit
F	3/4 in.	Washout
G	3/4 in.	Drain

- G. Confirm that one (1) Flue Baffle is properly positioned in each Boiler Flueway. Tabs at the top of each Flue Baffle should be resting on top row of Flue Pins on each adjoining section.
- H. Install Canopy on section assembly. See Figure 2-5. Canopy and hardware are located in Combination Boiler Parts and Control Carton.
1. Place ceramic fiber blanket on top of block assembly perimeter.
 2. Position Canopy on top of Section Assembly. Locate between end sections and sealing ledge on front and back of each section.
 3. Fasten each end with 1/4 in. - 20 x 1 in. carriage bolts, washers and nuts.
- I. Inspect joints between sections. They were factory sealed. If any openings resulted during shipment or handling, reseal with furnace cement. Confirm tie rods are only hand tight to allow for thermal expansion.

- J. Install Base Front Panel. See Figure 2-5. Panel and hardware located in Combination Boiler Parts and Control Carton.
1. Attach Base Front Panel to Section Assembly using 1/4 in. - 20 x 1 1/4 in. carriage bolts, washers and nuts.
 2. Seal between top of Base Front Panel and Section Assembly with furnace cement (shipped in Combination Boiler Parts and Control Carton).
 3. Seal between top of Base Rear Panel and Section Assembly with furnace cement.

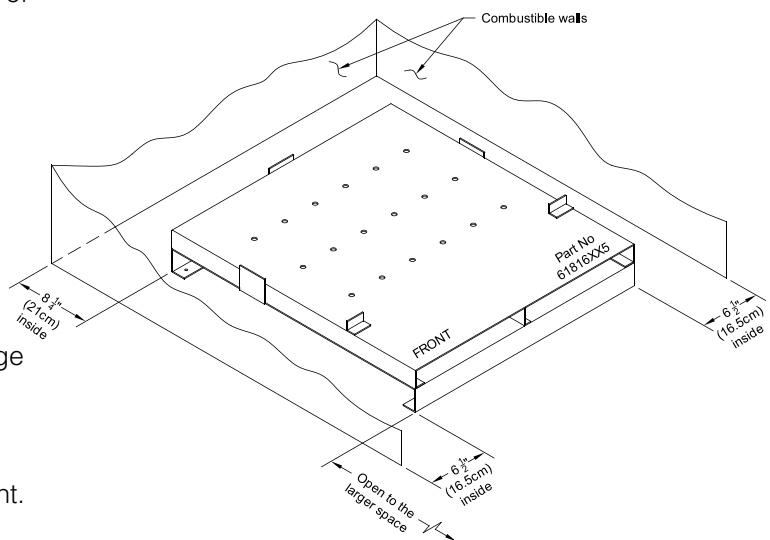

Figure 2-4: Installation of Special Base for Combustible Flooring

2 Boiler Assembly *(continued)*

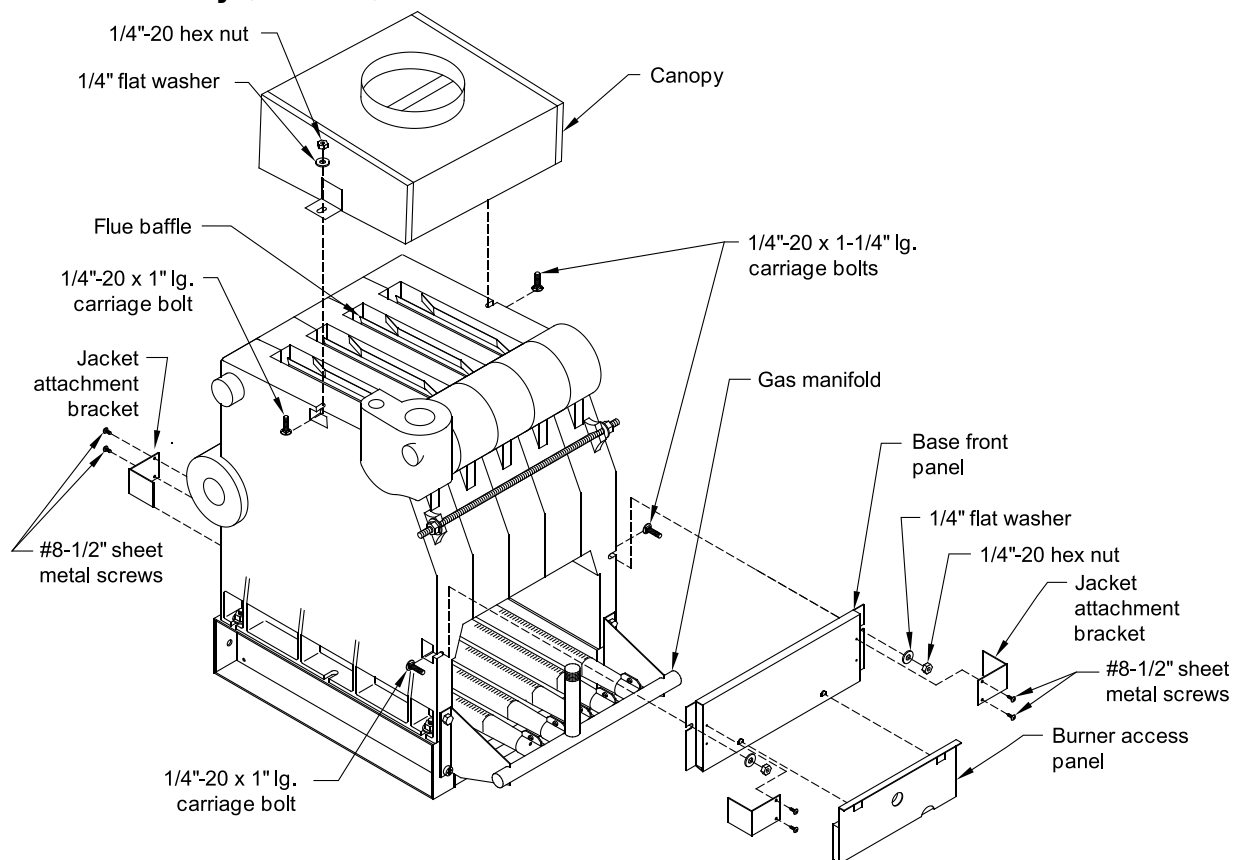

Figure 2-5: General Assembly (Knockdown Boilers)

- K. Install Pilot/Main Burner Assembly. See Figure 2-7. Assembly is located in Combination Boiler Parts and Control Carton. Verify assembly is properly located on support bracket in Base Rear Panel, seated on Main Burner Orifice, and secured with hitch pin clip.
- L. Burner Air Shutters. See Figure 2-7. (On Packaged Boilers, Front Door and Burner Access Panel(s) must be removed to make adjustments.) Initial setting of burner air shutters should be between fully open and approximately 11/16 in. between front edge of Burner Air Shutter and burner mounting ring should be approximately 11/16 in. To adjust this distance, loosen screw at top of air shutter and slide into correct position. Then tighten screw. (Replace Burner Access Panel(s) and Front Door on Packaged Boilers.)
For Packaged Boiler, proceed to Section 3: Water Trim and Piping.
- M. Attach Flame Roll-out Switch to Burner Access Panel. See Figure 2-6. Flame Roll-out Switch and hardware are located in Combination Boiler Parts and Control Carton. Flame Roll-out Switch is a single use device - do not test with heat - switch cannot be reset.
1. Cut insulation from semicircular notch at right end of the burner access panel.
 2. Attach Flame Roll-out Switch Mounting Bracket to burner access panel with (1) #8 x 1/2 in. lg. sheet metal screw.
 3. Attach Flame Roll-out Switch to mounting bracket with (1) #8 x 3/4 in. lg. sheet metal screw.
- N. Install Burner Access Panel(s). Locate Burner Access Panel(s) in Combination Boiler Parts and Control Carton. Engage Burner Access Panel holes with projections on Base Front Panel. See Figure 5.
- O. Install Electro-Well and Immersion Well.
1. Remove 3/4 NPT x 1 in. Electro-Well (black plastic) from Combination Boiler Parts and Control Carton.
 2. Insert Electro-Well in Tapping D. See Figure 2-3.
 3. Insert 3/4 NPT x 3 in. Immersion-Well (brass) in Tapping E. If vertical gas piping is to be installed inside of boiler jacket, it is recommended that second limit be installed in system piping.

2 Boiler Assembly *(continued)*

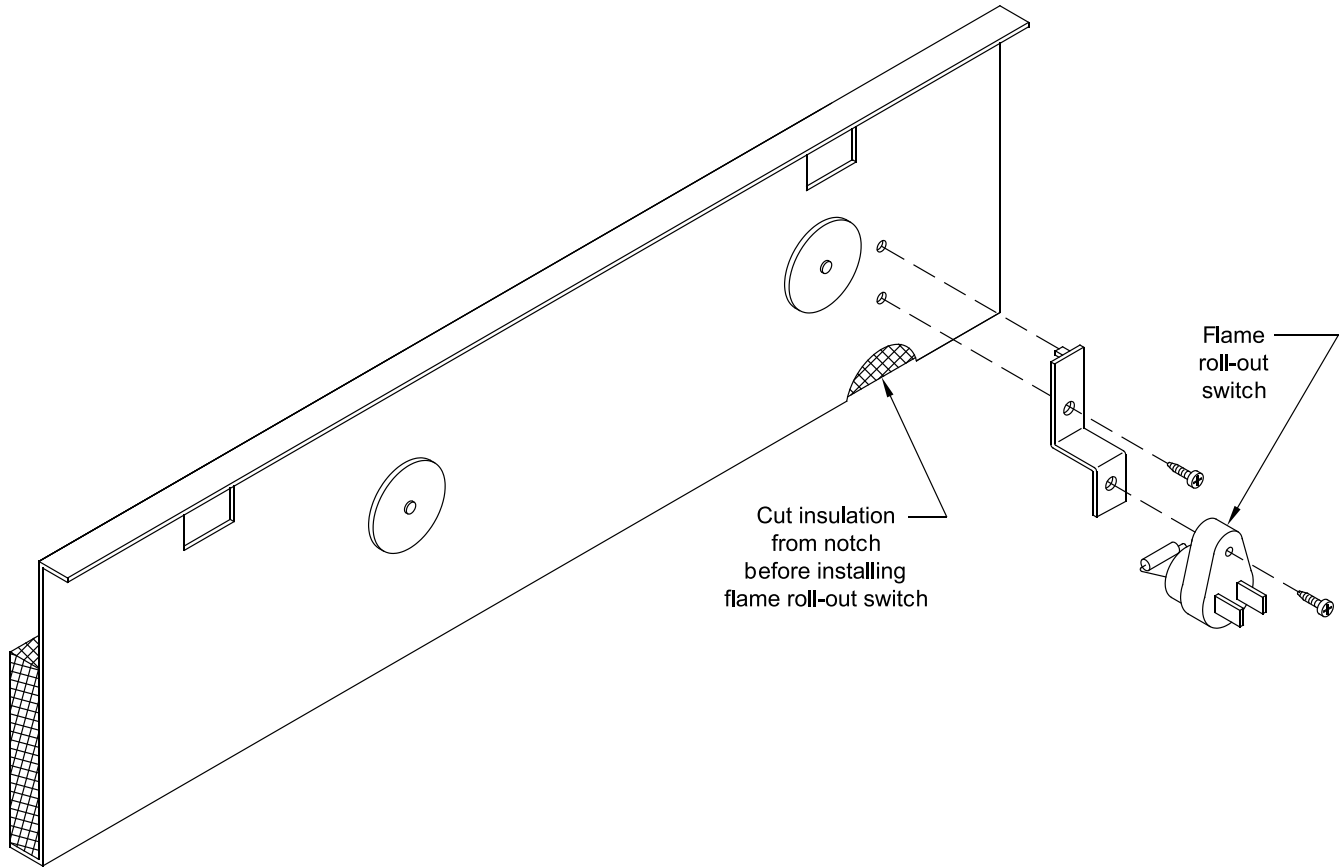

Figure 2-6: Flame Roll-out Switch Installation

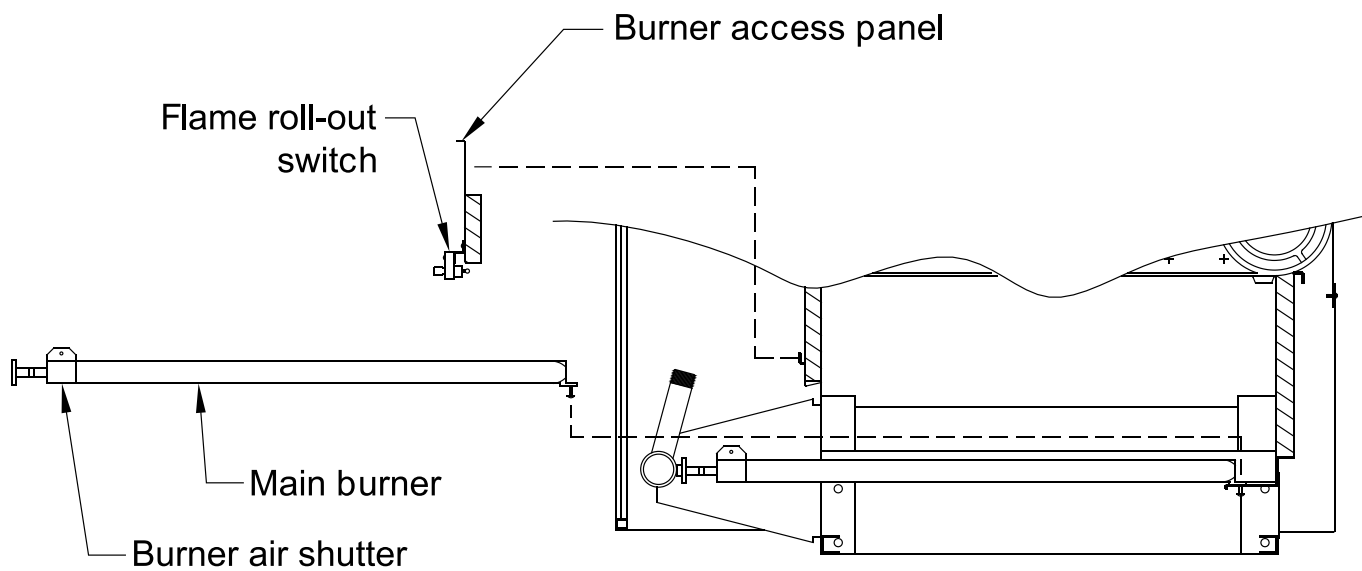

Figure 2-7: Burner/Burner Access Panel Installation

2 Boiler Assembly *(continued)*

P. Install Jacket. See Figure 2-9.

1. Locate four (4) Jacket Attachment Brackets in Combination Boiler Parts and Control Carton. Attach to Front Base Panel and Rear Base Panels with #8 sheet metal screws. See Figure 2-5.
2. Hang Left Side Panel and Right Side Panel onto Jacket Attachment Brackets.
3. Attach Lower Rear Panel to Left and Right Side Panels. Do not tighten sheet metal screws.
4. Attach Upper Rear Panel to Lower Rear Panel. Do not install three (3) upper screws.
5. Remove Rating Label from envelope marked "RATING LABEL ENCLOSED". Remove Combustible Clearance Label from Combination Boiler Parts and Controls Carton. Attach to Vestibule Panel in locations shown.
6. Attach Vestibule Panel to Left Side and Right Side Panels.
7. Attach Lower Front Tie Bar to Left Side and Right Side Panels.
8. Engage Upper Front Panel in slots on Left Side and Right Side Panels. Place Top Panel in position. Attach Top Panel to Left Side, Right Side and Upper Rear Panels.
9. Tighten all jacket screws.
10. Affix Lighting/Operating Instructions Label and Wiring Diagram Label to inside of Front Removable Door. Labels are located in Combination Boiler Parts and Control Carton.

Q. Install Hydrostat 3200 Limit Control.

Locate limit in Combination Boiler Parts and Control Carton, as well as the Hydrostat Remote Mounting Brackets. See Figure 2-8 for location of screw holes on Jacket Vestibule Panel for remote mounting brackets.

1. Attach bottom mounting bracket to Vestibule Panel with two (2) standard truss head jacket screws.
2. Insert the top mounting bracket into the slots on the back of the limit control and rotate the bracket upward.
3. Place the limit control box on to the bottom mounting bracket and attach the top bracket with two (2) more standard truss head jacket screws.
4. Insert limit probe into left immersion well as far as possible and secure with spring clip. (See also HydroStat 3200 manual provided with boiler).

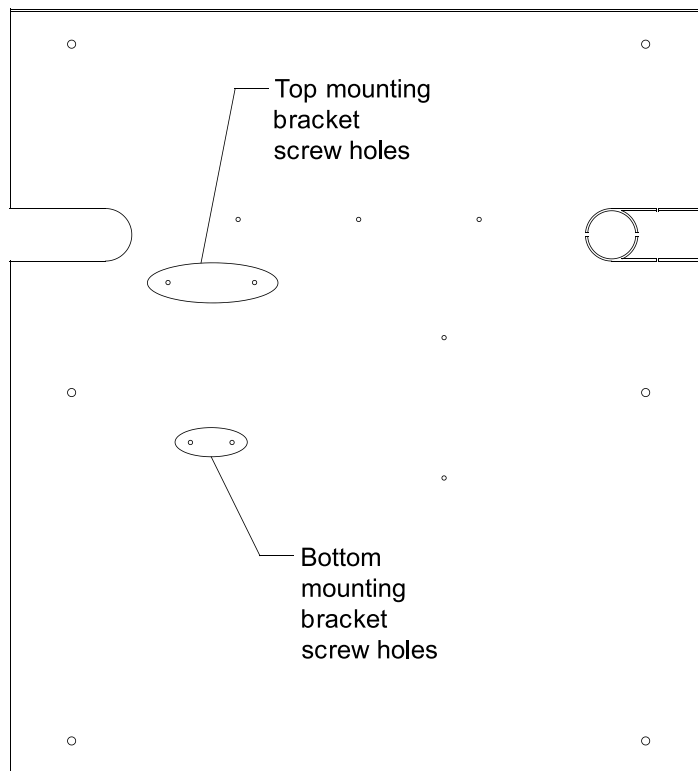

Figure 2-8: Hydrostat 3200 Remote Mounting Screw Holes on Jacket Vestibule Panel

- R. Install Auxiliary Limit or operating control (if used). Insert control probe into right immersion well as far as possible. Tighten screws.
- S. Install Gas Control System. All components are located in Combination Boiler Parts and Control Carton.
 1. Install Gas Control Assembly on Manifold. See Figure 2-10. Use thread (joint) compound (pipe dope) resistant to action of liquefied petroleum gas.
 2. Install pilot burner piping and controls. See Figure 2-11.
- T. Install Ignition Module.
 1. Attach Ignition Control Mounting Bracket to Jacket Vestibule Panel using two (2) #8 x 1/2 in. sheet metal screws.
 2. Attach Honeywell Ignition Module to Mounting Bracket using two (2) #8 x 1/2 in. sheet metal screws.
 3. Connect pilot ground wire and ignitor/sensor lead(s) to ignition module. Refer to "Section 6: Electrical" for connection details.

2 Boiler Assembly *(continued)*

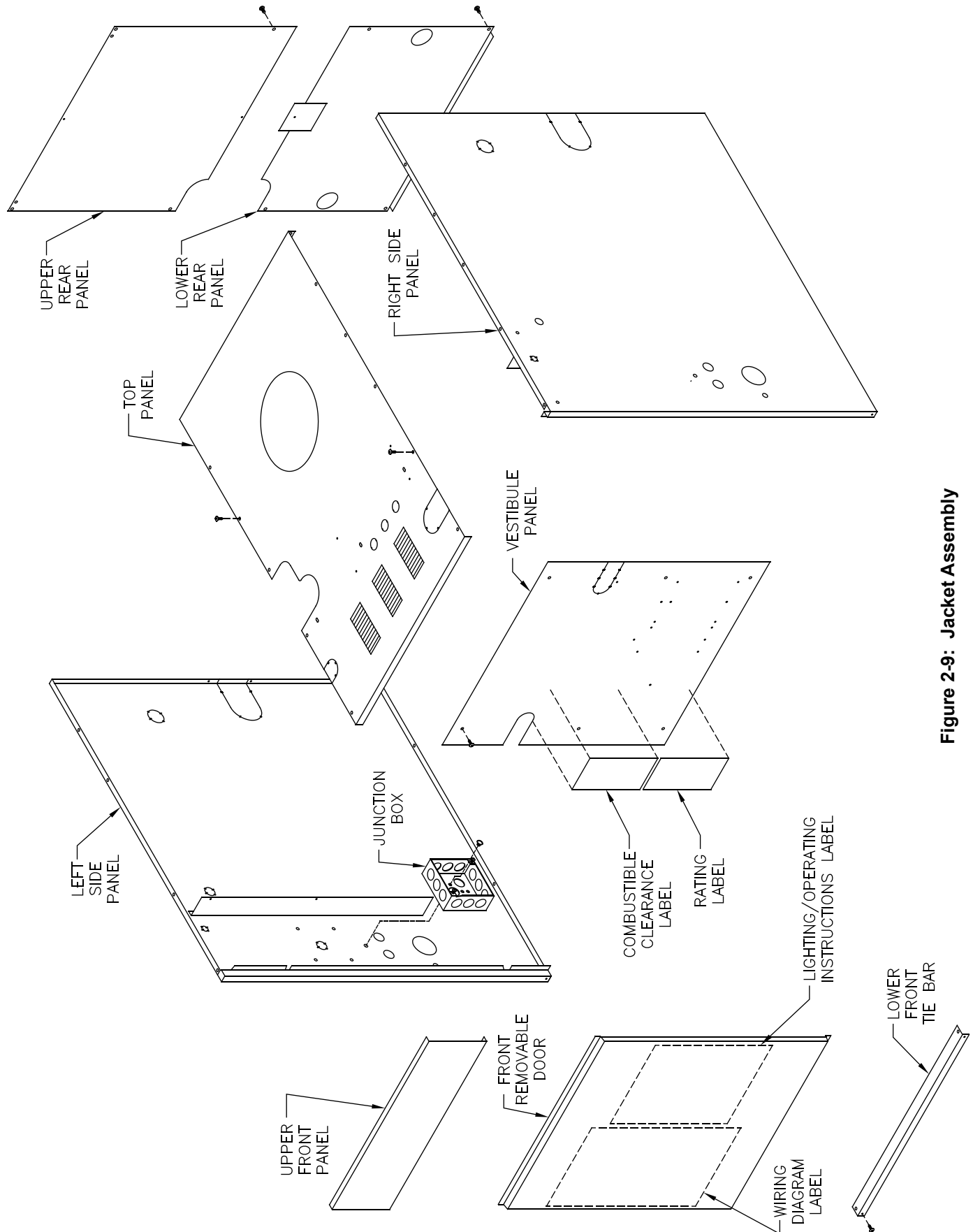

Figure 2-9: Jacket Assembly

2 Boiler Assembly *(continued)*

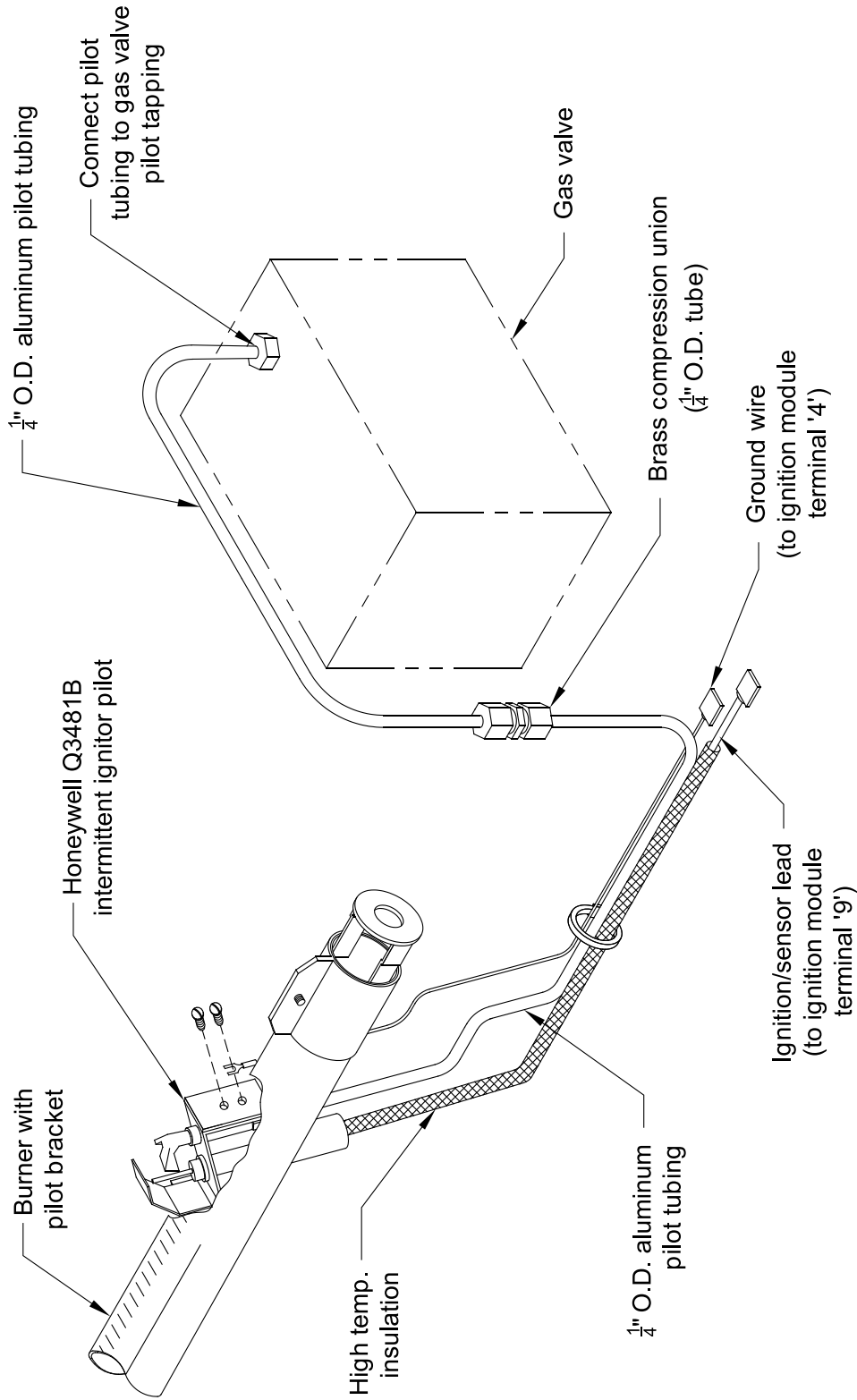

Figure 2-11: Schematic Pilot Piping

3 Water Trim and Piping

WARNING

- Failure to properly pipe boiler may result in improper operation and damage to boiler or structure.
 - Oxygen contamination of boiler water will cause corrosion of iron and steel boiler components, and can lead to boiler failure. Burnham Commercial's Warranty does not cover problems caused by oxygen contamination of boiler water or scale (lime) build-up caused by frequent addition of water.
- A. Design and install boiler and system piping to prevent oxygen contamination of boiler water and frequent water additions.
1. There are many possible causes of oxygen contamination such as:
 - a. Addition of excessive make-up water as a result of system leaks.
 - b. Absorption through open tanks and fittings.
 - c. Oxygen permeable materials in the distribution system.
 2. In order to insure long product life, oxygen sources must be eliminated. This can be accomplished by taking the following measures:
 - a. Repairing system leaks to eliminate the need for addition of make-up water.
 - b. Eliminating open tanks from the system.
 - c. Eliminating and/or repairing fittings which allow oxygen absorption.
 - d. Use of non-permeable materials in the distribution system.
 - e. Isolating the boiler from the system water by installing a heat exchanger.
 - f. Use properly designed and operating air elimination devices in water piping.
- B. Design boiler piping and flow rate to obtain proper temperature rise through the boiler. (See Table 3-1)
- C. Install Safety Relief Valve. See Figure 3-2. Components are located in Water Trim Carton. Safety Relief Valve must be installed with spindle in vertical position.
1. Install $\frac{3}{4}$ in. NPT x $3\frac{1}{2}$ in. lg. nipple in tapping "C". See Figure 2-3.
 2. Install safety relief valve on $\frac{3}{4}$ in. NPT nipple.

WARNING

- Pipe discharge of relief valve to a location where water or steam will not create a hazard or cause property damage if the relief valve opens.
- End of discharge pipe must terminate in an unthreaded pipe.
- If relief valve discharge is not piped to a drain, it must terminate at least 6 inches above floor.
- Termination of the relief valve discharge piping must be in an area where it is not likely to become plugged by debris or subjected to freezing.

DANGER

- Do not install any valves between boiler and relief valve.
- Do not install any valves between relief valve and discharge.
- Do not move relief valve from factory location.
- Do not plug relief valve discharge.
- Do not install a relief valve with a setting greater than 15 psi.

Table 3-1: Flow Rate, Temperature Rise, and Pressure Drop

Boiler Model	Flow Rate (GPM)	Temp. Rise Thru Boiler	Min. Boiler Piping NPT	Boiler Pressure Drop
805HE	20	20° F	1½ in.	3 ft.
	13	30° F	1¼ in.	2 ft.
	10	40° F	1¼ in.	1 ft.
806HE	25	20° F	1½ in.	3 ft.
	17	30° F	1½ in.	2 ft.
	13	40° F	1¼ in.	1 ft.

3 Water Trim and Piping *(continued)*

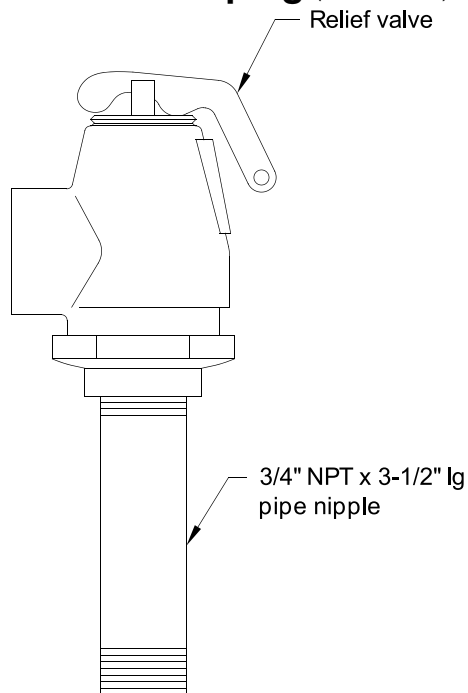

Figure 3-2: Safety Relief Valve Installation

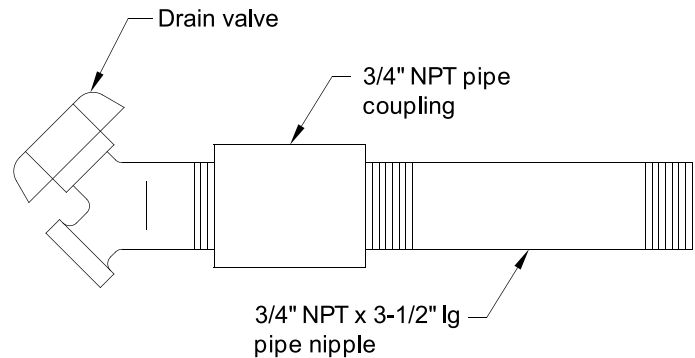

Figure 3-3: Drain Piping Installation

⚠ WARNING

- Burnham Commercial recommends maintaining temperature differential (drop) across the system at 40°F or less and return water temperature at minimum of 135°F.
- Continued boiler operation for prolonged periods of time under conditions when temperature differential across the system exceeds 40°F and/or return water temperature stays below 135°F, may result in premature boiler failure due to flue gas condensation and/or thermal shock.

- D. Install Drain Valve in rear of Left End Section, Tapping "G". See Figure 3-3. Components are located in Water Trim Carton.
- E. Install Temperature-Pressure Gauge. Components are located in Water Trim Carton.
- Standard Temperature - Pressure Gauge Piping. See Figure 3-4.
 - Install 2 in. NPT x 10 in. lg. nipple with gauge tapping into Supply Tapping "A". See Figure 2-3. Gauge tapping should face forward.
 - Insert Temperature-Pressure Gauge. Tighten by applying pressure to square shank on back of gauge. **DO NOT APPLY PRESSURE ON GAUGE CASE** since this may ruin gauge calibration.
 - Alternate Temperature-Pressure Gauge Piping. See Figure 3-5.
 - Install 2 NPT x 10 in. Nipple into Supply Tapping "A". See Figure 2-3.
 - Install 2 NPT x 3/4 NPT x 2 NPT Tee (provided) or 2 NPT x 2 NPT x 3/4 NPT Tee (installer furnished). 3/4 NPT leg should face forward.
 - Install 3/4 NPT x 1/4 NPT Bushing.
 - Insert Temperature-Pressure Gauge. Tighten by applying pressure to square shank on back of gauge. **DO NOT APPLY PRESSURE ON GAUGE CASE** since this may ruin gauge calibration.
- F. Connect system supply and return piping to boiler.
- Maintain minimum 1/2 in. clearance from hot water piping to combustible materials.
 - Pump flow rates and minimum boiler supply and return pipe sizes are shown in Table 3-1.
 - If boiler is used in connection with refrigeration systems, boiler must be installed with chilled medium piped in parallel with heating boiler using appropriate valves to prevent chilled medium from entering boiler. See Figure 3-6.
 - If boiler is connected to heating coils located in air handling units where they may be exposed to refrigerated air, boiler piping must be equipped with flow control valves to prevent gravity circulation of boiler water during cooling system operation. A hot water boiler installed above radiation level must be provided with a low water cutoff device as part of installation. The HydroStat control provided with the boiler includes a low water cut-off function.
 - Continued boiler operation for prolonged periods of time under conditions when temperature differential across the system exceeds 40°F and/or return water temperature stays below 135°F, may result in premature boiler failure due to flue gas condensation and/or thermal shock.

3 Water Trim and Piping *(continued)*

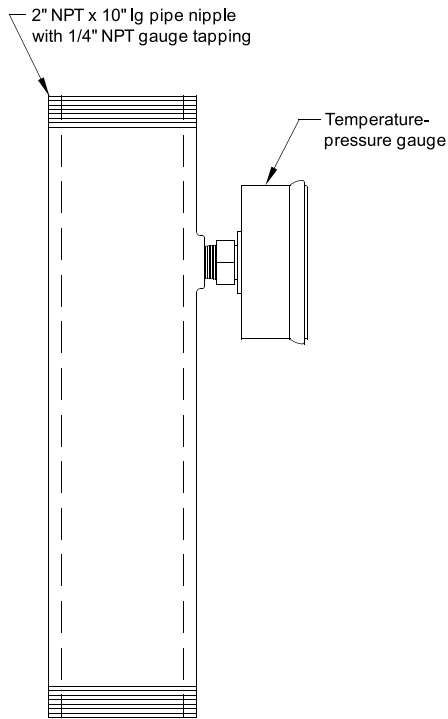

Figure 3-4: Temperature-Pressure Gauge Installation

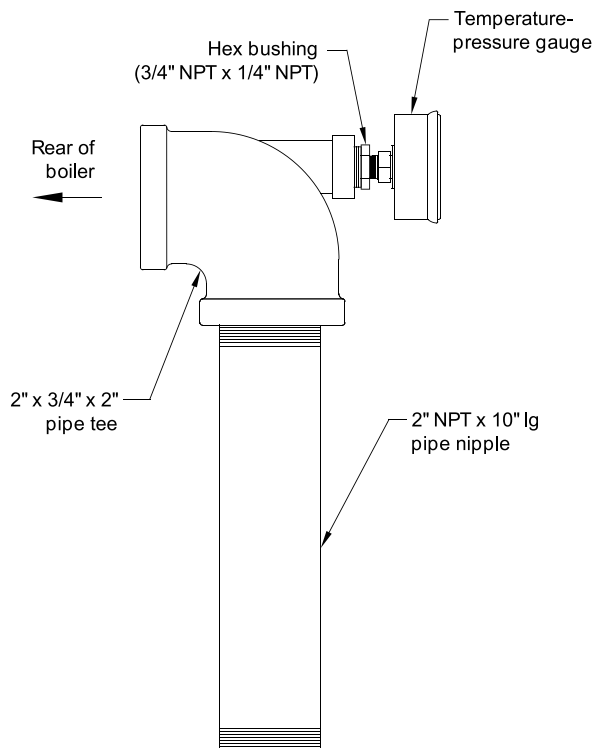

Figure 3-5: Alternate Temperature-Pressure Gauge Installation

Methods to provide boiler water protection are listed below. See also Tekmar Essay #021 "Mixing Methods and Sizing of Variable Speed Injection Pumps", Taco #102-143 Variable Speed Circulator Instruction Sheet, and information from mixing valve manufacturer.

- a. Bypass Piping – Bypass piping is recommended for any installation for improved system temperature balance, while serving to protect the boiler from sustained condensing operation. The bypass also provides some measure of low return water temperature protection by reducing flow through the boiler. See upper part of Figure 3-7.
- b. Bypass Circulator - A bypass circulator is recommended to divert hot supply water into the return when system return temperatures can periodically dip below 135°F. A variable speed circulator is recommended for increased protection. See Figure 3-7 Detail A.
- c. Primary/secondary Piping with Bypass – Primary/Secondary piping is recommended to provide two points of mixing when dual temperature systems are used (i.e. baseboard and radiant heat, outdoor reset and domestic hot water production, systems incorporating night setback or multiple zone pumps on clock schedules). See Figure 3-7, Detail B.
- d. Primary/secondary Piping with 3-way Valve – A 3-way valve with return temperature sensor is recommended to protect the boiler or sensing element from sustained condensing operation, particularly if the system will continuously run below 135°F for extended periods (due to low temperature applications like snow melt, heat pump systems or others). See Figure 3-7, Detail C, and information from mixing valve vendor.

3 Water Trim and Piping *(continued)*

6. A hot water boiler installed above radiation level must be provided with a low water cutoff device as part of installation. The HydroStat control provided with the boiler includes a low water cutoff function.
 7. A start-up strainer is recommended for all installations (new and replacement alike) to prevent system debris and sediment from ending up in the boilers where it will inhibit heat transfer and may eventually cause a cast iron section to crack from overheating.
- G. Indirect Water Heater (if used). Refer to Indirect Installation, Operating and Service Instructions for additional information. Install in same manner as space heating zone.

Water Quality Requirements

pH: 6.0 - 9.5

Total hardness grains / gal: < 7

Chlorides: < 50 ppm

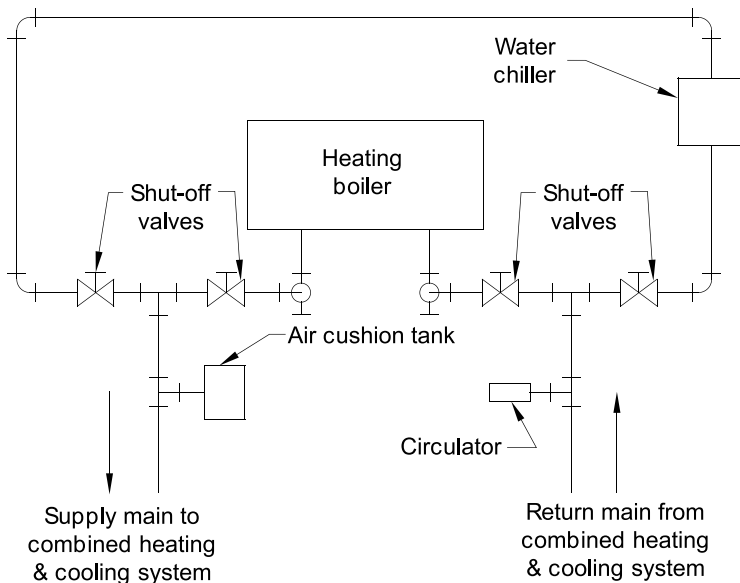
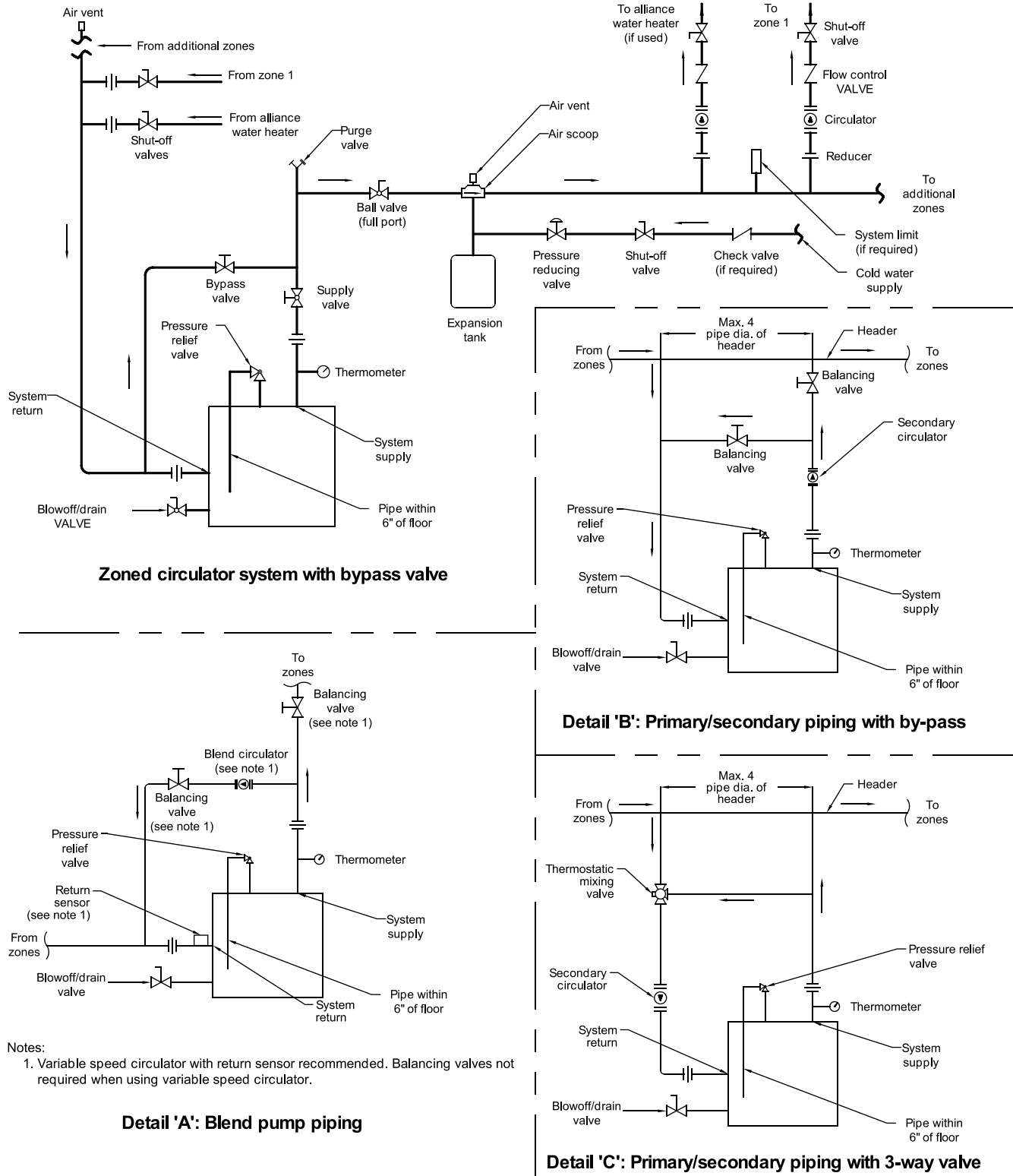

Figure 3-6: Recommended Piping for Combination Heating & Cooling (Refrigeration) System

3 Water Trim and Piping (continued)



Notes:
 1. Variable speed circulator with return sensor recommended. Balancing valves not required when using variable speed circulator.

Figure 3-7: Boiler Piping

4 Gas Piping

WARNING

Failure to properly pipe gas supply to boiler may result in improper operation and damage to the boiler or structure. Always assure gas piping is absolutely leak free and of the proper size and type for the connected load.

An additional gas pressure regulator may be needed. Consult gas supplier.

- A. Size gas Piping. Design system to provide adequate gas supply to boiler. Consider these factors:
1. Allowable pressure drop from point of delivery to boiler. Maximum allowable system pressure is ½ psig. Actual point of delivery pressure may be less; contact gas supplier for additional information. Minimum allowable gas valve inlet pressure is indicated on rating label.
 2. Maximum gas demand. Table 4-1 lists boiler input rate. Also consider existing and expected future gas utilization equipment (i.e. water heater, cooking equipment).
 3. Length of piping and number of fittings. Refer to Table 4-2 for maximum capacity of Schedule 40 pipe. Table 4-3 lists equivalent length for standard fittings.

Table 4-1: Rated Input

Boiler Model	Rated Capacity (cubic feet per hour, Natural Gas)	Gas Connection Size
805HE	239	3/4 in.
806HE	299	3/4 in.

WARNING

- Failure to use proper thread compounds on all gas connectors may result in leaks of flammable gas.
- Gas supply to boiler and system must be shut off prior to installing or servicing boiler gas piping

NOTICE: Boilers built for installation at altitudes from 2,001 feet - 5,000 feet above sea level have been specially orificed to reduce gas input rate 4 percent per 1,000 feet above sea level per the National Fuel Gas Code, NFPA 54/ANSI Z223.1.

- B. Connect boiler gas valve to gas supply system.
1. Use methods and materials in accordance with local plumbing codes and requirements of gas supplier. In absence of such requirements, follow the *National Fuel Gas Code*, NFPA 54/ANSI Z223.1.
 2. Use thread (joint) compound (pipe dope) resistant to action of liquefied petroleum gas.
 3. Install sediment trap, ground-joint union and manual shut-off valve upstream of boiler gas valve and outside jacket. See Figure 4-5.
 4. All above ground gas piping upstream from manual gas valve must be electrically continuous and bonded to a grounding electrode. Do not use gas piping as a grounding electrode. Refer to the *National Electrical Code*, NFPA 70.

DANGER

Explosion Hazard.

Do not use matches, candles, open flames, or other ignition sources to check for leaks. Failure to comply could result in severe personal injury, death or substantial property damage.

- C. Pressure Test. The boiler and its gas connection must be leak tested before placing boiler in operation. Follow National Fuel Gas Code, ANSI Z22.3.1/NFPA 54.

4 Gas Piping *(continued)*

Table 4-2: Maximum Capacity of Schedule 40 Pipe in CFH for Gas Pressures of 0.5 psig or Less

Length (Feet)	0.3 Inch w.c. Pressure Drop				0.5 Inch w.c. Pressure Drop			
	½	¾	1	1¼	½	¾	1	1¼
10	132	278	520	1,050	175	360	680	1,400
20	92	190	350	730	120	250	465	950
30	73	152	285	590	97	200	375	770
40	63	130	245	500	82	170	320	660
50	56	115	215	440	73	151	285	580
60	50	105	195	400	66	138	260	530
70	46	96	180	370	61	125	240	490
80	43	90	170	350	57	118	220	460
90	40	84	160	320	53	110	205	430
100	38	79	150	305	50	103	195	400

Table 4-3: Equivalent Lengths of Standard Pipe Fittings & Valves

Pipe Size	I.D. (Inches)	Valves (Fully Open)				Threaded Fittings			
		Gate	Globe	Angle	Swing Check	90° Elbow	45° Elbow	90° Tee, Flow Through Run	90° Tee, Flow Through Branch
½ in.	0.622	0.35	18.6	9.3	4.3	1.6	0.78	1.0	3.1
¾ in.	0.824	0.44	23.1	11.5	5.3	2.1	0.97	1.4	4.1
1 in.	1.049	0.56	29.4	14.7	6.8	2.6	1.23	1.8	5.3
1¼ in.	1.380	0.74	38.6	19.3	8.9	3.5	1.6	2.3	6.9

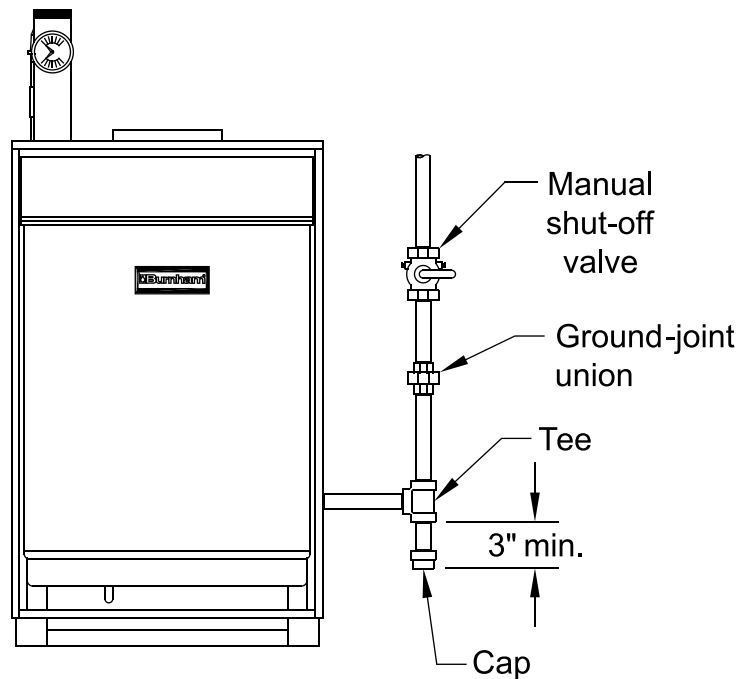

FRONT VIEW

Figure 4-4: Recommended Gas Piping

5 Venting

A. Install vent system in accordance with local building codes; or local authority having jurisdiction; or *National Fuel Gas Code*, ANSI Z223.1/NFPA 54. Install any of the following for this Category I, draft hood equipped appliance:

1. Type B or Type L gas vent. Install in accordance with listing and manufacturer's instructions.
2. Masonry or metal chimney. Build and install in accordance with local building codes; or local authority having jurisdiction; or *Standard for Chimneys, Fireplaces, Vents, and Solid Fuel Burning Appliances*, ANSI/NFPA 211.
Masonry chimney must be lined with approved clay flue lining or listed chimney lining system.
3. Single wall metal vent. Allowed by ANSI Z223.1/NFPA 54 under very restrictive conditions.

B. Avoiding Flue Gas Condensation

⚠ WARNING

- Vent systems must not experience signs of continuous wetness.
- Masonry chimneys, and in particular external masonry chimneys, are more susceptible to the formulation of condensate. If a masonry chimney experiences signs of continuous wetness, a listed metal liner must be installed or an alternate vent system must be used.
- All masonry chimneys must use either a clay tile liner or listed metal liner.
- Recommend use of listed metal chimney liner with external masonry chimneys.
- For external masonry chimneys that do not include a listed metal chimney liner, recommend double wall vent connectors. Use only double wall material on long runs.
- See also Section 3, Water Trim and Piping, for methods to avoid flue gas condensation from low return water temperatures.

C. Inspect chimney and remove any obstructions or restrictions. Clean chimney if previously used for solid or liquid fuel-burning appliances or fireplaces.

⚠ DANGER

Inspect existing chimney before installing boiler. Failure to clean or replace perforated pipe or tile lining will cause severe injury or death.

D. Install Draft Hood on canopy outlet. Maintain height from Jacket Top Panel to Draft Hood skirt as shown in Figure 1-1. DO NOT ALTER, CUT, OR MODIFY DRAFT HOOD.

⚠ WARNING

Do not alter boiler draft hood or place any obstruction or non-approved damper in the breeching or vent system. Flue gas spillage can occur. Unsafe boiler operation will occur.

E. Install Blocked Vent Switch. The Blocked Vent Switch Assembly consists of a strain relief bushing, power cord, and switch attached to mounting bracket. On Packaged boilers, the assembly is shipped attached to top of boiler. On Knocked Down boilers, the assembly is located in Combination Boiler Parts and Control Carton.

1. Uncoil power cord.
2. Position mounting bracket onto lower edge of Draft Hood skirt. Locate center tooth (with #10 sheet metal screw) on outside and other two teeth inside Draft Hood skirt. See Figure 5-1.
3. Slide mounting bracket tight against lower edge of Draft Hood skirt. Position #10 sheet metal screw above skirt's stiffening rib.

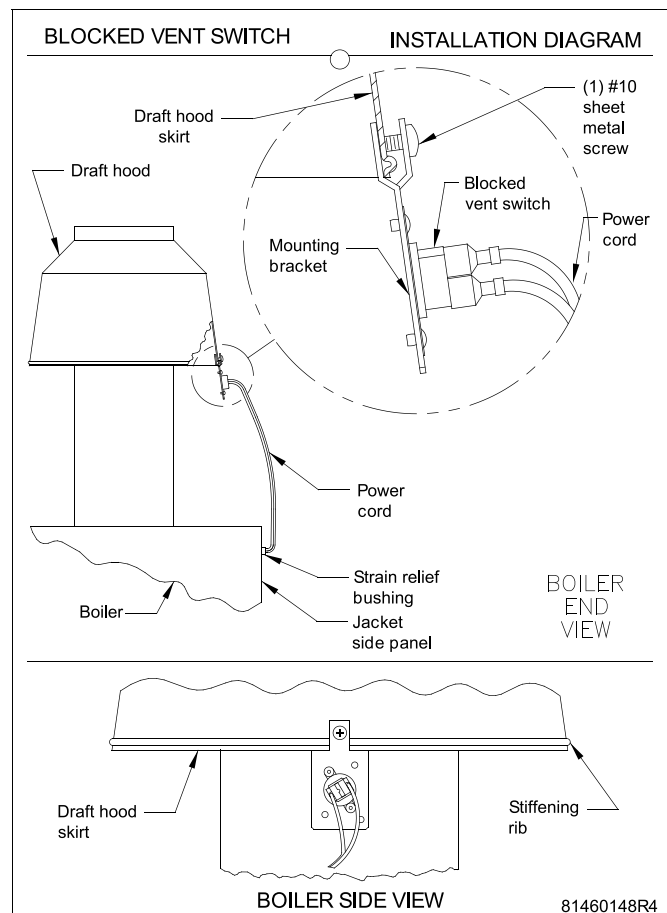

Figure 5-1: Blocked Vent Switch Installation

5 Venting *(continued)*

4. Secure bracket in position by tightening #10 sheet metal screw against outer surface of Draft Hood skirt.
5. Insert excess power cord through Jacket Right Side Panel hole. Remove slack.
6. Position strain relief bushing around power cord. Pinch bushing's two halves together and snap back into hole in Jacket Right Side Panel.
7. Verify power cord, mounting bracket, and Blocked Vent Switch are secure and located as shown in Figure 5-1.

WARNING

- Do not operate boiler without Blocked Vent Switch Properly installed.
- Do not use one vent damper to control two or more heating appliances.

F. Install Vent Damper. See Figure 5-2.

1. Open Vent Damper Carton and remove Installation Instructions. Read Installation Instructions thoroughly before proceeding.
2. Vent damper must be same size as draft hood outlet. See Figure 1-1. Unpack vent damper carefully. Forcing vent damper open or closed may damage gear train and void warranty. Vent damper assembly includes pre-wired connection harness with polarized plug.
3. Mount vent damper assembly on draft hood without modification to either (Refer to instructions packed with vent damper for specific instructions). Vent damper position indicator to be visible to users.

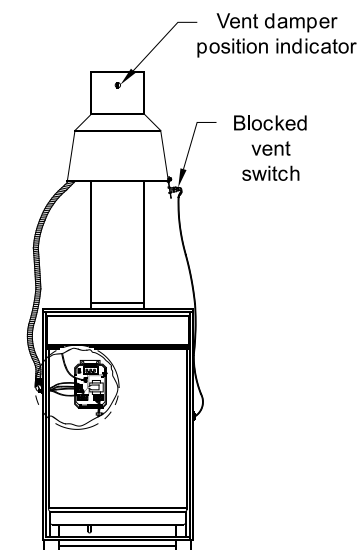
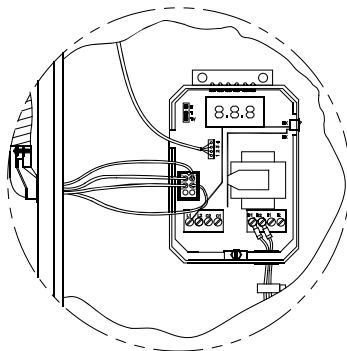
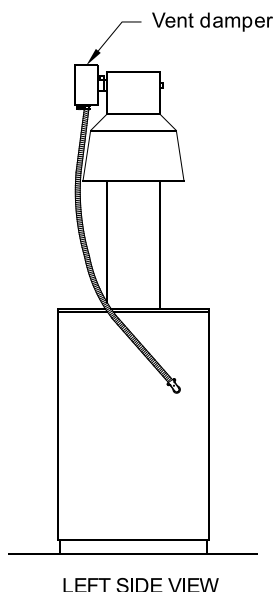

WARNING

Provide adequate clearance for servicing - provide 6 in. minimum clearance between damper and combustible construction.

G. Install Vent Connector from draft hood or vent damper to chimney. See Figure 5-3.

1. Do not connect into same leg of chimney serving an open fireplace.
2. Where two or more appliances vent into a common vent, the area of the common vent should at least equal the area of the largest vent plus 50 % of the area of the additional vents. Do not connect the vent of this appliance into any portion of mechanical draft system operating under positive pressure.
3. Vent connector should have the greatest possible initial rise above the draft hood consistent with the head room available and the required clearance from adjacent combustible building structure.
4. Install vent connector above bottom of chimney to prevent blockage - inspect chimney for obstructions or restrictions and remove - clean chimney if necessary.
5. Vent connector should slope upward from draft hood to chimney not less than one inch in four feet. No portion of vent connector should run downward or have dips or sags. Vent connector must be securely supported.
6. Use thimble where vent connector enters masonry chimney - keep vent connector flush with inside of flue liner.

Figure 5-2: Vent Damper Installation

5 Venting *(continued)*

7. Do not install Non-listed (AGA, CGA, CSA, ETL, or UL) vent damper or other obstruction in vent pipe.
8. Locate Boiler as close to Chimney as possible consistent with necessary clearances. See Section 1: Pre-Installation.
9. Design vent system for sea level input.
10. Provide adequate ventilation of Boiler Room. See Section 1: Pre-Installation.
11. Never pass any portion of vent system through a circulating air duct or plenum.

⚠ WARNING

When an existing boiler is removed from a common venting system, the common venting system is likely to be too large for proper venting of the appliances remaining connected to it.

H. If an Existing Boiler is Removed:

At the time of removal of an existing boiler, the following steps shall be followed with each appliance remaining connected to the common venting system placed in operation, while the other appliances remaining connected to the common venting system are not in operation:

1. Seal any unused openings in the common venting system.
2. Visually inspect the venting system for proper size and horizontal pitch and determine there is no blockage or restriction, leakage, corrosion, or other deficiencies which could cause an unsafe condition.
3. Insofar as is practical, close all building doors and windows and all doors between the space in which the appliances remaining connected to the common venting system are located and other spaces of the building. Turn on clothes dryers and any appliance not connected to the common venting system. Turn on any exhaust fans, such as range-hoods and bathroom exhausts, so they will operate at maximum speed. Do not operate a summer exhaust fan. Close fireplace dampers.
4. Place in operation the appliance being inspected. Follow the Lighting (or Operating) Instructions. Adjust thermostat so appliance will operate continuously.

5. Test for spillage at the draft hood relief opening after 5 minutes of main burner operation. Use the flame of a match or candle, or smoke from a cigarette, cigar or pipe.
6. After it has been determined that each appliance remaining connected to the common venting system properly vents when tested as outlined above, return doors, windows, exhaust fans, fireplace dampers and any other gas-burning appliance to their previous condition of use.
7. Any improper operation of the common venting system should be corrected so the installation conforms with the *National Fuel Gas Code*, NFPA 54/ANSI Z223.1. When resizing any portion of the common venting system, the common venting system should be resized to approach the minimum size as determined using the appropriate tables in the *National Fuel Gas Code*, NFPA 54/ANSI Z223.1.

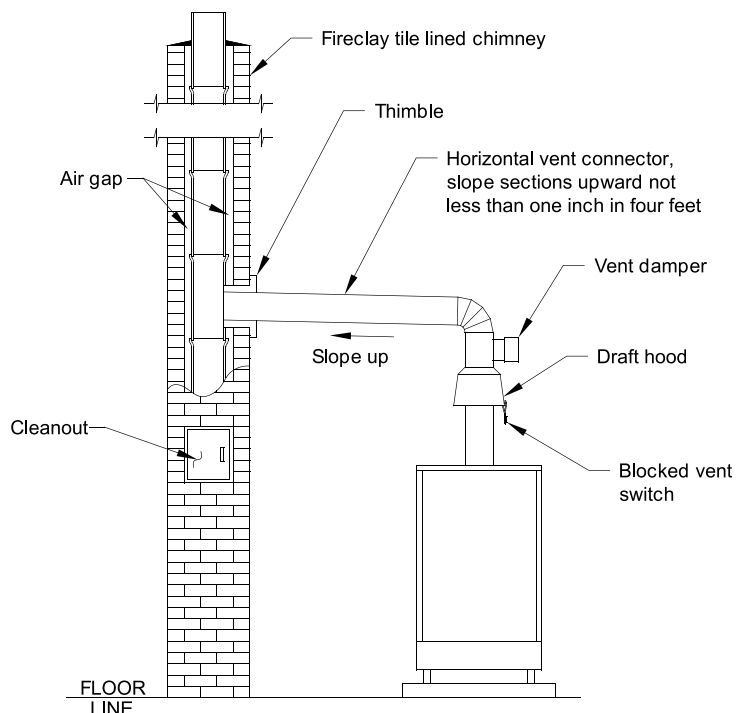

Figure 5-3: Typical Vent System

6 Electrical

DANGER

- Positively assure all electrical connections are unpowered before attempting installation or service of electrical components or connections of the boiler or building
- Lock out all electrical boxes with padlock once power is turned off.
- Electrical power may be from more than one source. Make sure all power is off before attempting any electrical work

WARNING

- Failure to properly wire electrical connections to the boiler may result in serious physical harm.
- Each boiler must be protected with a properly sized fused disconnect.
- Never jump out or make inoperative any safety or operating controls.
- The wiring diagrams contained in this manual are for reference purposes only. Each boiler is shipped with a wiring diagram attached to the front door. Refer to this diagram and the wiring diagram of any controls used with the boiler. Read, understand and follow all wiring instructions supplied with the controls.

A. Install Boiler Wiring

1. Knockdown boilers only. Locate wiring harnesses in Combination Boiler Parts and Control Carton. Refer to Figure 6-1 and connect wiring as shown.
2. Connect supply wiring and electrically ground boiler in accordance with requirements of authority having jurisdiction, or in absence of such requirements the *National Electrical Code*, NFPA 70.

B. Wire Vent Damper.

1. Attach Vent Damper Harness to mounting hole in Jacket Left Side Panel. Install Cable Clamp around flexible conduit and attach to Jacket Top Panel.
2. Plug Vent Damper Harness Plug into Vent Damper Receptacle in Hydrostat 3200 limit control. See Figure 5-2.

C. Install thermostat. Locate on inside wall approximately 4 feet above floor. Do not install on outside wall, near fireplace, or where influenced by drafts or restricted air flow, hot or cold pipes, lighting fixtures, television, or sunlight. Allow free air movement by avoiding placement of furniture near thermostat.

Heat anticipator setting for non-digital thermostats is 0.2 Amp. For digital thermostats that include an adjustable heat anticipator, set anticipator per thermostat manufacturer recommendations. If room heats above thermostat temperature setting, reduce heat anticipator setting. If boiler short cycles without room reaching desired temperature, increase anticipator setting.

D. Wire thermostat. Provide Class II circuit between thermostat and boiler.

E. Alliance Indirect Water Heater (if used).

Refer to *Alliance Indirect Installation, Operating and Service Instructions* for wiring, piping and additional information.

F. Vent Damper Sequence of Operation. See Figure 6-1 for schematic wiring diagram.

1. The Vent Damper is continuously powered at Terminal 1.
2. When there is a call for heat, the damper relay coil is energized through Terminal 5 if all limits ahead of the damper are satisfied.
3. The relay coil closes contacts which energize the damper motor, causing the damper to open.
4. When the damper blade reaches the fully open position, power is sent back to the ignition circuit through Terminal 2 and the damper motor is de-energized.
5. When the call for heat is satisfied, the damper relay coil is de-energized - closing contacts which energize the damper motor. This causes the damper to close. When the damper blade reaches the fully closed position, the damper motor is de-energized.

POWER FAILURE - The damper blade will stop in the position it was in when power failed. (Combustion can never take place unless the damper blade is in the fully open position).

G. Sequence of Operation and Wiring. Refer to next page for Sequence of Operation and Figure 6-1 for wiring.

6 Electrical *(continued)*

Honeywell EI Sequence of Operation

a. Normal Operation

- i. Thermostat or operating control calls for heat. Vent Damper opens.
- ii. Ignition Module Terminals PV, MV/PV and the Ignition Terminal are energized. Terminals PV and MV/PV power the Pilot Valve in the Gas Valve supplying gas to the Pilot. The Ignition Terminal supplies voltage to the Ignition Electrode creating an electric spark to ignite the Pilot.
- iii. The sensing Circuit between the Q3481B Pilot Burner and the IGNITION MODULE proves the presence of the Pilot Flame Electronically and the Ignition Terminal is de-energized.
- iv. Terminals MV and MV/PV of the IGNITION MODULE are energized and supply power to the Main Gas Valve. The Gas Valve is energized allowing main gas flow, and ignition of Main Burners.
- v. Call for heat ends. Ignition module is de-energized, de-energizing gas valve, and extinguishing pilot and main flame. Vent Damper closes.

b. Safety Shutdown

- i. Limit: Automatically interrupts power to the Ignition Module and Gas Valve(s), extinguishing pilot and main flame, when water temperature exceeds set point. Maximum allowable temperature is 250°F. Circulator continues to operate with call for heat, Vent Damper closes. Normal operation resumes when water temperature falls below set point.
- ii. Blocked Vent Switch: Automatically interrupts main burner operation when excessive flue gas spillage occurs. Circulator continues to operate and Vent Damper remains open with call for heat. If blocked vent switch is activated do not attempt to place boiler in operation. Correct cause of spillage and reset blocked vent switch.

- iii. Flame Roll-out switch: Automatically interrupts main burner operation when flames or excessive heat are present in vestibule. Circulator continues to operate, Vent Damper remains open with call for heat. Control is single use device. If flame roll-out switch is activated, do not attempt to place boiler in operation. Correct cause of spillage and replace flame roll-out switch.

iv. Pilot

- Pilot failure can occur during the start-up or the operating cycle of the boiler. Any pilot failure of the Q3481B Electronic Pilot, after ignition of pilot flame will close the main gas valve in 0.8 seconds.
- For approximately 90 seconds after failure of the Q3481B pilot, the module through the ignition terminal will try to reestablish pilot flame. If no pilot flame can be sensed by the flame rod circuit, terminals PV and MV/PV are de-energized and the module will lock out on safety. Five to six minutes after shutdown, the IGNITION MODULE restarts the ignition sequence. The ignition trial, shutdown, and wait sequence continues until either the pilot lights or the Thermostat is set below room temperature (to end the call for heat). The ignition sequence can be reset by setting down the Thermostat for one minute.

- c. Trouble Shooting Guide. See Page 39.

NOTE: See Hydrolevel 3200 instruction manual packed with control for further details on control operation.

6 Electrical (continued)

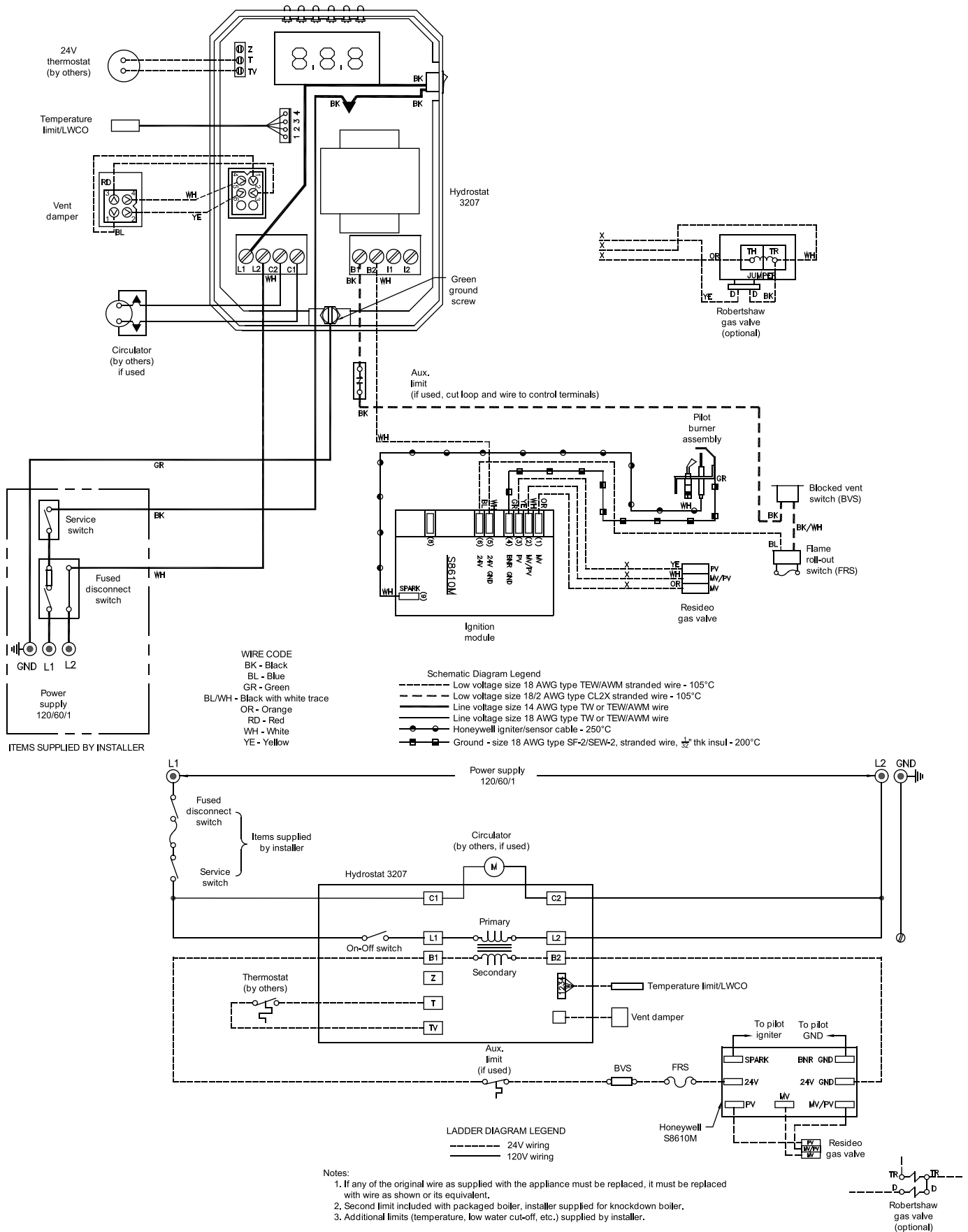

Figure 6-1: Wiring Diagram, Honeywell EI

7 System Start-up

WARNING

- Completely read, understand and follow all instructions in this manual before attempting start-up.
 - Make sure that the area around the boiler is clear and free from combustible materials, gasoline, and other flammable vapors and liquids.
 - Damper must be in open position when appliance main burner is operating.
- A. Safe operation and other performance criteria were met with the gas manifold and control assembly provided on boiler when boiler underwent tests specified in *American National Standard for Gas-Fired Low-Pressure Steam and Hot Water Boilers*, ANSI Z21.13.
- B. Check Main Burners. Main burners must be properly located on support bracket in Base Rear Panel, seated on Main Burner Orifices, and secured with hitch pin clips.
- C. Verify that the venting, water piping, gas piping and electrical system are installed properly. Refer to installation instructions contained in this manual.
- D. Confirm all electrical, water and gas supplies are turned off at the source and that vent is clear of obstructions.
- E. FILL ENTIRE HEATING SYSTEM WITH WATER and vent air from system. Use following procedure on a Series Loop or multi-zoned system installed as per Figure 3-7 to remove air from system when filling.

WARNING

The maximum operating pressure of this boiler is 50 psig. Never exceed this pressure. Do not plug or modify pressure relief valve.

1. Close full port ball valve in boiler supply piping.
2. Isolate all zones by closing zone valves or shut-off valves in supply and return of each zone(s).
3. Attach a hose to the vertical purge valve located prior to the full port ball valve in the system supply piping. (Note - Terminate hose in five gallon bucket at a suitable floor drain or outdoor area).
4. Starting with one circuit at a time, open zone valve or shut-off valve in system supply and return piping.

5. Open purge valve.
 6. Open fill valve (Make-up water line should be located directly after full port ball valve in system supply piping between air scoop and expansion tank).
 7. Allow water to overflow from bucket until discharge from hose is bubble free for 30 seconds.
 8. Close the open zone valve or shut-off valve for the zone being purged of air, then open the zone valve or shut-off valve for the next zone to be purged. Repeat this step until all zones have been purged. At completion, open all zone valves or shut-off valves.
 9. Close purge valve, continue filling the system until the pressure gauge reads the desired cold fill pressure. Close fill valve.
(Note - If make-up water line is equipped with pressure reducing valve, adjust pressure reducing valve to desired cold fill pressure. Follow fill valve manufacturer's instructions).
 10. Open isolation valve in boiler supply piping.
 11. Remove hose from purge valve.
- F. Confirm that the boiler and system have no water leaks.
- G. Prepare to check operation.
1. Obtain gas heating value (in Btu per cubic foot) from gas supplier.
 2. Connect manometer to pressure tap on gas valve. Use 1/8 NPT tapping provided.
 3. Temporarily turn off all other gas-fired appliances.
 4. Turn on gas supply to the boiler gas piping.
 5. Confirm that the supply pressure to the gas valve is 14 in. w.c. or less.
 6. Open the field installed manual gas shut-off valve located upstream of the gas valve on the boiler.
 7. Using soap solution, or similar non-combustible solution, electronic leak detector or other approved method. Check that boiler gas piping, valves, and all other components are leak free. Eliminate any leaks.
 8. Purge gas line of air.
- H. Follow Operating Instructions to place boiler in operation. Refer to label on inside of Front Removable Panel or Figure 7-1.

DANGER

Do not use matches, candles, open flames or other ignition source to check for leaks.



7 System Start-up *(continued)*

FOR YOUR SAFETY READ BEFORE OPERATING

WARNING: If you do not follow these instructions exactly, a fire or explosion may result causing property damage, personal injury, or loss of life.

- A. This appliance is equipped with an ignition device which automatically lights the pilot. Do not try to light the pilot by hand.
- B. BEFORE OPERATING smell all around the appliance area for gas. Be sure to smell next to the floor because some gas is heavier than air and will settle on the floor.
- WHAT TO DO IF YOU SMELL GAS:**
- Do not try to light any appliance.
 - Do not touch any electric switch; do not use any phone in your building.
 - Immediately call your gas supplier from a neighbor's phone. Follow the gas supplier's instructions.
- If you cannot reach your gas supplier, call the fire department.
- C. Use only your hand to turn the gas control knob. Never use tools. If the knob will not turn by hand, don't try to repair it, call a qualified service technician. Force or attempted repair may result in a fire or explosion.
- D. Do not use this appliance if any part has been under water. Immediately call a qualified service technician to inspect the appliance and to replace any part of the control system and any gas control which has been under water.

OPERATING INSTRUCTIONS

1. STOP! Read the safety information above on this label.
2. Set the thermostat to lowest setting.
3. Turn off all electric power to the appliance.
4. This appliance is equipped with an ignition device which automatically lights the pilot. Do not try to light the pilot by hand.
5. Remove front door, if applicable.
6. Locate the gas control valve at the end of the gas supply pipe going into the boiler. The gas control knob is the gray or brown plastic knob located on top of the gas control valve.
7. Rotate gas control knob clockwise  from "ON" position to "OFF". Make sure knob rests against stop.
8. Wait five (5) minutes to clear out any gas. Then smell for gas, including near the floor. If you smell gas, STOP! Follow "B" in the safety information above on this label. If you do not smell gas, go to the next step.
9. Rotate gas control knob counterclockwise  from "OFF" to "ON". Make sure knob rests against stop. Do not force.
10. Replace front door, if applicable.
11. Turn on all electric power to the appliance.
12. Set thermostat to desired setting.
13. If the appliance will not operate, follow the instructions "TO TURN OFF GAS TO APPLIANCE" and call your service technician or gas supplier.

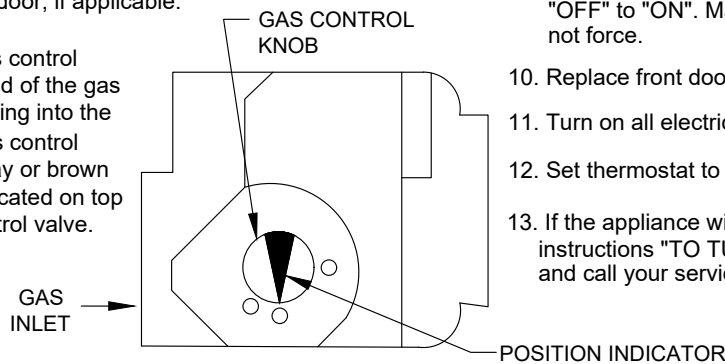

TO TURN OFF GAS TO APPLIANCE

1. Set the thermostat to the lowest setting.
2. Turn off all electric power to the appliance if service is to be performed.
3. Remove front door, if applicable.
4. Rotate gas control knob clockwise  from "ON" position to "OFF". Make sure knob rests against stop.
5. Replace front door, if applicable.

111468-01

Figure 7-1: Operating Instructions

7 System Start-up *(continued)*

⚠ CAUTION

- Avoid operating this boiler in an environment where saw dust, loose insulation fibers, dry wall dust, etc. are present. If boiler is operated under these conditions, the burner interior and ports must be cleaned and inspected daily to insure proper operation.
 - Keep hands and feet away from combustion chamber when placing boiler in operation.
- Check pilot burner flame and main burner flames through observation port.
 - Check pilot flame. Refer to Figure 7-2 for pilot detail.
 - Adjust thermostat to highest setting.
 - Check main burner flames. See Figure 7-3. Flame should have clearly defined inner cones with no yellow tipping. Orange-yellow streaks caused by dust should not be confused with true yellow tipping.

Yellow-tipping indicates lack of primary air. Improper burner alignment on Main Burner Orifice will also affect primary air injection. Adjust primary air shutter as follows:

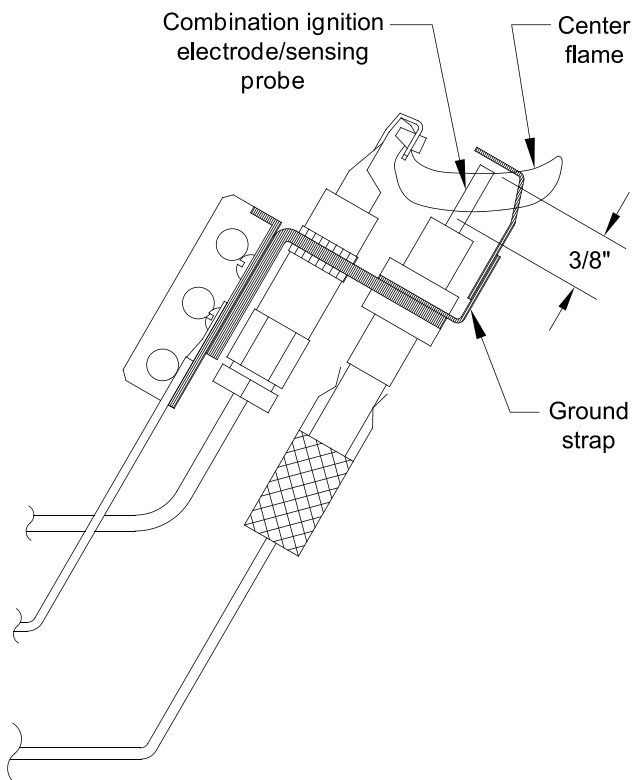

Figure 7-2: Honeywell Q3481B Pilot Flame

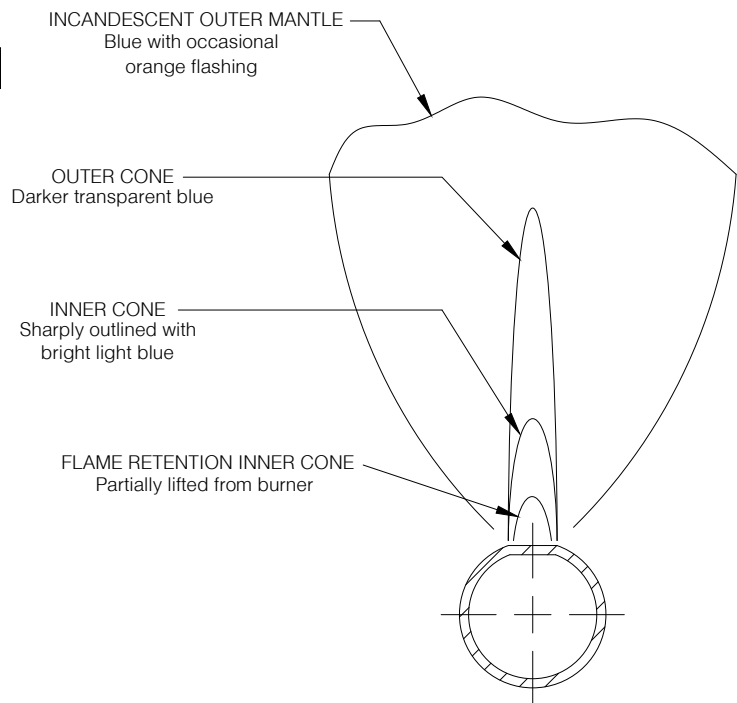

Figure 7-3: Main Burner Flame

- Loosen lock screw.
 - Close air adjustment until yellow tips appear on flames.
 - Slowly open air adjustment until clearly defined inner cones are visible.
 - Tighten lock screw.
 - Use combustion equipment if adjusting air shutters to less than 11/16 in. opening between front edge of burner air shutter and burner mounting ring.
- Adjust thermostat to normal setting.
- Check thermostat or operating control operation. Raise and lower temperature setting to start and stop boiler operation.
 - Check ignition system shut-off.

Disconnect ignitor/sensor cable from ignition module. Gas valve must close and pilot and main burners extinguish.
 - Test LWCO functionality.
 - Press "TEST"/SETTINGS button on Hydrostat 3200. Boiler should shut down.
 - Set thermostat to call for heat and push "TEST"/SETTINGS button on Hydrostat 3200 to simulate low water condition.
 - Red "LOW WATER" LED will illuminate and burner will shut down.
 - Release "TEST"/SETTINGS button and burner will light off.

7 System Start-up *(continued)*

- M. Check high limit function. Set thermostat to higher than normal setpoint. Allow boiler to run until high limit is achieved (180° F default). Burners will shut down. Note - Hydrostat Economy feature may cause boiler to cycle before reaching high limit.
- N. Adjust gas input rate to boiler.
1. Adjust thermostat to highest setting.

Table 7-4: Input Rate

Seconds for One Revolution	Size of Gas Meter Dial			
	One-Half Cu. Ft.	One Cu. Ft.	Two Cu. Ft.	Five Cu. Ft.
30	60	120	240	600
32	56	113	225	563
34	53	106	212	529
36	50	100	200	500
40	45	90	180	450
38	47	95	189	474
40	45	90	180	450
42	43	86	172	430
44	41	82	164	410
46	39	78	157	391
48	37	75	150	375
50	36	72	144	360
52	35	69	138	346
54	33	67	133	333
56	32	64	129	321
58	31	62	124	310
60	30	60	120	300
62	29	58	116	290
64	29	56	112	281
66	29	54	109	273
68	28	53	106	265
70	26	51	103	257
72	25	50	100	250
74	24	48	97	243
76	24	47	95	237
78	23	46	92	231
80	22	45	90	225

2. Check manifold gas pressure. Manifold pressure is listed on rating label. Adjust gas valve pressure regulator as necessary (turn adjustment screw counterclockwise to decrease manifold pressure, or clockwise to increase manifold pressure). If pressure can not be attained, check gas valve inlet pressure. If less than minimum gas supply pressure listed on rating label, contact gas supplier for assistance.
3. Clock gas meter for at least 30 seconds. Use Table 7-4 to determine gas flow rate in Cubic Feet per Hour.
4. Determine Input Rate. Multiply gas flow rate by gas heating value.

WARNING

Failure to properly adjust gas input rate will result in over firing or under firing of the appliance. Improper and unsafe boiler operation may result.

5. Compare measured input rate to input rate stated on rating label.
 - a. Boiler must not be overfired. Reduce input rate by decreasing manifold pressure. Do not reduce more than 0.3 inch w.c. If boiler is still overfired, contact your Burnham Commercial distributor or Regional Office for replacement Gas Orifices.
 - b. Increase input rate if less than 98% of rating plate input. Increase manifold gas pressure no more than 0.3 inch w.c. If measured input rate is still less than 98% of rated input, contact your Burnham Commercial or regional office for larger orifices.
 6. Recheck Main Burner Flame. See Section I
 7. Return other gas-fired appliances to previous conditions of use.
- O. Clean Heating System
- Oil, grease, and other foreign materials which accumulate in new hot water boilers and a new or reworked system should be boiled out, and then thoroughly flushed. A qualified water treatment chemical specialist should be consulted for recommendations regarding appropriate chemical compounds and concentrations which are compatible with local environmental regulations.

7 System Start-up *(continued)*

- P. Check Damper Operation - Vent damper must be in open position when boiler main burners are operating. Start boiler, refer to instructions on damper to determine if damper is in full open position.
- Q. Install Front Removable Panel.
1. Engage top flange (longer of 2 flanges) behind Upper Front Panel.
 2. Swing lower portion of door toward boiler.
 3. Lower door to engage bottom flange behind Lower Front Tie Bar.
- R. Review User's Information Manual and system operation with owner or operator.

IMPORTANT

This boiler is equipped with a feature that saves energy by reducing the boiler water temperature as the heating load decreases. This feature is equipped with an override which is provided primarily to permit the use of an external energy management system that serves the same function. **THIS OVERRIDE MUST NOT BE USED UNLESS AT LEAST ONE OF THE FOLLOWING CONDITIONS IS TRUE:**

- An external energy management system is installed that reduces the boiler water temperature as the heating load decreases.
- This boiler is not used for any space heating.
- This boiler is part of a modular or multiple boiler system having a total input of 300,000 BTU/hr or greater.
- This boiler is equipped with a tankless coil.

8 Service

WARNING

- Service on this boiler should be undertaken only by trained and skilled personnel from a qualified service agency. Inspections should be performed at intervals specified in this manual. Maintain manual in a legible condition.
- Keep boiler area clear and free of combustible materials, gasoline and other flammable vapors and liquids.
- Do not place any obstructions in boiler room that will hinder flow of combustion and ventilation air.
- The service instructions contained in this manual are in addition to the instructions provided by the manufacturer of the boiler components. Follow component manufacturer's instructions. Component manufacturer's instructions were provided with the boiler. Contact component manufacturer for replacement if instructions are missing. Do not install, start up, operate, maintain or service this boiler without reading and understanding all of the component instructions. Do not allow the boiler to operate with altered, disconnected or jumpered components. Only use replacement components identical to those originally supplied by Burnham Commercial.

- A. General. Inspection and service must be conducted annually. Turn off electrical power and gas supply while conducting service or maintenance. Follow instructions TO TURN OFF GAS TO APPLIANCE. See Operating Instructions on inside of Front Removable Door.

DANGER

Explosion Hazard. Electrical Hazard. Shock Hazard. Burn Hazard.

This boiler uses flammable gas, high voltage electricity moving parts, and very hot water under high pressure. Assure that all gas and electric power supplies are turned off and that water temperature is cool before attempting any disassembly for service.

8 Service *(continued)*

CAUTION

- Label all wires prior to disconnection when servicing controls. Wiring errors can cause improper and dangerous operation. Verify proper operation after servicing.
 - Keep hands and feet away from combustion chamber when placing boiler in operation.
- B. Maintenance of Low Water Cut-off. Follow low water cut-off maintenance instructions in HydroStat® manual. If a separate low water cut-off is installed in the piping, follow control manufacturer's instructions.
- C. Vent System. Check for:
1. obstructions
 2. accumulations of soot
 3. deterioration of vent connector, vent accessories, or chimney due to condensation or other reasons
 4. proper support—no sags, particularly in horizontal runs
 5. tightness of joints. Remove all accumulations of soot with wire brush and vacuum
- Remove all obstructions. Replace all deteriorated parts and support properly. Seal all joints.
- D. Remove Main Burners for cleaning, changing orifice plugs, or repairs.
1. Shut down gas boiler in accordance with Operating Instructions on inside of Front Removable Door. Close Manual Shut-off Valve.
 2. Remove Front Removable Door. Raise Lower Front Tie Bar.
 3. Disconnect ignition system.
 7. Hold Main Burner on throat. Lift slightly to raise rear of burner. Push to rear of boiler until burner clears Main Burner Orifice. Lift burners out.
 8. Check burners to be sure they do not contain foreign matter or restrictions. Clean burners with a soft bristle brush, blow any dirt out with compressed air or use a vacuum cleaner. See Figure 8-2.
- E. Inspect Boiler Flueways. Clean if necessary. See Figure 8-2.
1. Shut down gas boiler in accordance with Lighting/Operating Instructions on inside of Front Removable Door. Close Manual Shut-off Valve.
 2. Disconnect vent system. Remove Draft Hood.
 3. Remove Jacket Top Panel.
 4. Remove Canopy from top of boiler.
 5. Remove flue baffles. Refer to Figure 8-2 for instructions on how to remove baffles from flueways. Remove any accumulated scale or soot.
 6. Thoroughly clean flueways with flue brush, removing all scale and soot. See Figure 8-2.
 7. Clean boiler heating surface accessible from combustion chamber with straight handle wire brush.
 8. Reinsert baffles into flueways by reversing steps given in Figure 8-2. Tabs at top of each baffle should rest on top of flue pins.
 9. Install Canopy. See Section 2: Boiler Assembly, Paragraph H.
 10. Install Jacket Top Panel, Draft Hood, Vent Damper and Vent System.
- F. Clean Combustion Chamber by vacuuming. Exercise care to avoid damaging Base Insulation.
- G. Install Burners by reversing procedures used to remove burners. Verify Main Burners are properly located on support bracket in Base Rear Panel, seated on Main Burner Orifices, and secured with hitch pin clips. Verify Main Burner with Pilot Bracket is in proper location. See Table 8-1.
- H. Lubrication. There are no parts requiring lubrication by technician or owner. Circulator bearings are water lubricated.
4. Remove burner access panel(s).
 5. Mark location of Main Burner with Pilot Bracket on manifold.
 6. Remove hitch pin clips from Main Burner Orifices.

CAUTION

Sheet metal parts may have sharp edges or burrs. Use proper Personal Protective Equipment (PPE).

8 Service *(continued)*

Table 8-1: Pilot Burner Location

Boiler Model	Pilot Located Between Burners*
805HE	4 & 5
806HE	5 & 6

* Burners numbered left to right as viewed from front of boiler.

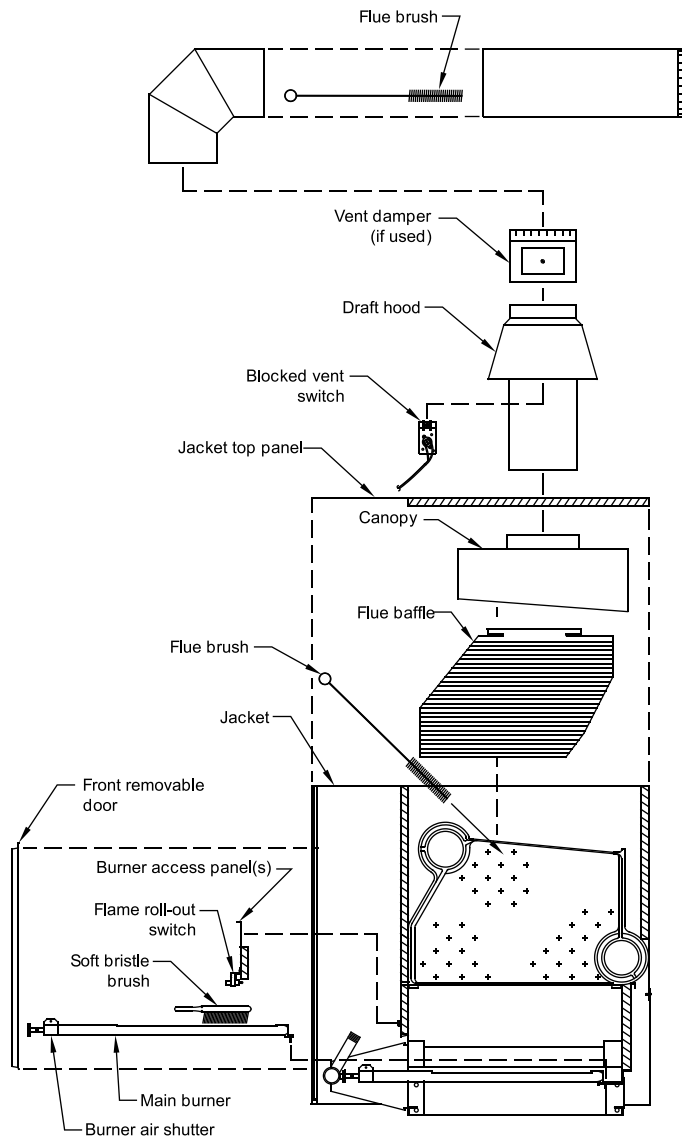

FLUE BAFFLE REMOVAL

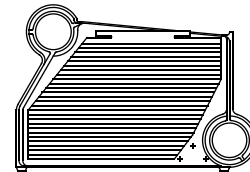

1. Pull up from rear corner of baffle.

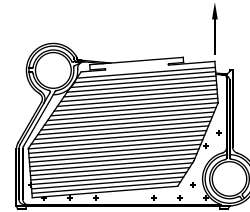

2. Rotate baffle inside flueway while continuing to raise rear corner. It may be necessary to push front of baffle deeper into the flueway to complete the rotation.

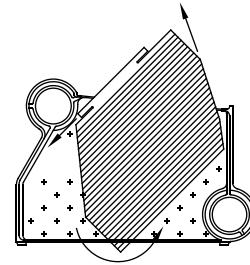

3. Lift baffle out of flueway once edges of the baffle clear the edges of the flueway.

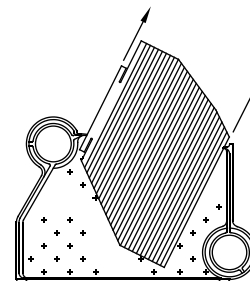
Figure 8-2: Boiler Flueway Cleaning

8 Service *(continued)*

I. Check Electronic Ignition Module Status

See Figure 8-3 for the location of the status LED on the electronic ignition (EI) module. Table 8-5 provides green LED status codes and recommended service action where applicable. See Figure 8-6 for Troubleshooting Guide.

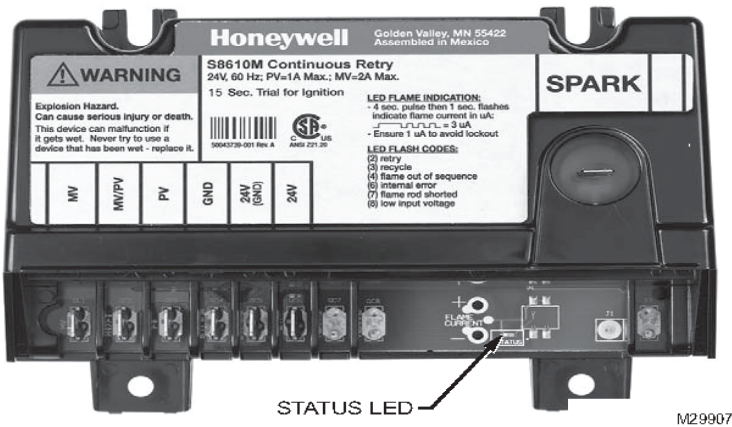

Figure 8-3: Location of LED

J. Flame Current Measurement Procedure

- Pilot flame current in micro amps can be measured using any standard micro-ammeter by inserting meter probes into module hole labeled FLAME CURRENT as shown in Figure 8-4.
- Flame current must be measured with pilot valve open/pilot lit but main valve closed.
- Disconnect MV lead wire from module before measuring flame current. Trying to measure pilot flame current in series with the wiring will not yield accurate reading.
- Minimum steady pilot flame signal must be 1 μ Amp (microampere) DC (direct current).
- For reliable operation flame current should be 2 μ Amp or greater.
- To ensure adequate flame current:
 - Turn off boiler power at circuit breaker or fuse box.
 - Clean the flame rod with emery cloth if required.
 - Make sure electrical connections are clean and tight, and wiring not damaged, repair/replace as needed.
 - Check for igniter/sensor cracked ceramic insulator, replace if needed.
 - Check pilot flame. It must be blue, steady and envelop flame sensing rod 3/8 in. to 1/2 in.

- If needed, adjust pilot flame by turning the gas valve pilot adjustment screw clockwise to decrease or counterclockwise to increase pilot flame. Always reinstall pilot adjustment screw cover and tighten securely upon completion to assure proper gas valve operation.
- Reconnect MV lead wire to module upon satisfactory completion of pilot flame current measurement.
 - Check pilot burner operation/ignition sequence during ignition cycle:
 - Restore boiler power at circuit breaker or fuse box.
 - Set thermostat to call for heat.
 - Watch ignition sequence at burner.
 - If spark does not stop after pilot lights, replace ignition module.
 - If main burners do not light or if main burners light but system locks out, check the module ground wire and gas control as described in the Honeywell Electronic Ignition Troubleshooting Guide, Figure 8-6.

K. Check operation. Refer to Section 7: System Start-up.

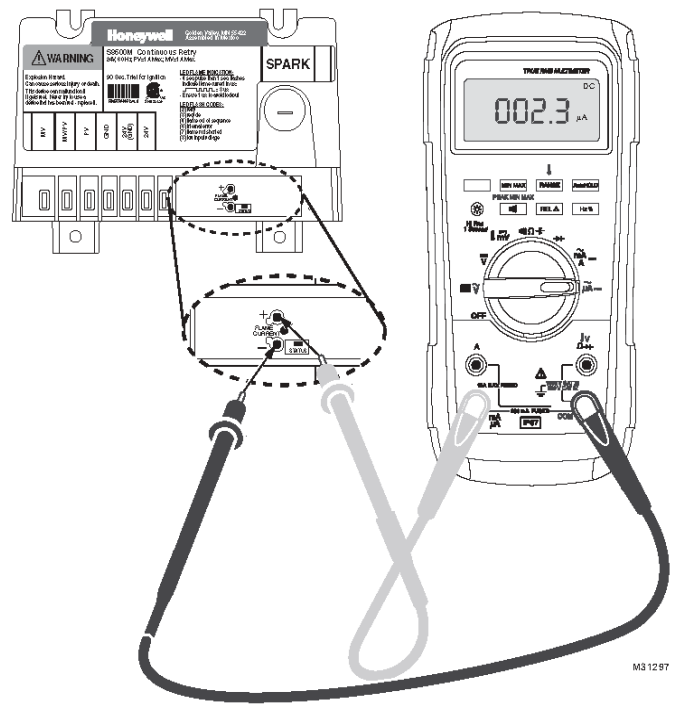

Figure 8-4: Measuring Pilot Flame Current with Micro-ammeter

8 Service *(continued)*

Table 8-5: Green LED Flame Codes

Green LED Flash Code*	Indicates	Next System Action	Recommended Service Action
OFF	No "Call for Heat"	N/A	None
Flash Fast	Power up - internal check	N/A	None
Heartbeat	Normal startup - ignition sequence started (including prepurge)	N/A	None
4 Seconds ON then "x" flashes	Device in run mode. "x" = flame current to the nearest μA	N/A	None
2	5 minute Retry Delay - Pilot flame not detected during trial for ignition	Initiate new trial for ignition after retry delay completed.	If system fails to light on next trial for ignition check gas supply, pilot burner, spark and flame sense wiring, flame rod contamination or out of position, burner ground connection.
3	Recycle - Flame failed during run	Initiate new trial for ignition. Flash code will remain through ignition trial until flame is proved.	If system fails to light on next trial for ignition, check gas supply, pilot burner, flame sense wiring, contamination of flame rod, burner ground connection.
4	Flame sensed out of sequence	If situation self corrects within 10 seconds, control returns to normal sequence. If flame out of sequence remains longer than 10 seconds, control will resume normal operation 1 hour after error is corrected.	Check for pilot flame. Replace gas valve if pilot flame present. If no pilot flame, cycle "Call for Heat." If error repeats, replace control.
6	Control Internal Error	Control remains in wait mode. When fault corrects, control resumes normal operation.	Cycle "Call for Heat". If error repeats, replace control.
7	Flame rod shorted to ground	Control remains in wait mode. When fault corrects, control resumes normal operation.	Check flame sense lead wire for damage or shorting. Check that flame rod is in proper position. Check flame rod ceramic for cracks, damage or tracking.
8	Low secondary voltage supply- (below 15.5 VAC)	Control remains in wait mode. When fault corrects, control resumes normal operation.	Check transformer and AC line for proper input voltage to control. Check with full system load on the transformer.

*Flash Code Descriptions:

- Flash Fast: rapid blinking
- Heartbeat: Constant $\frac{1}{2}$ second bright, $\frac{1}{2}$ second dim cycles.
- 4 second solid on pulse followed by "x" 1 second flashes indicates flame current to the nearest μA . This is only available in run mode.
- A single flash code number signifies that the LED flashes X times at 2Hz, remains off for two seconds, and then repeats the sequence.

8 Service (continued)

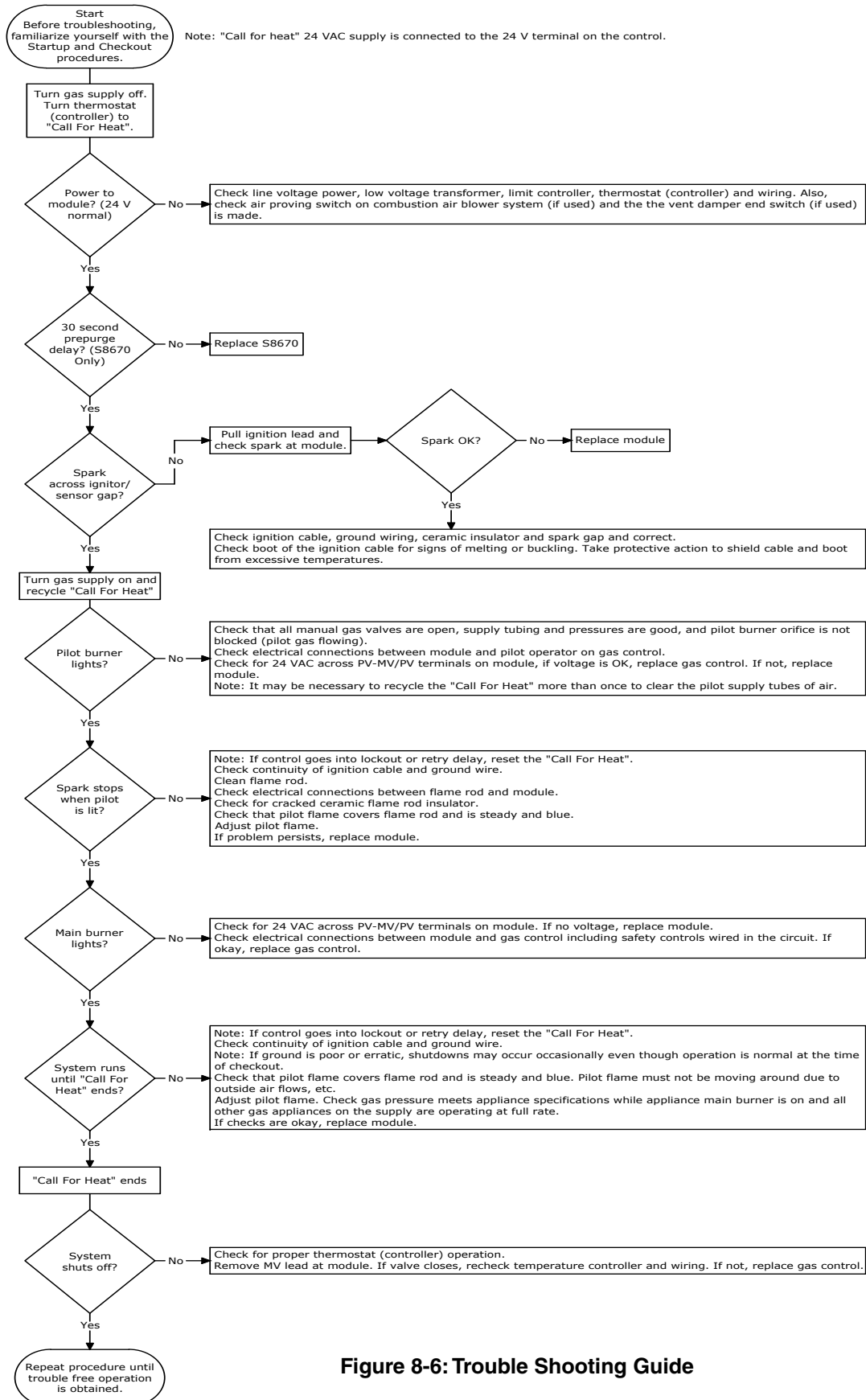

Figure 8-6: Trouble Shooting Guide

9 Service Parts

For service or repairs to boiler, call your heating contractor. When seeking information on boiler, provide Boiler Model Number and Serial Number as shown on Rating Label.

Boiler Model Number	Boiler Serial Number	Installation Date
Heating Contractor		Phone Number
Address		

All Series 8HE Service Parts may be obtained through your local Burnham Commercial Wholesale distributor. Should you require assistance in locating a Burnham Commercial Distributor in your area, or have questions regarding the availability of Burnham Commercial products or repair parts, please contact Burnham Commercial Customer Service at: 888-791-3790 or Fax (717) 293-5803.

9 Service Parts *(continued)*

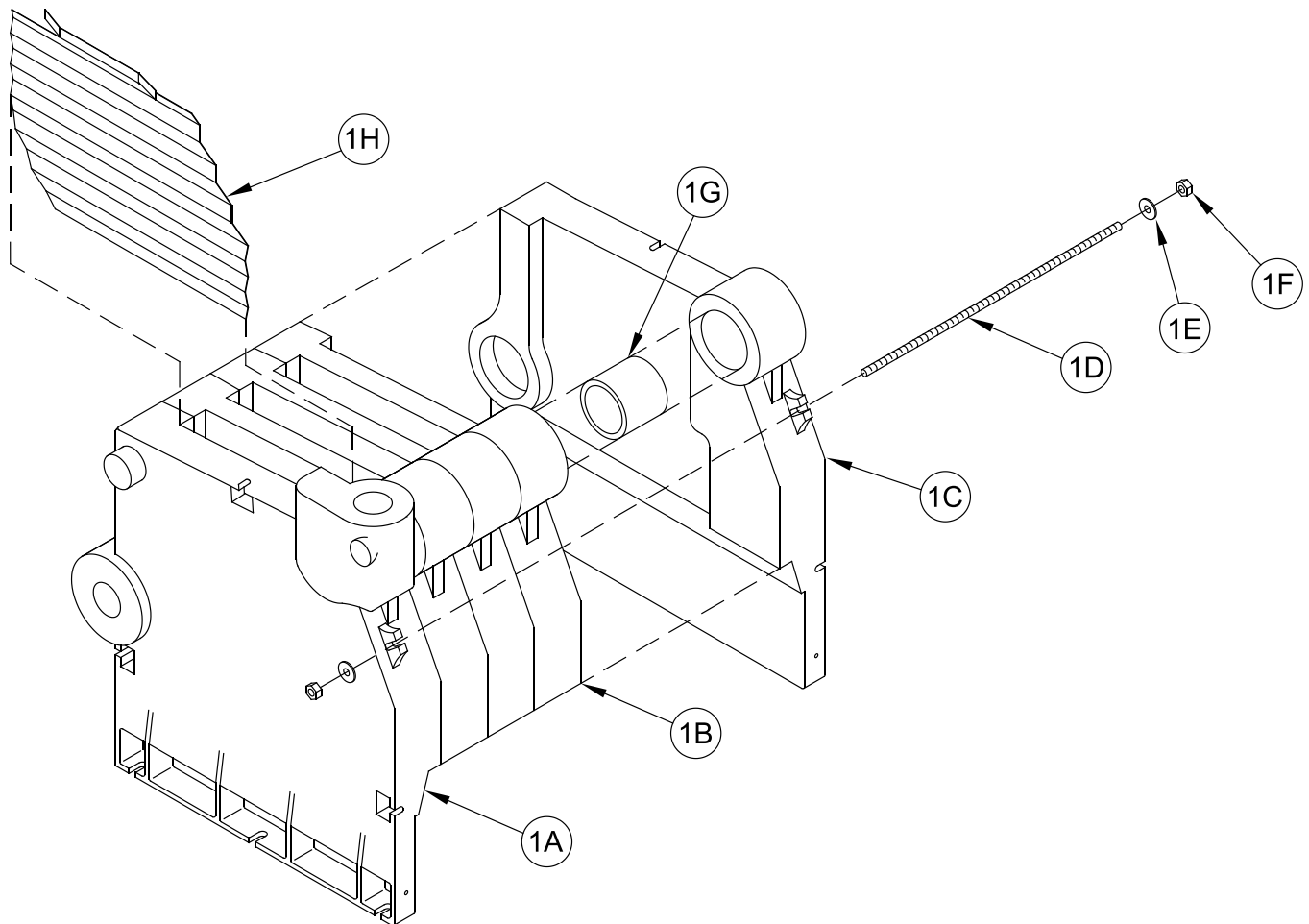

Item No.	Description	Part No.	Quantity	
			805HE	806HE
1. Heat Exchanger Assembly				
1	Complete (Less Flue Baffles)	6171605	1	---
		6171606	---	1
1A	Left End Section	N/A*	1	1
1B	Intermediate Section	N/A*	3	4
1C	Right End Section	N/A*	1	1
1D	Tie Rod	80861032	1	---
		80861033	---	1
1E	Washer, Flat, USS, 3/8 in.	**	4	4
1F	Hex Nut, 3/8 in. -16 Heavy	**	4	4
1G	Push Nipple, 3 in.	N/A*	8	10
1H	Flue Baffle	7111623	4	5

*N/A - Not available as individual item.

** Item to be sourced locally.

9 Service Parts *(continued)*

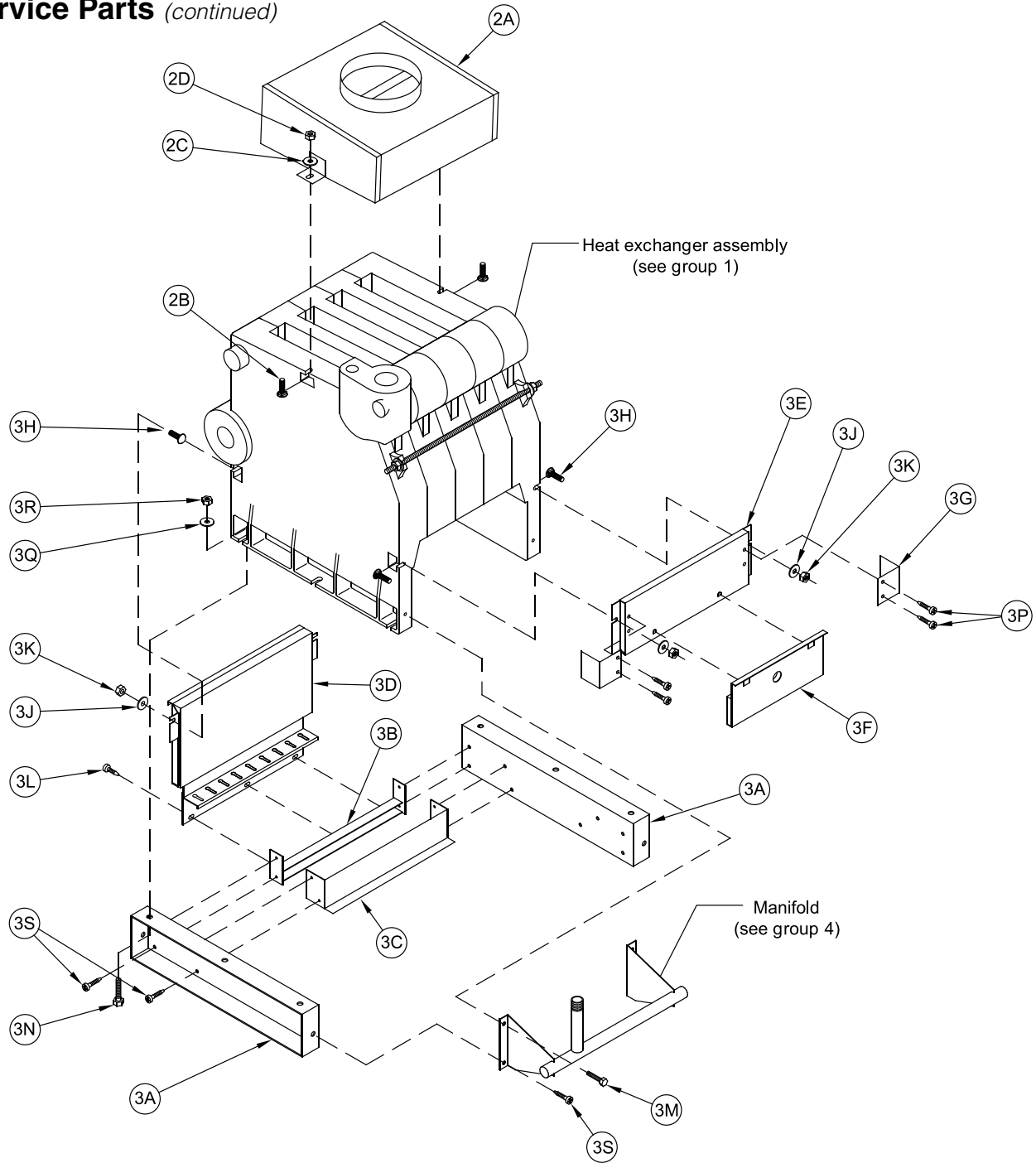

Item No.	Description	Part No.	Quantity	
			805HE	806HE
2. Canopy				
2A	Canopy	111770-01	1	---
		111770-02	---	1
--	Canpoy Seal, Ceramic Fiber Blanket	102741-01	6 ft.	6 ft.
2B	Bolt, Carriage, ¼ - 20 x 1 in.	**	2	2
2C	Washer, ¼ in. Flat	**	2	2
2D	Nut, ¼ in. - 20	**	2	2

** Item to be sourced locally.

9 Service Parts *(continued)*

Item No.	Description	Part No.	Quantity	
			805HE	806HE
3. Base Assembly				
3A	Base End Panel	7181601	2	2
3B	Base Channel Assembly	61816052	1	---
		61816062	---	1
3C	Burner Air Baffle/Diverter	111756-01	1	---
		111756-02	---	1
3D	Base Rear Panel Assembly	111909-05	1	---
		111909-06	---	1
3E	Base Front Panel Assembly	111912-05	1	---
		111912-06	---	1
3F	Burner Access Panel Assembly	111914-05	1	---
		111914-06	---	1
3G	Jacket Attachment Bracket	7041601	4	4
3H	Bolt, Carriage, ¼ - 20 x 1¼ in.	**	4	4
3J	Washer, ¼ in. Flat	**	4	4
3K	Nut, ¼ - 20	**	4	4
3L	Screw, Self Tapping, ¼ - 20 x ½ in.	**	3	4
3M	Screw, Cap, Hex Head, 5/16 in. - 18 x ¾ in.	**	2	2
3N	Screw, Cap, Hex Head, 5/16 - 18 x 1¼ in.	**	6	6
3P	Screw, Sheet Metal, #8 x ½ in.	**	8	8
3Q	Washer, 3/8 in. Flat	**	6	6
3R	Nut, 5/16 in.	**	6	6
3S	Screw, Self Tapping, ¼ - 20 x ¾ in.	**	10	10

** Item to be sourced locally.

9 Service Parts *(continued)*

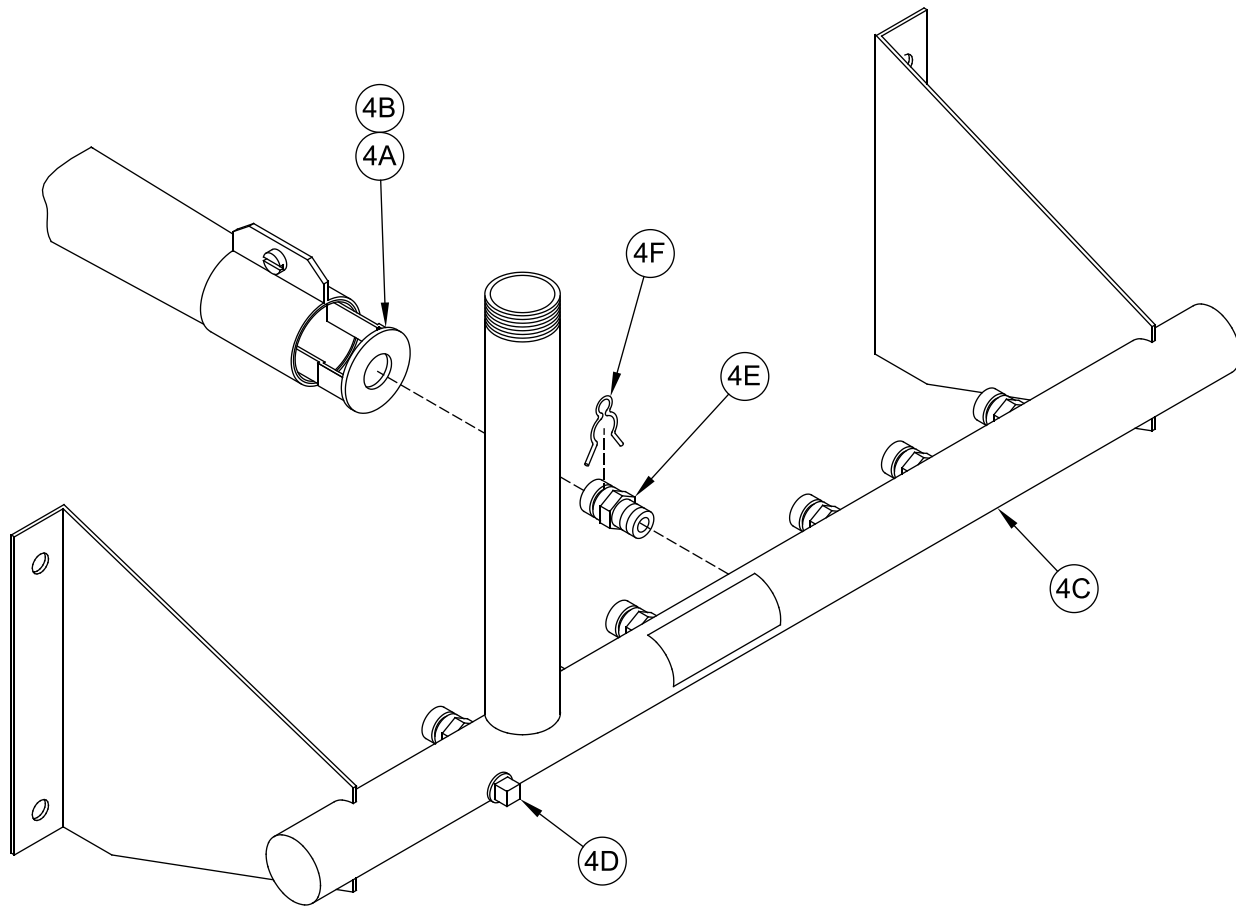

Item No.	Description	Part No.	Quantity	
			805HE	806HE
4. Manifold and Main Burners				
4A	Main Burner	8231602	8	10
4B	Main burner with Pilot Bracket	8231604	1	1
4C	Manifold	82216051	1	---
		82216061	---	1
4D	Pipe Plug, 1/8 NPT (Included with 4C)	---	1	1
4E	Main Burner Orifice, #41 (Natural Gas Only) *	822627	9	11
4F	Hitch Pin Clip	822604	9	11

* Main burner orifice sizes shown for normal altitude (0-2,000 feet). For High Altitude consult factory.

9 Service Parts *(continued)*

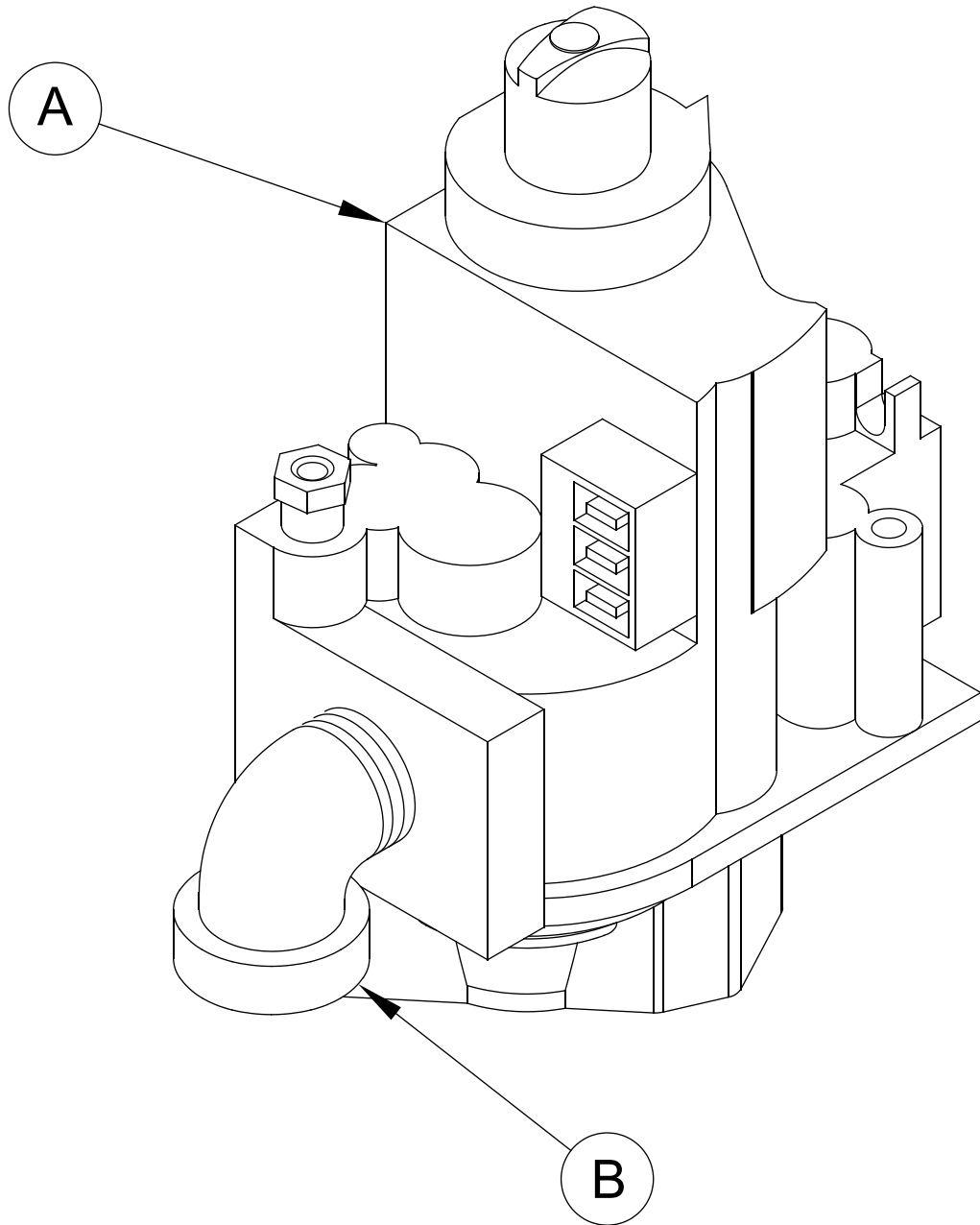

Item No.	Description	Part No.	Size	Quantity
5-1 Gas Train				
A	Gas Valve, Resideo VR8304P4496, Natural Gas, 3/4 in. NPT	81660283	805HE + 806HE	1
B	Reducing Street Elbow, 1 in. x 3/4 in. x 90°	**	805HE + 806HE	1

** Item to be sourced locally.

9 Service Parts *(continued)*

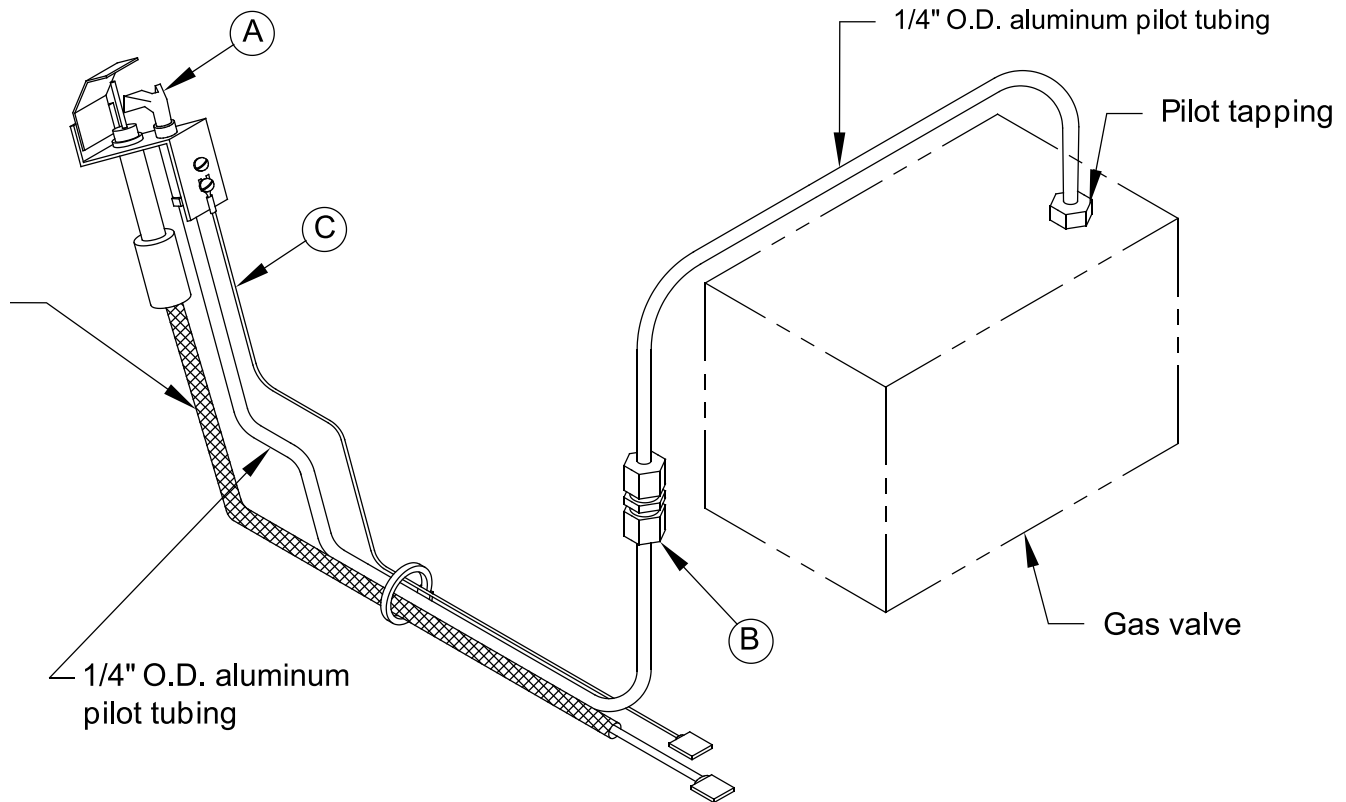

Item No.	Description	Part No.	Size	Quantity
5-2 Pilot Assembly and Piping				
A	Pilot Burner, Honeywell Q3481B1206, Natural Gas	103704-01	805HE + 806HE	1
B	Brass Compression Union, 1/4 in. OD Tube	8236008		1
C	Ground Wire	6136054		1

9 Service Parts *(continued)*

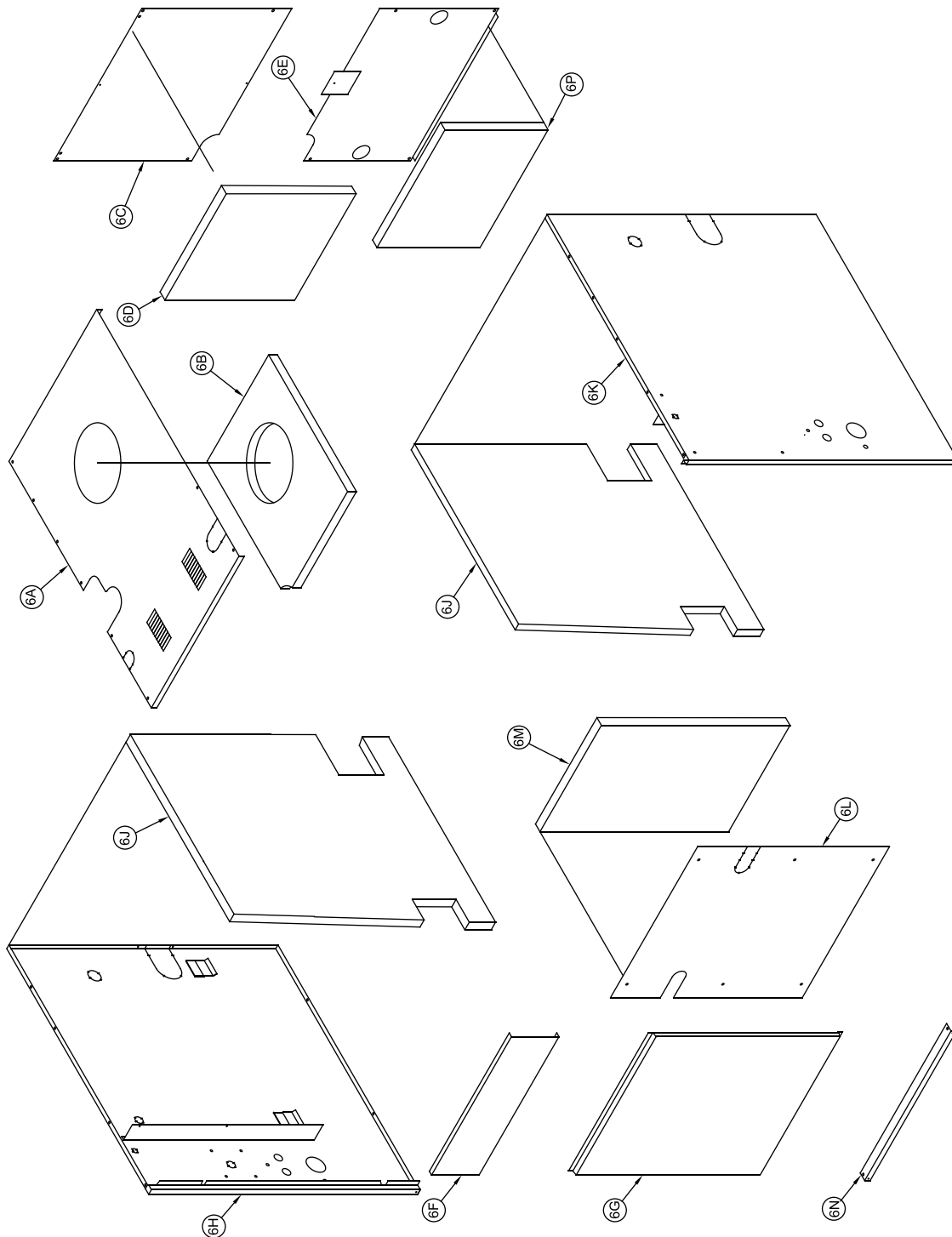

9 Service Parts *(continued)*

Item No.	Description	Part No.	Quantity	
			805HE	806HE
6. Jacket				
6	Complete	111907-05	1	---
		111907-06	---	1
6A	Jacket Top Panel	704160531	1	---
		70416063	---	1
6B	Jacket Top Panel Insulation	111812-01	1	---
		111812-02	---	1
6C	Jacket Upper Rear Panel	70416056	1	---
		70416066	---	1
6D	Jacket Upper Rear Panel Insulation	111816-01	1	---
		111816-02	---	1
6E	Jacket Lower Rear Panel	60416056	1	---
		60416066	---	1
6F	Jacket Upper Front Panel	70416051	1	---
		70416061	---	1
6G	Jacket Front Removable Panel	7041605	1	---
		7041606	---	1
6H	Jacket Left Side Panel	6041601	1	1
6J	Jacket Left and Right Side Panel Insulation Pieces	111814-01	2	2
6K	Jacket Right Side Panel	6041602	1	1
6L	Jacket Vestibule Panel	111784-01	1	---
		111784-02	---	1
6M	Jacket Vestibule Panel Insulation Piece	111811-01	1	---
		111811-02	---	1
6N	Jacket Lower Front Tie Bar	70416052	1	---
		70416062	---	1
6P	Jacket Lower Rear Panel Insulation	111817-01	1	---
		111817-02	---	1

9 Service Parts *(continued)*

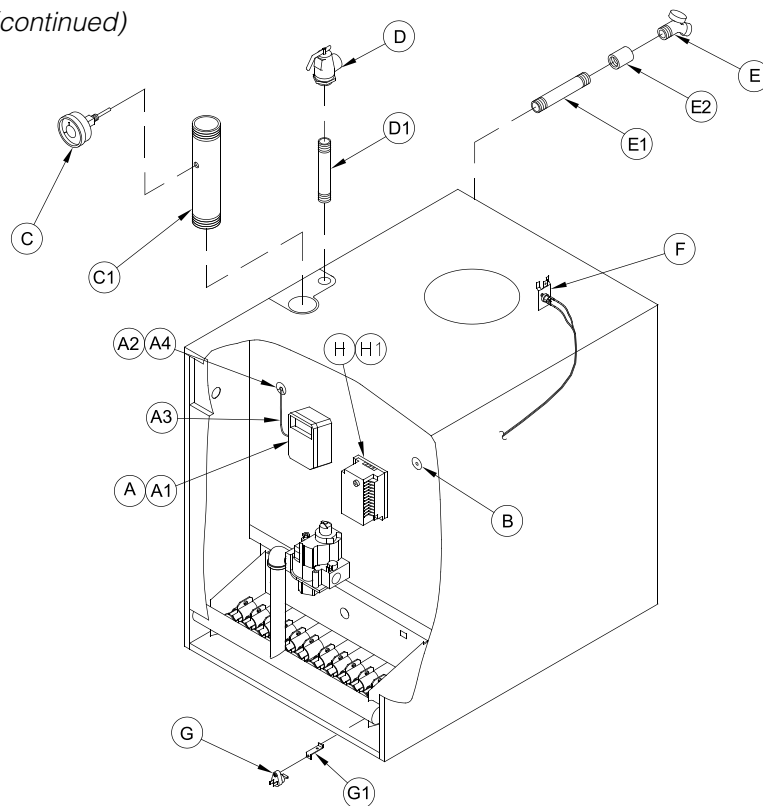

Item No.	Description	Part No.	Quantity	
			805HE	806HE
7. Trim and Miscellaneous Controls				
A	Hydrostat 3200 with Sensor	104873-01	1	1
A1	Remote Mount Bracket Assembly	104877-01	1	1
A2	Electrowell, Hydrostat 3200	105203-01	1	1
A3	Replacement 12 in. Sensor	105944-01	1	1
A4	Spring Clip	102422-01	1	1
B	Immersion Well, 3/4 in. NPT x 3 in. Insul. Depth	80160452	1	1
C	Temperature - Pressure Gauge	100282-01	1	1
C1	Nipple, 2 NPT x 10 in. w/Gauge Tapping	8061601	1	1
D	Pressure Relief Valve, 3/4 NPT, 50 psi	103837-01	1	1
D1	Nipple, 3/4 NPT x 3 1/2 in.	**	1	1
E	Drain Valve, 3/4 NPT, Conbraco 35-302-03	806603061	1	1
E1	Nipple, 3/4 NPT x 3 1/2 in.	**	1	1
E2	Coupling, 3/4 NPT	**	1	1
F	Blocked Vent Switch Replacement Assembly	6016058	1	1
G	Flame Roll-out Switch	80160044	1	1
G1	Flame Roll-out Switch Mounting Bracket	7181612	1	1
H	Ignition Module, Honeywell S8610M3009	100958-01	1	1
H1	Module Support Bracket	7016001	1	1
J	Hydrostat 3200, Resideo S8610M, FRS, and BVS Wiring Harness (not depicted)	111746-01	1	1
K	Gas Valve to ignition Module Wiring Harness (not depicted)	104871-01	1	1
L	Green Ground Wire (not depicted)	6136054	1	1

** Item to be sourced locally.

9 Service Parts *(continued)*

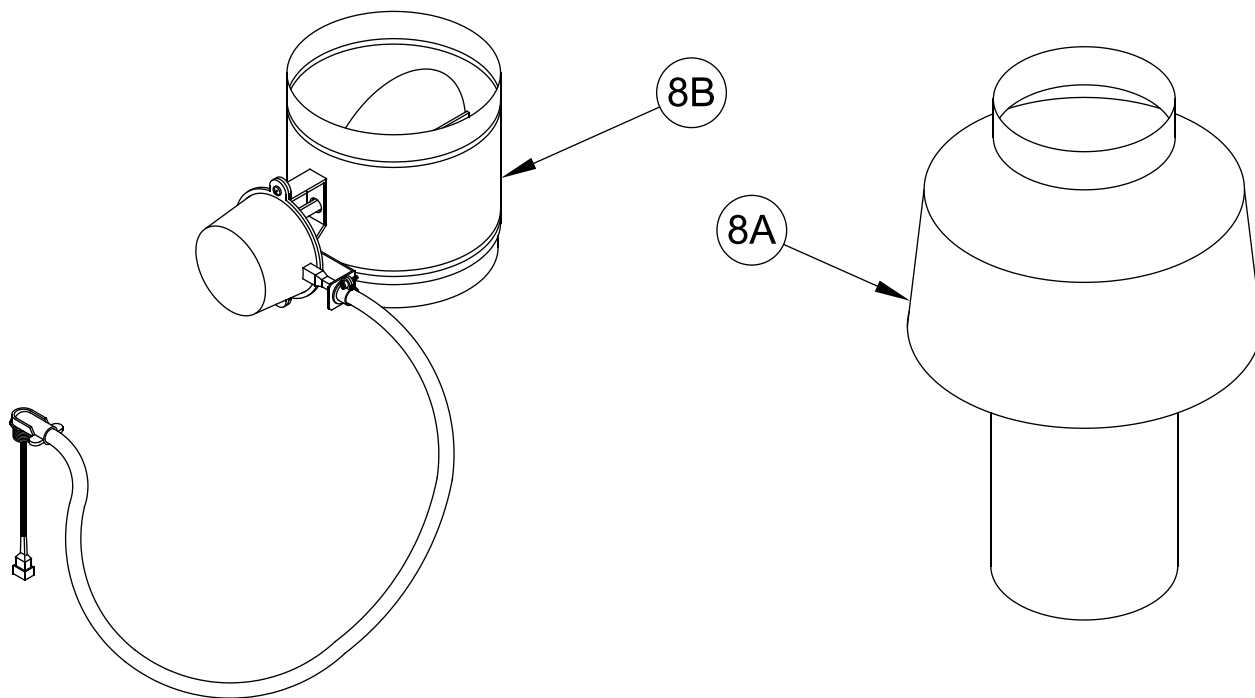

VENT DAMPER

DRAFT HOOD

Item No.	Description	Part No.	Quantity	
			805HE	806HE
8. Draft Hood and Automatic Vent Damper				
8A	Draft Hood	109434-01	1	
8A	Drafthood	8111604		1
8B	Automatic Vent Damper, 7 in.			
	Field Controls GVD-7PL	8116324	1	1

Limited Warranty

For Commercial Grade Boilers

Using Cast Iron, Carbon Steel,
or Stainless Steel Heat Exchangers
and Parts/Accessories

Subject to the terms and conditions set forth below, Burnham Commercial, Lancaster, Pennsylvania hereby extends the following limited warranties to the original owner of a commercial grade water or steam boiler or Burnham Commercial supplied parts and/or accessories manufactured and shipped on or after October 1, 2009:

ONE YEAR LIMITED WARRANTY ON COMMERCIAL GRADE BOILERS AND PARTS / ACCESSORIES SUPPLIED BY BURNHAM COMMERCIAL.

Burnham Commercial warrants to the original owner that its commercial grade water and steam boilers and parts/accessories comply at the time of manufacture with recognized hydronic industry standards and requirements then in effect and will be free of defects in material and workmanship under normal usage for a period of one year from the date of original installation. If any part of a commercial grade boiler or any part or accessory provided by Burnham Commercial is found to be defective in material or workmanship during this one year period, Burnham Commercial will, at its option, repair or replace the defective part (not including labor).

HEAT EXCHANGER WARRANTIES

Burnham Commercial warrants to the original owner that the heat exchanger of its commercial grade boilers will remain free from defects in material and workmanship under normal usage for the time period specified in the chart below to the original owner at the original place of installation. If a claim is made under this warranty during the "No Charge" period from the date of original installation, Burnham Commercial will, at its option, repair or replace the heat exchanger (not including labor). If a claim is made under this warranty after the expiration of the "No Charge" period from the date of original installation, Burnham Commercial will, at its option and upon payment of the pro-rated service charge set forth below, repair or replace the heat exchanger. The service charge applicable to a heat exchanger warranty claim is based upon the number of years the heat exchanger has been in service and will be determined as a percentage of the retail price of the heat exchanger model involved at the time the warranty claim is made as follows:

Years in Service	Service Charge as a % of Retail Price									
	1	2	3	4	5	6	7	8	9	10+
Cast Iron	No Charge									100
Carbon Steel	No Charge	100								
Stainless Steel	No Charge				20	40	60	80	100	

NOTE: If the heat exchanger involved is no longer available due to product obsolescence or redesign, the value used to establish the retail price will be the published price as set forth in Burnham Commercial Repair Parts Pricing where the heat exchanger last appeared or the current retail price of the then nearest equivalent heat exchanger, whichever is greater.

ADDITIONAL TERMS AND CONDITIONS

- Applicability: The limited warranties set forth above are extended only to the original owner at the original place of installation within the United States and Canada. These warranties are applicable only to boilers, parts, or accessories designated as commercial grade by Burnham Commercial and installed and used exclusively for purposes of commercial space heating or domestic hot water generation through a heat exchanger (or a combination for such purposes) and do not apply to residential grade products or industrial uses.
- Components Manufactured by Others: Upon expiration of the one year limited warranty on commercial grade boilers, all boiler components other than heat exchangers manufactured by others but furnished by Burnham Commercial (such as oil burner, circulator and controls) will be subject only to the manufacturer's warranty, if any.
- Proper Installation: The warranties extended by Burnham Commercial are conditioned upon the installation of the commercial grade boiler, parts, and accessories in strict compliance with Burnham Commercial installation instructions. Burnham Commercial specifically disclaims liability of any kind caused by or relating to improper installation.
- Proper Use and Maintenance: The warranties extended by Burnham Commercial are conditioned upon the use of the commercial grade boiler, parts, and accessories for its intended purposes and its maintenance accordance with Burnham Commercial recommendations and hydronics industry standards. For proper installation, use, and maintenance, see all applicable sections of the Installation and Operating, and Service Instructions Manual furnished with the unit.
- This warranty does not cover the following:
 - Expenses for removal or reinstallation. The owner will be responsible for the cost of removing and reinstalling the alleged defective part or its replacement and all labor and material connected therewith, and transportation to and from Burnham Commercial.
 - Components that are part of the heating system but were not furnished by Burnham Commercial as part of the commercial boiler.
 - Improper burner adjustment, control settings, care or maintenance.
 - This warranty cannot be considered as a guarantee of workmanship of an installer connected with the installation of the Burnham Commercial boiler, or as imposing on Burnham Commercial liability of any nature for unsatisfactory performance as a result of faulty workmanship in the installation, which liability is expressly disclaimed.

- Boilers, parts, or accessories installed outside the 48 contiguous United States, the State of Alaska and Canada.
 - Damage to the boiler and/or property due to installation or operation of the boiler that is not in accordance with the boiler installation and operating instruction manual.
 - Any damage or failure of the boiler resulting from hard water, scale buildup or corrosion the heat exchanger.
 - Any damage caused by improper fuels, fuel additives or contaminated combustion air that may cause fireside corrosion and/or clogging of the burner or heat exchanger.
 - Any damage resulting from combustion air contaminated with particulate which cause clogging of the burner or combustion chamber including but not limited to sheetrock or plasterboard particles, dirt, and dust particulate.
 - Any damage, defects or malfunctions resulting from improper operation, maintenance, misuse, abuse, accident, negligence including but not limited to operation with insufficient water flow, improper water level, improper water chemistry, or damage from freezing.
 - Any damage caused by water side clogging due to dirty systems or corrosion products from the system.
 - Any damage resulting from natural disaster.
 - Damage or malfunction due to the lack of required maintenance outlined in the Installation and Operating Manuals furnished with the unit.
6. Exclusive Remedy: Burnham Commercial obligation for any breach of these warranties is limited to the repair or replacement of its parts (not including labor) in accordance with the terms and conditions of these warranties.
7. Limitation of Damages: Under no circumstances shall Burnham Commercial be liable for incidental, indirect, special or consequential damages of any kind whatsoever under these warranties, including, but not limited to, injury or damage to persons or property and damages for loss of use, inconvenience or loss of time. Burnham Commercial liability under these warranties shall under no circumstances exceed the purchase price paid by the owner for the commercial grade boiler involved. Some states do not allow the exclusion or limitation of incidental or consequential damages, so the above limitation or exclusion may not apply to you.
8. Limitation of Warranties: These warranties set forth the entire obligation of Burnham Commercial with respect to any defect in a commercial grade boiler, parts, or accessories and Burnham Commercial shall have no express obligations, responsibilities or liabilities of any kind whatsoever other than those set forth herein. These warranties are given in lieu of all other express warranties.

ALL APPLICABLE IMPLIED WARRANTIES, IF ANY, INCLUDING ANY WARRANTY OF MERCHANTABILITY OR FITNESS FOR A PARTICULAR PURPOSE ARE EXPRESSLY LIMITED IN DURATION TO A PERIOD OF ONE YEAR EXCEPT THAT IMPLIED WARRANTIES, IF ANY, APPLICABLE TO THE HEAT EXCHANGER IN A COMMERCIAL GRADE BOILER SHALL EXTEND TO THE ORIGINAL OWNER FOR THE TIME SPECIFIED IN THE HEAT EXCHANGER SECTION SHOWN ABOVE AT THE ORIGINAL PLACE OF INSTALLATION. SOME STATES DO NOT ALLOW LIMITATION ON HOW LONG AN IMPLIED WARRANTY LASTS, SO THE ABOVE LIMITATION MAY NOT APPLY TO YOU.

PROCEDURE FOR OBTAINING WARRANTY SERVICE

In order to assure prompt warranty service, the owner is requested to complete and mail the Warranty Card provided with the product or register product online at www.burnhamcommercialcastiron.com within ten days after the installation of the boiler, although failure to comply with this request will not void the owner's rights under these warranties. Upon discovery of a condition believed to be related to a defect in material or workmanship covered by these warranties, the owner should notify the installer, who will in turn notify the distributor. If this action is not possible or does not produce a prompt response, the owner should write to Burnham Commercial, P.O. Box 3939, Lancaster, PA 17604, giving full particulars in support of the claim. The owner is required to make available for inspection by Burnham Commercial or its representative the parts claimed to be defective and, if requested by Burnham Commercial to ship these parts prepaid to Burnham Commercial at the above address for inspection or repair. In addition, the owner agrees to make all reasonable efforts to settle any disagreement arising in connection with a claim before resorting to legal remedies in the courts.

THIS WARRANTY GIVES YOU SPECIFIC LEGAL RIGHTS AND YOU MAY ALSO HAVE OTHER RIGHTS WHICH VARY FROM STATE TO STATE.



Burnham Commercial Boilers
P.O. Box 3939
Lancaster, PA 17604
1-888-791-3790
www.burnhamcommercial.com