

BURNHAM®

Commercial Boilers

RATINGS AND DATA

Shell Diameter : 27 $\frac{3}{4}$ "

Heating Surface - Sq. Ft.
 Fireside - 101
 Waterside - 107

Firetubes
 Number - 41
 Diameter - 2" O.D.

Furnace
 Volume (Cubic Feet) - 14.6

Water Content
 Steam - 105 Gal. (U.S.)
 Water - 148 Gal. (U.S.)

Approximate Weight (Lb.)
 Dry - 2400
 Wet (Steam) - 3270
 Wet (Water) - 3630

LEGEND CONNECTIONS

- A = 4" SUPPLY
- B = 3" RETURN
- C = 3" x 4" HANDHOLE
- D = 1" WATER COLUMN
- E = 3/4" AQUASTAT
- F = 1-1/2" SURFACE BLOWOFF/WASHOUT
- G = 1/2" TEMPERATURE GAUGE
- H = 1-1/4" SAFETY/RELIEF VALVE
- J = 1" AUXILIARY CONNECTION
- K = 7" NOMINAL FLUE DIAMETER

LEGEND

- BS = BOTH SIDES
- RS = RIGHT SIDE
- LS = LEFT SIDE
- FB = FRONT OF BOILER
- RB = REAR OF BOILER

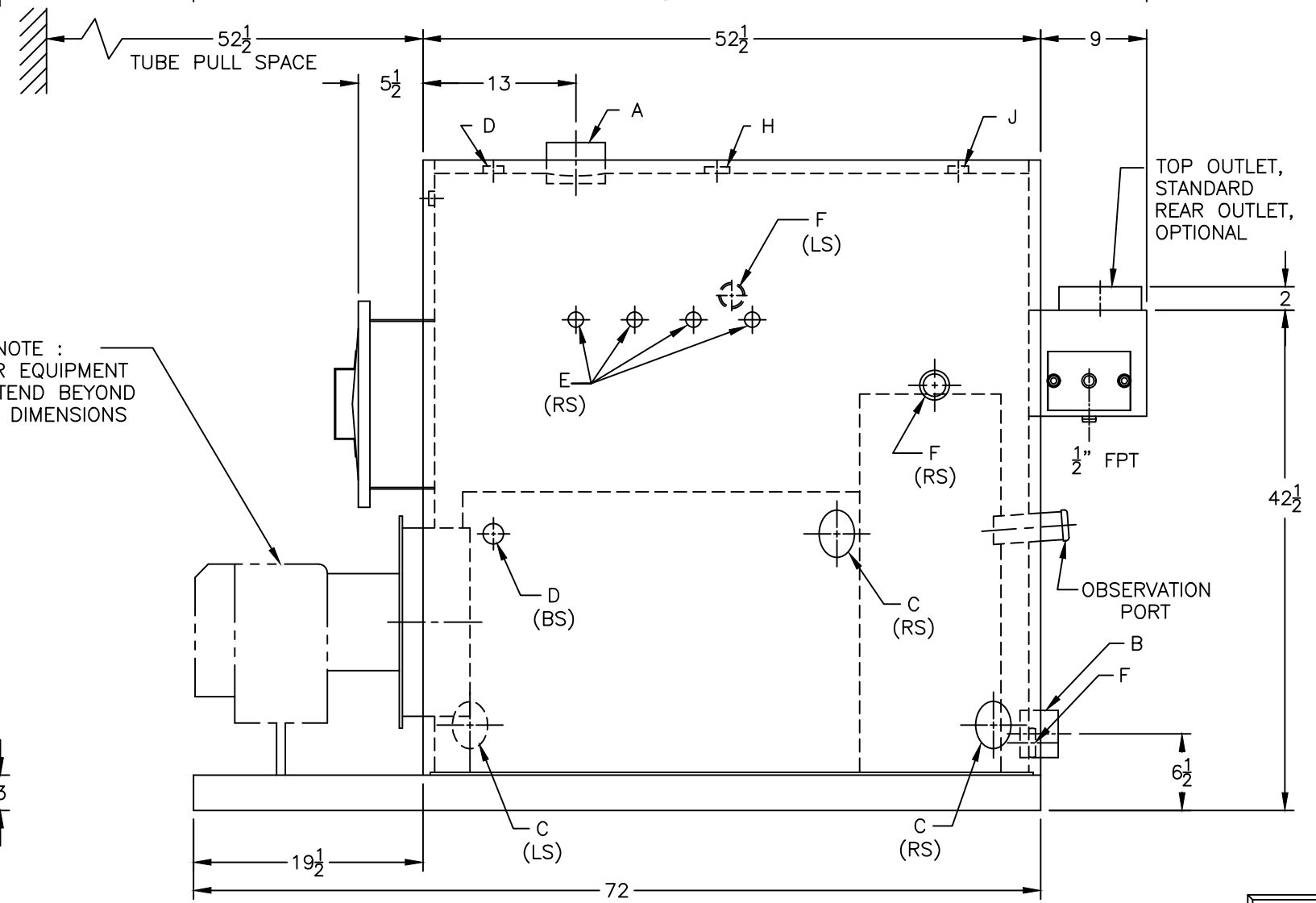
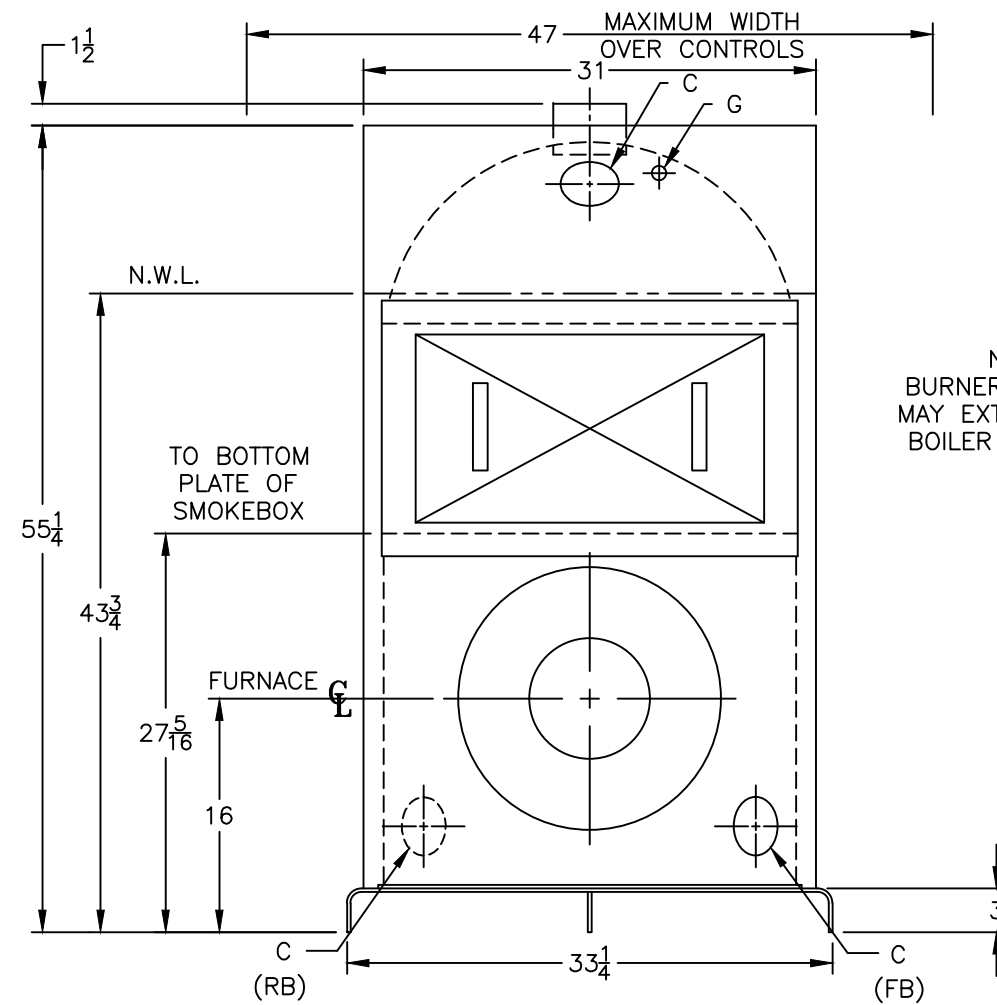
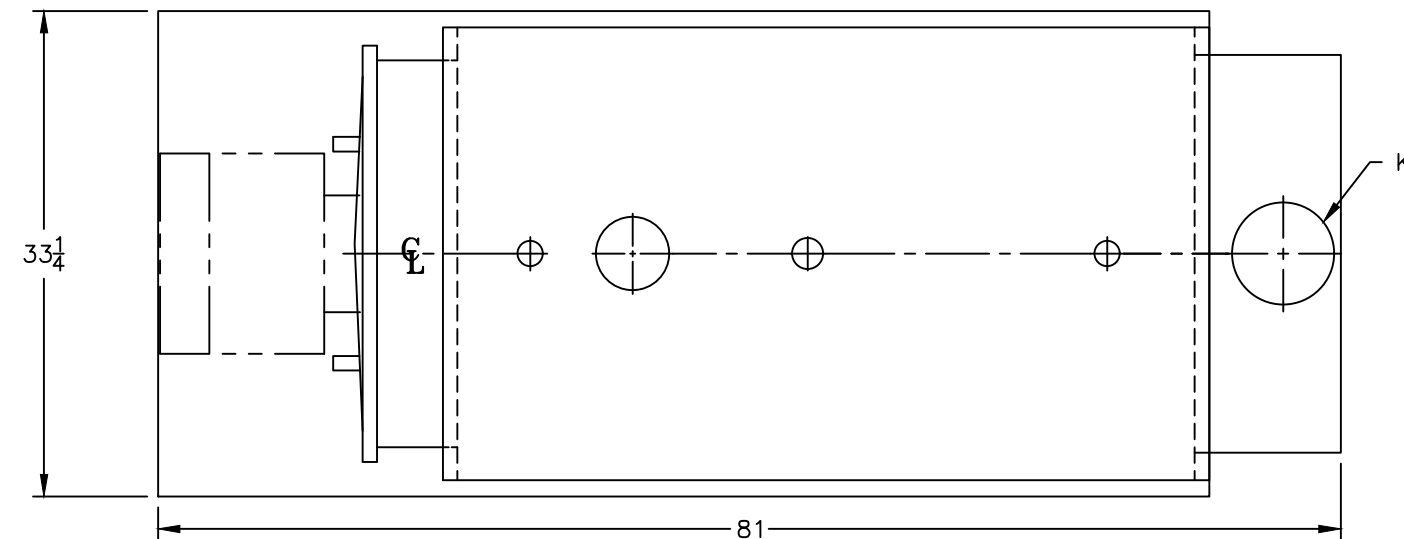

NOTE :
 BURNER EQUIPMENT
 MAY EXTEND BEYOND
 BOILER DIMENSIONS

SPECIFICATIONS SUBJECT TO CHANGE WITHOUT NOTICE ALL CONNECTIONS ARE THREADED UNLESS OTHERWISE SPECIFIED
 THIS DOCUMENT CONTAINS CONFIDENTIAL INFORMATION WHICH IS THE PROPERTY OF BURNHAM COMMERCIAL. THIS DOCUMENT MAY NOT BE REPRODUCED, TRANSFERRED OR USED, OR ITS CONTENTS DISCLOSED, WITHOUT THE WRITTEN PERMISSION OF THE OWNER.

MODEL 4FH-107A