

BURNHAM®

Commercial Boilers

RATINGS AND DATA

Shell Diameter : 72"

Heating Surface - Sq. Ft.
 Fireside - 1654
 Waterside - 1786

Firetubes
 Number - 203
 Diameter - 3" O.D.

Furnace
 Volume (Cubic Feet) - 230.6

Water Content
 Steam - 1470 Gal. (U.S.)
 Water - 1829 Gal. (U.S.)

Approximate Weight (Lb.)
 Dry - 21700
 Wet (Steam) - 33900
 Wet (Water) - 36950

LEGEND CONNECTIONS

- A = 10" FLANGED SUPPLY
- B = 6" RETURN (STEAM)
- 8" FLANGED RETURN (WATER)
- C = 3" x 4" HANDHOLE
- D = 1" WATER COLUMN
- E = 3/4" AQUASTAT
- F = 2" WASHOUT
- G = 1-1/2" SURFACE BLOWOFF
- H = 2-1/2" SAFETY/RELIEF VALVE
- J = 12" X 16" MANHOLE RING
- K = 38" NOMINAL FLUE DIAMETER

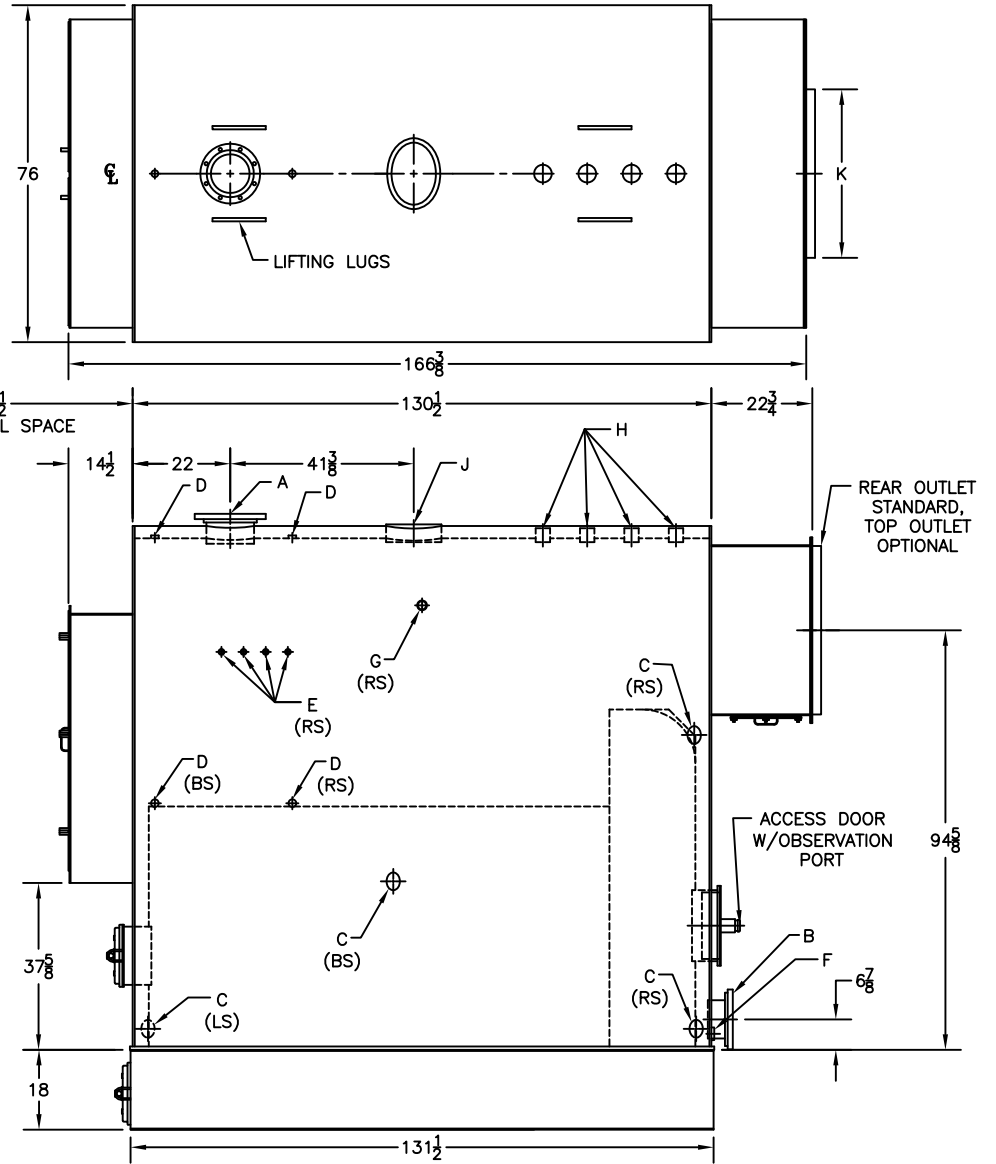
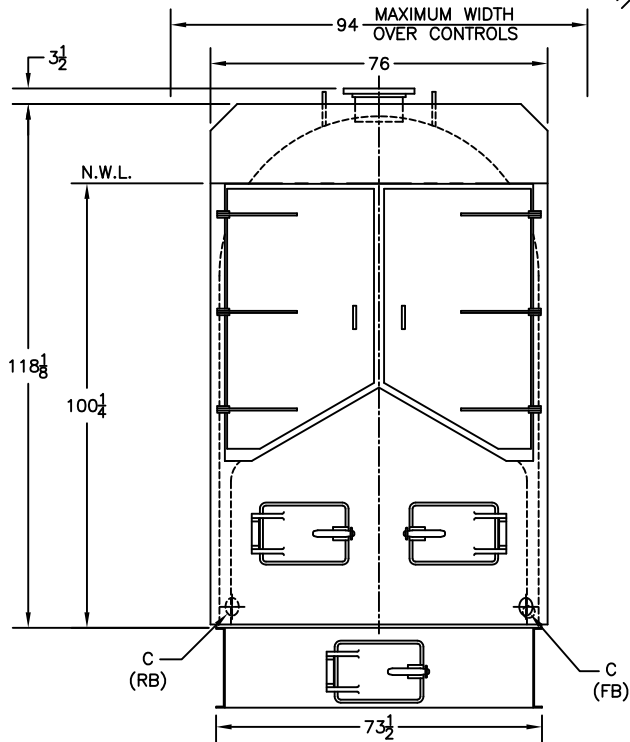

SPECIFICATIONS SUBJECT TO CHANGE WITHOUT NOTICE ALL CONNECTIONS ARE THREADED UNLESS OTHERWISE SPECIFIED
 THIS DOCUMENT CONTAINS CONFIDENTIAL INFORMATION WHICH IS THE PROPERTY OF BURNHAM COMMERCIAL. THIS DOCUMENT MAY NOT BE REPRODUCED, TRANSFERRED OR USED, OR ITS CONTENTS DISCLOSED, WITHOUT THE WRITTEN PERMISSION OF THE OWNER.

MODEL 4N-1654

DEC 2009 TS-3-65-2