

BURNHAM®

Commercial Boilers

LEGEND CONNECTIONS

- A = 10" FLANGED SUPPLY
- B = 4" RETURN
- C = 3" x 4" HANDHOLE
- D = 1" WATER COLUMN
- E = 3/4" AQUASTAT
- F = 1-1/2" SURFACE BLOWOFF/WASHOUT
- G = 1/2" TEMPERATURE GAUGE
- H = 1-1/2" RELIEF VALVE
- 2" RELIEF VALVE
- J = 1" AUXILIARY CONNECTION
- K = 24" NOMINAL FLUE DIAMETER

RATINGS AND DATA

Shell Diameter : 47 $\frac{1}{2}$ "

Heating Surface - Sq. Ft.
 Fireside - 463
 Waterside - 500

Firetubes
 Number - 76
 Diameter - 3" O.D.

Furnace
 Volume (Cubic Feet) - 68.3

Water Content
 Steam - 487 Gal. (U.S.)
 Water - 602 Gal. (U.S.)

Approximate Weight (Lb.)
 Dry - 8000
 Wet (Steam) - 12040
 Wet (Water) - 13020

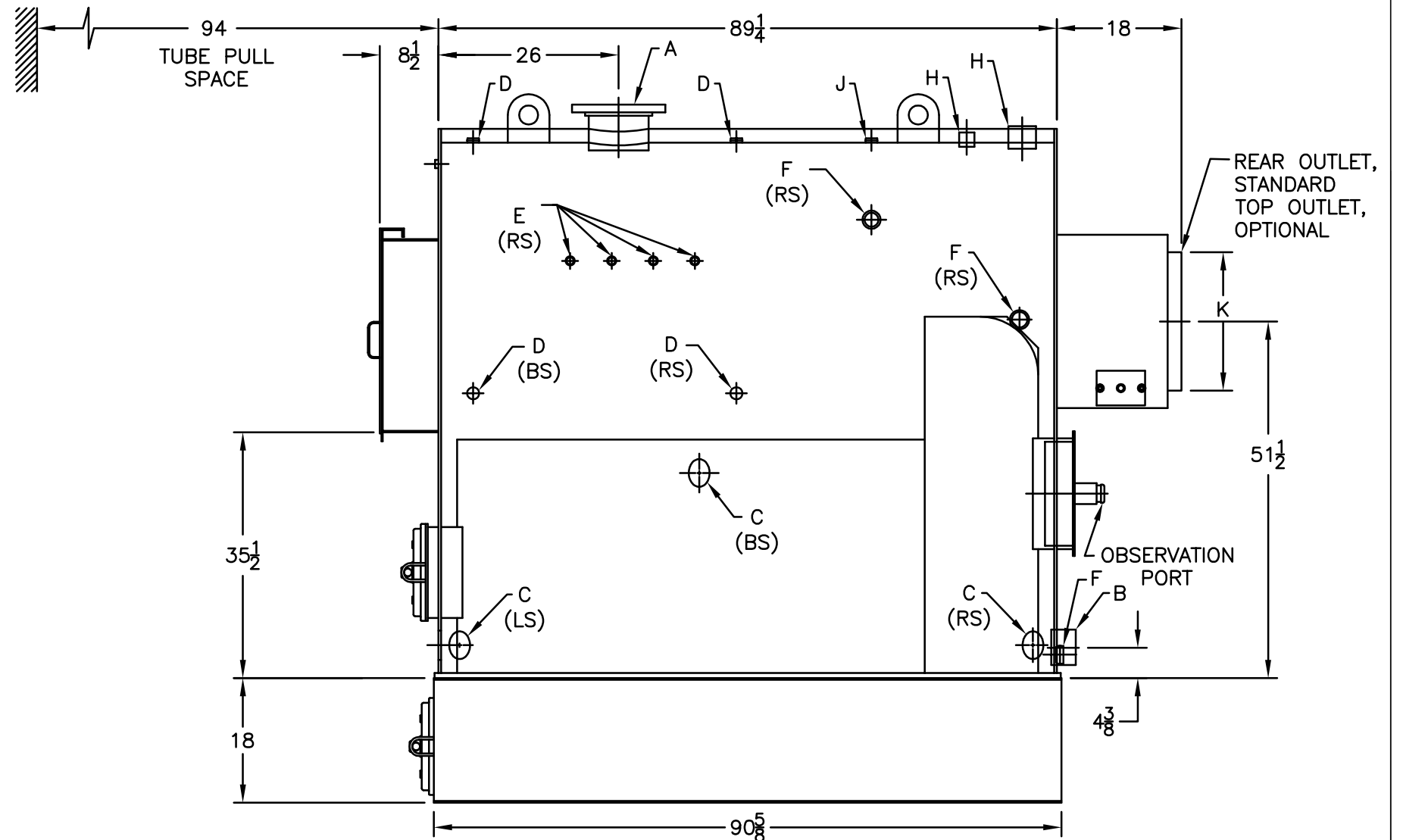
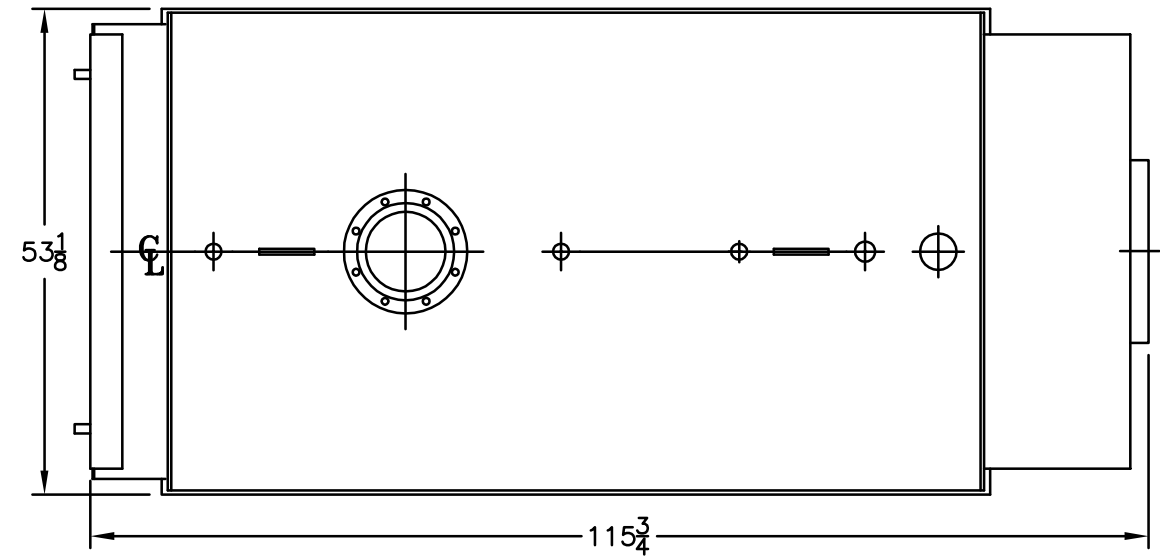
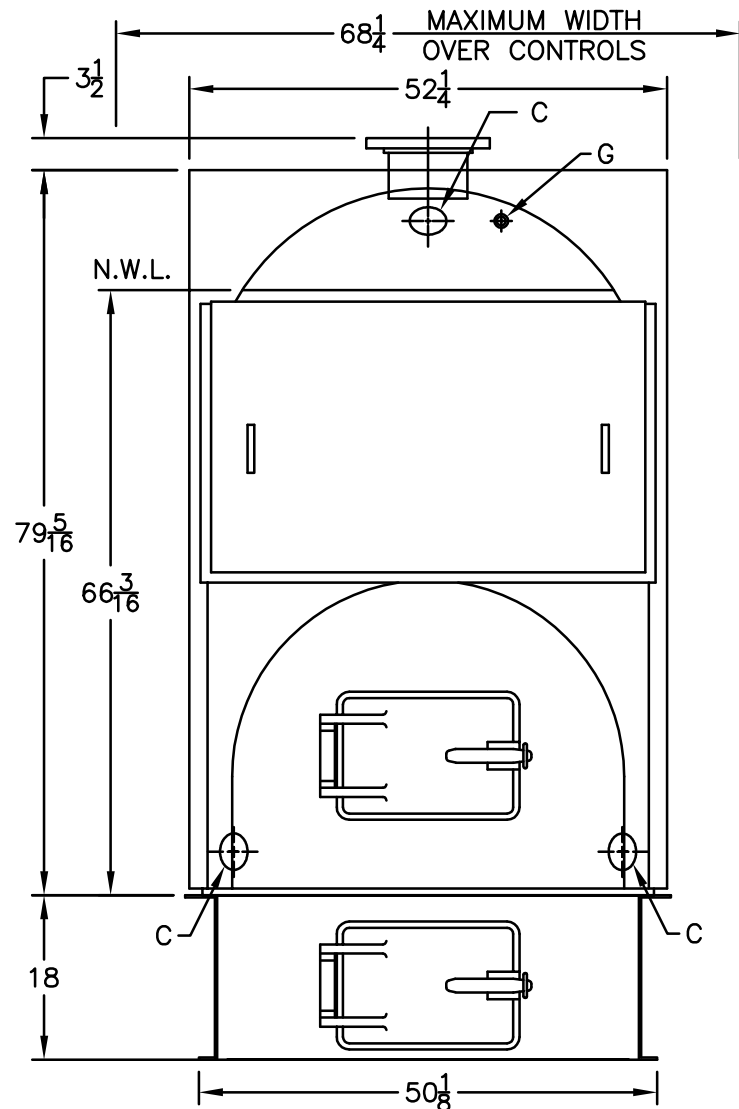

SPECIFICATIONS SUBJECT TO CHANGE WITHOUT NOTICE ALL CONNECTIONS ARE THREADED UNLESS OTHERWISE SPECIFIED
 THIS DOCUMENT CONTAINS CONFIDENTIAL INFORMATION WHICH IS THE PROPERTY OF BURNHAM COMMERCIAL. THIS DOCUMENT MAY NOT BE REPRODUCED, TRANSFERRED OR USED, OR ITS CONTENTS DISCLOSED, WITHOUT THE WRITTEN PERMISSION OF THE OWNER.

MODEL 4N-463A

NOV 2015 TS-3-58-2