

BURNHAM®

Commercial Boilers

LEGEND CONNECTIONS

- A = 10" FLANGED SUPPLY
- B = 4" RETURN
- C = 3" x 4" HANDHOLE
- D = 1" WATER COLUMN
- E = 3/4" AQUASTAT
- F = 1-1/2" SURFACE BLOWOFF/WASHOUT
- G = 1/2" TEMPERATURE GAUGE
- H = 1-1/2" RELIEF VALVE
- 3" RELIEF VALVE
- J = 1" AUXILIARY CONNECTION
- K = 28" NOMINAL FLUE DIAMETER

RATINGS AND DATA

Shell Diameter : 51 $\frac{3}{8}$ "

Heating Surface - Sq. Ft.
 Fireside - 662
 Waterside - 715

Firetubes
 Number - 82
 Diameter - 3" O.D.

Furnace
 Volume (Cubic Feet) - 105.3

Water Content
 Steam - 706 Gal. (U.S.)
 Water - 866 Gal. (U.S.)

Approximate Weight (Lb.)
 Dry - 10100
 Wet (Steam) - 15960
 Wet (Water) - 17320

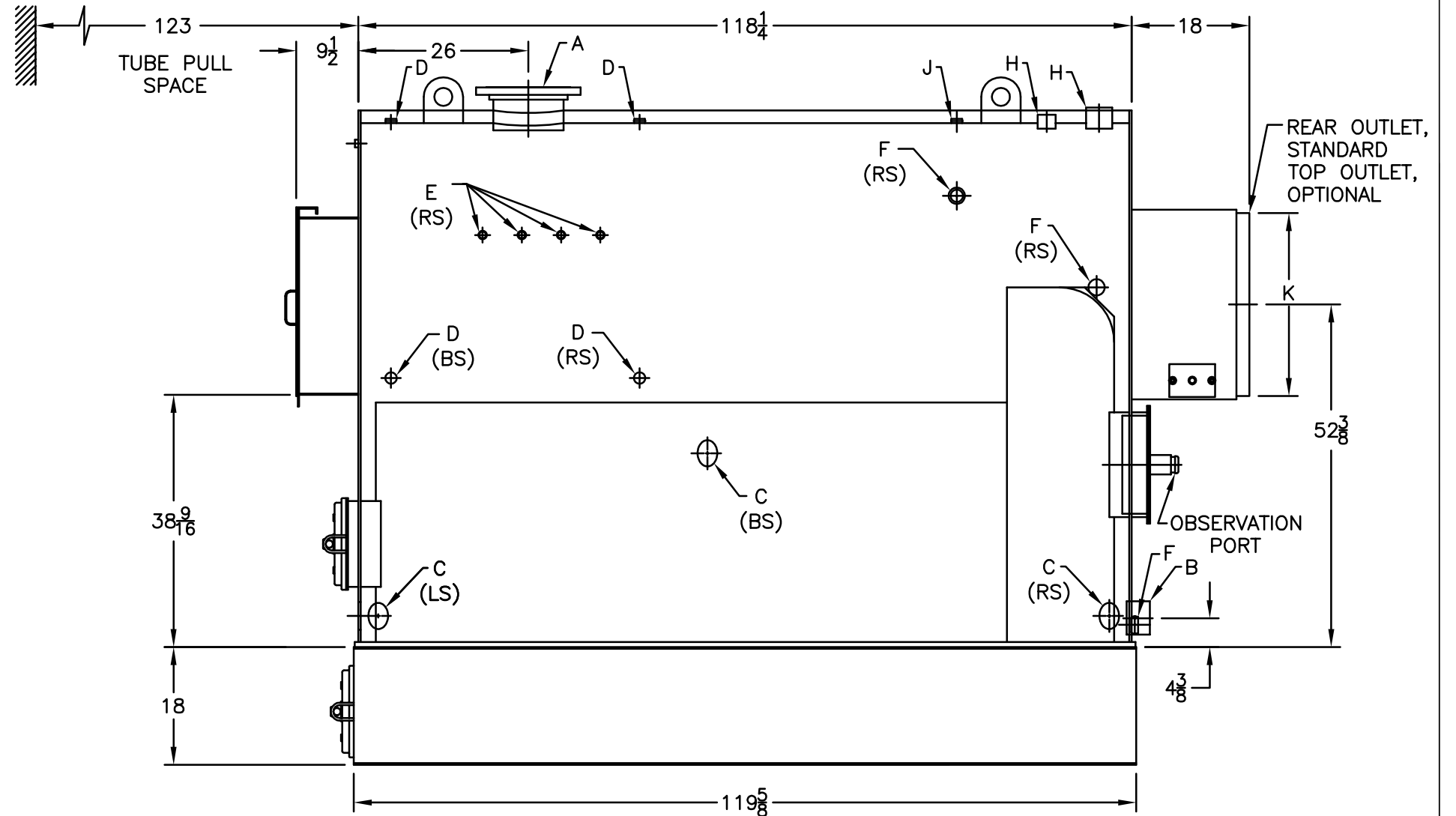
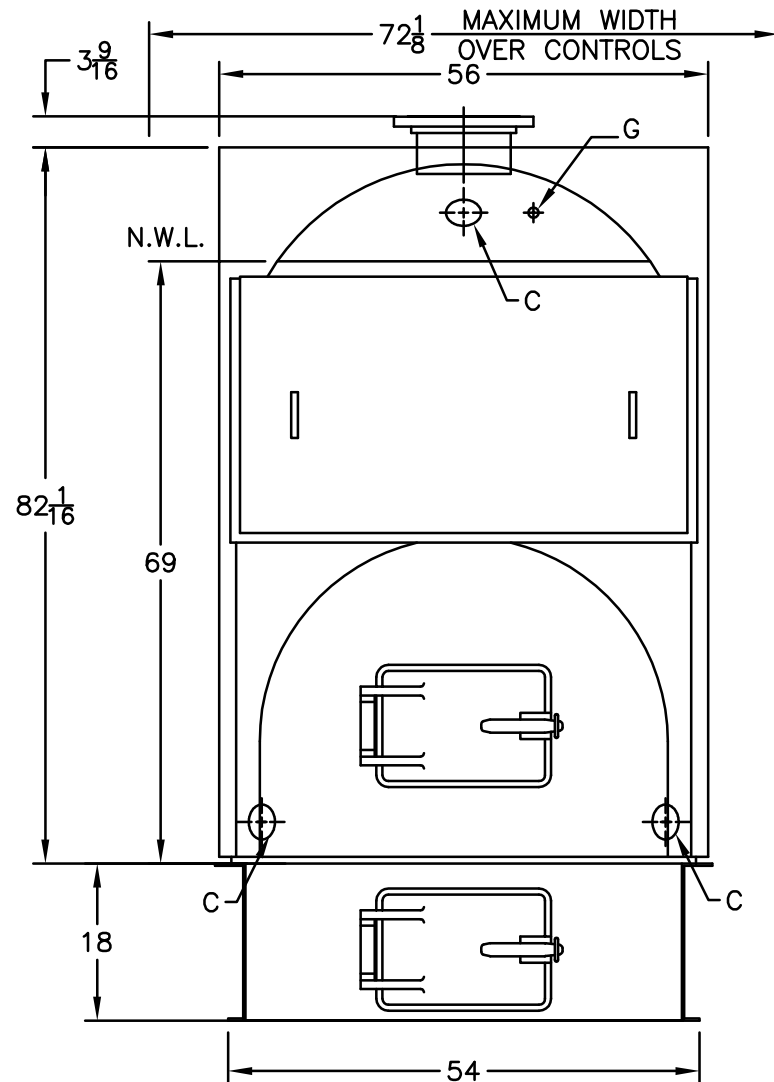
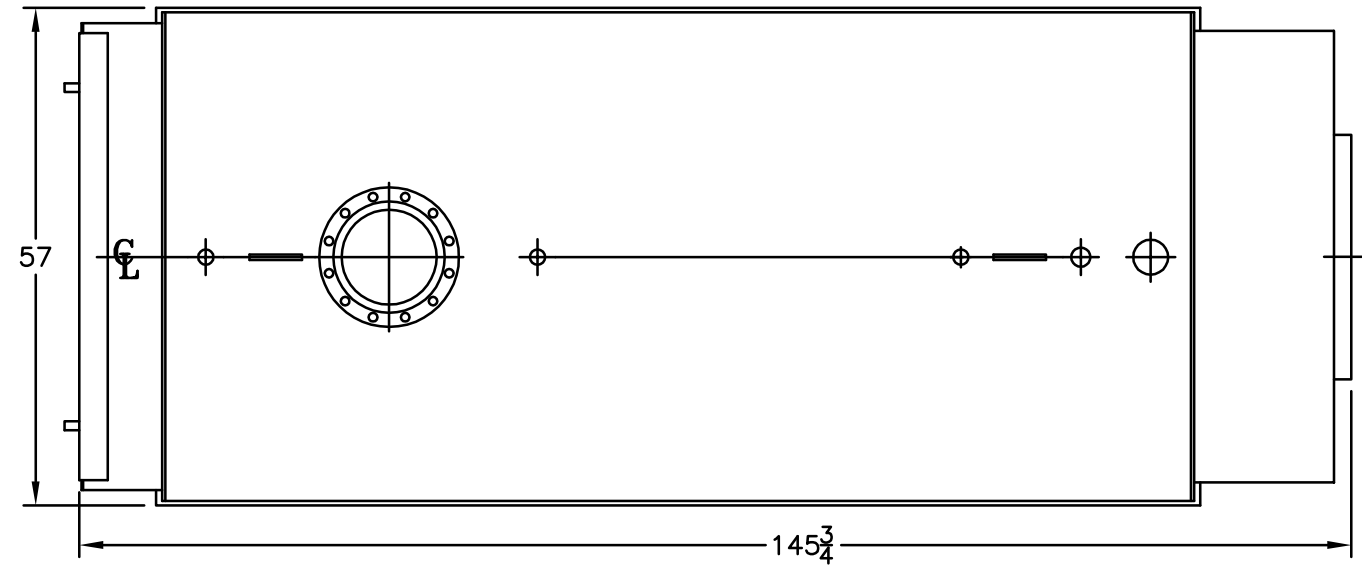

SPECIFICATIONS SUBJECT TO CHANGE WITHOUT NOTICE ALL CONNECTIONS ARE THREADED UNLESS OTHERWISE SPECIFIED
 THIS DOCUMENT CONTAINS CONFIDENTIAL INFORMATION WHICH IS THE PROPERTY OF BURNHAM COMMERCIAL. THIS DOCUMENT MAY NOT BE REPRODUCED, TRANSFERRED OR USED, OR ITS CONTENTS DISCLOSED, WITHOUT THE WRITTEN PERMISSION OF THE OWNER.

MODEL 4N-662A

NOV 2015 TS-3-60-2