

BURNHAM®

Commercial Boilers

RATINGS AND DATA

Shell Diameter : 45 $\frac{1}{4}$ "
 Gross Output - BHP : 178.6
 Gross Output - MBH : 5980
 Gross Output - Lbs/Hr. : 6163
 Safety Valve - Lbs/Hr. : 6437

LEGEND CONNECTIONS

- A = 8" FLANGED SUPPLY (300#)
- B = 4" RETURN
- C = 2" WASHOUT
- D = 1" WATER COLUMN
- E = 3/4" AQUASTAT
- F = 2" SURFACE BLOWOFF/BOTTOM BLOWDOWN
- G = 3 X 4 HANDHOLE
- H = 2" AUXILIARY CONNECTION
- J = 2" SAFETY VALVE (2)
1-1/2" SAFETY VALVE (1)
- K = 16" NOMINAL FLUE DIAMETER

Heating Surface - Sq. Ft.
 Fireside - 641
 Firetubes
 Number - 126
 Diameter - 2" O.D.

Firing Rate
 1000 BTU Gas (MBH) - 7144
 140000 BTU/Gal Oil (GPH) - 49.1

Water Content
 Pounds - 6631
 Gallons (U.S.) - 796
 Approximate Weight/LBS.
 Dry - 11413
 Wet - 18044

LEGEND

BS = BOTH SIDES
 RS = RIGHT SIDE

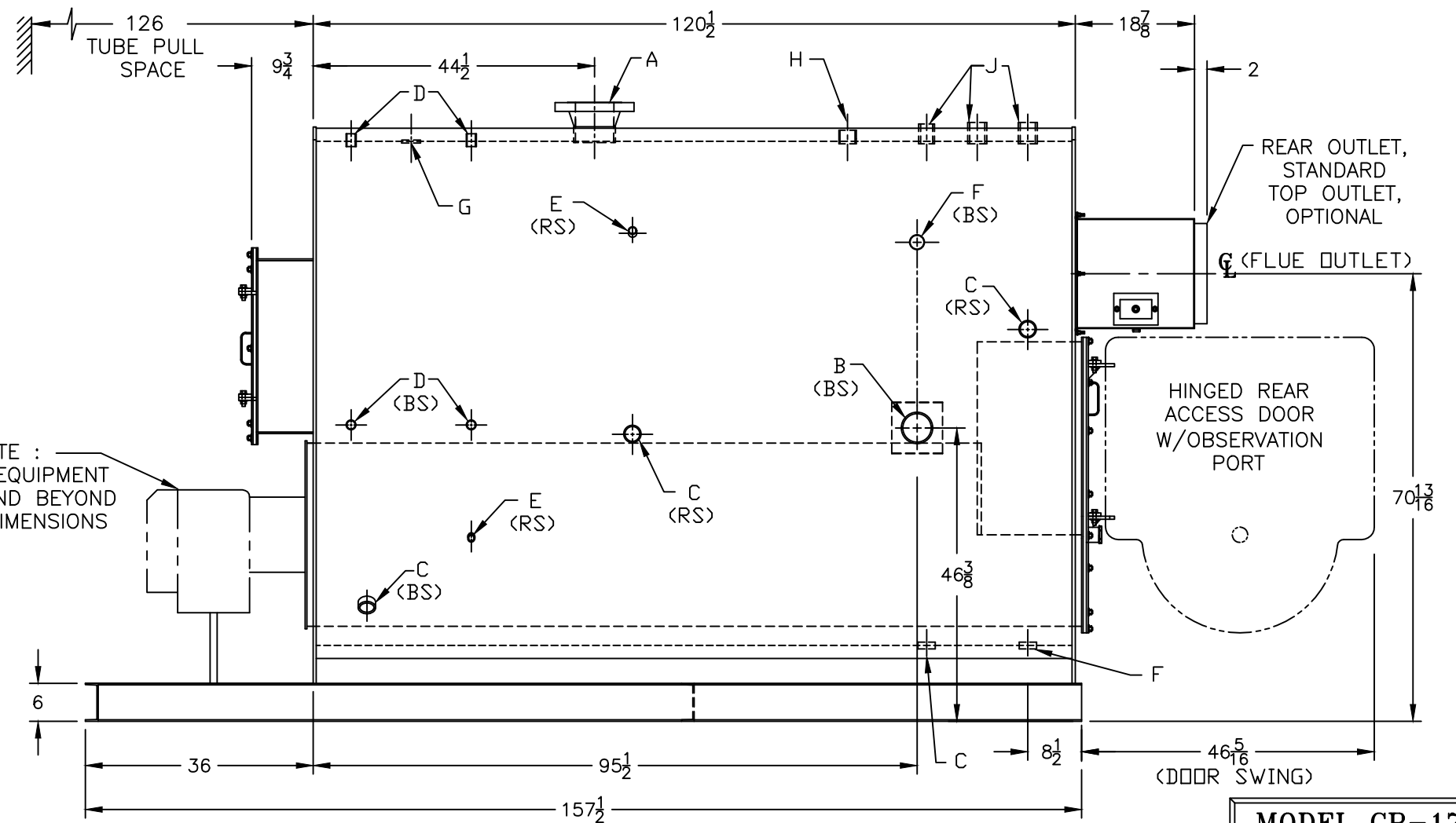
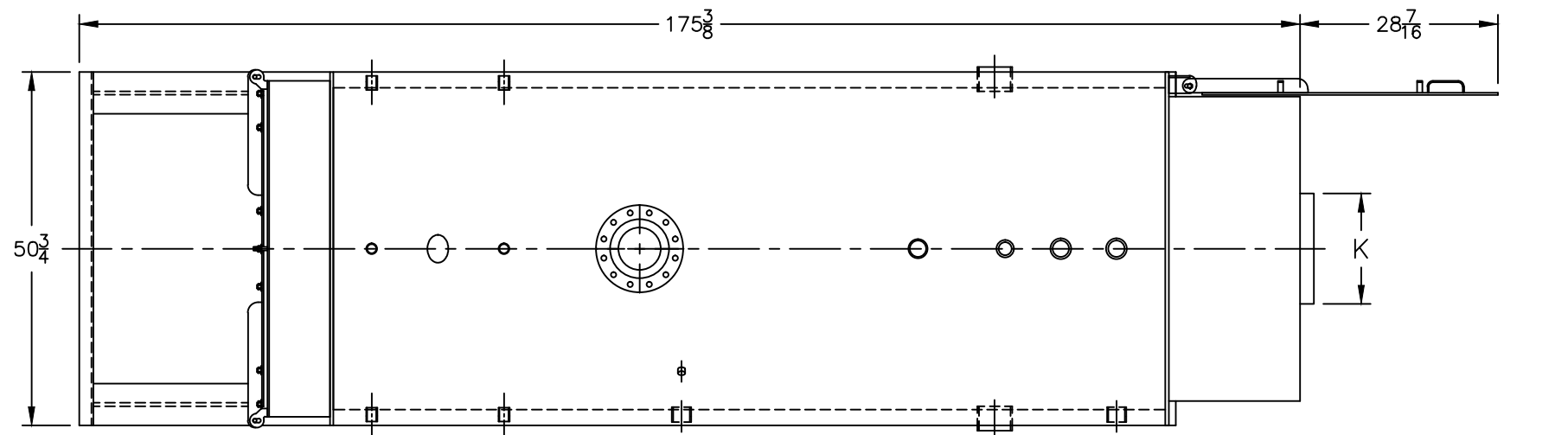
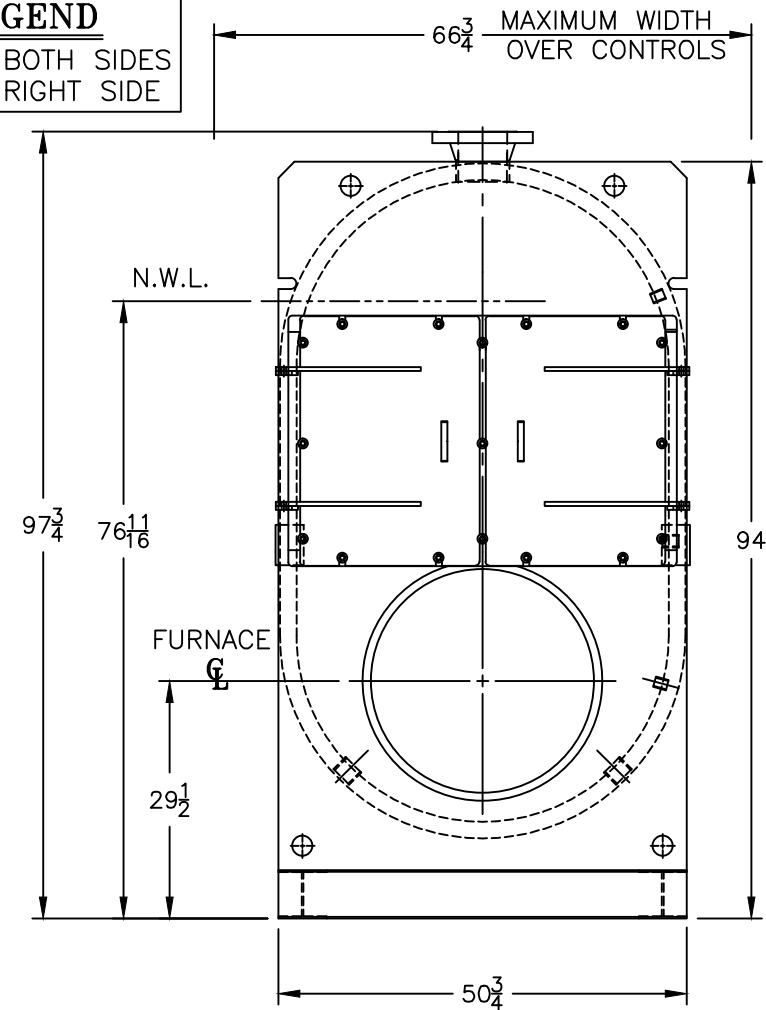

NOTE :
 BURNER EQUIPMENT
 MAY EXTEND BEYOND
 BOILER DIMENSIONS

MODEL CP-175A
178.6 BHP
30 PSI STEAM

SPECIFICATIONS SUBJECT TO CHANGE WITHOUT NOTICE ALL CONNECTIONS ARE THREADED UNLESS OTHERWISE SPECIFIED
 THIS DOCUMENT CONTAINS CONFIDENTIAL INFORMATION WHICH IS THE PROPERTY OF BURNHAM COMMERCIAL. THIS DOCUMENT MAY NOT BE REPRODUCED, TRANSFERRED OR USED, OR ITS CONTENTS DISCLOSED, WITHOUT THE WRITTEN PERMISSION OF THE OWNER.