

BURNHAM®

Commercial Boilers

RATINGS AND DATA

Shell Diameter : 45 $\frac{1}{4}$ "
 Gross Output - BHP : 154.5
 Gross Output - MBH : 5173
 Net Rating - MBH : 4498
 Safety Valve - MBH : 5173

Heating Surface - Sq. Ft.
 Fireside - 562
 Firetubes
 Number - 139
 Diameter - 2" O.D.

Firing Rate
 1000 BTU Gas (MBH) - 6123
 140000 BTU/Gal Oil (GPH) - 42.0

Water Content
 Pounds - 7256
 Gallons (U.S.) - 871
 Approximate Weight/LBS.
 Dry - 12034
 Wet - 19290

LEGEND CONNECTIONS

- A = 6" 150# FLANGED SUPPLY
- B = 6" 150# FLANGED RETURN
- C = 2" WASHOUT
- D = 1" WATER COLUMN
- E = 3/4" AQUASTAT
- F = 2" DRAIN
- G = 3 X 4 HANDHOLE
- H = 2" AUXILIARY CONNECTION
- J = 2" SAFETY/RELIEF VALVE (1)
1" SAFETY/RELIEF VALVE (1)
- K = 3/4" TEMPERATURE GAUGE
- M = 16" NOMINAL FLUE DIAMETER

LEGEND

- BS = BOTH SIDES
- RS = RIGHT SIDE

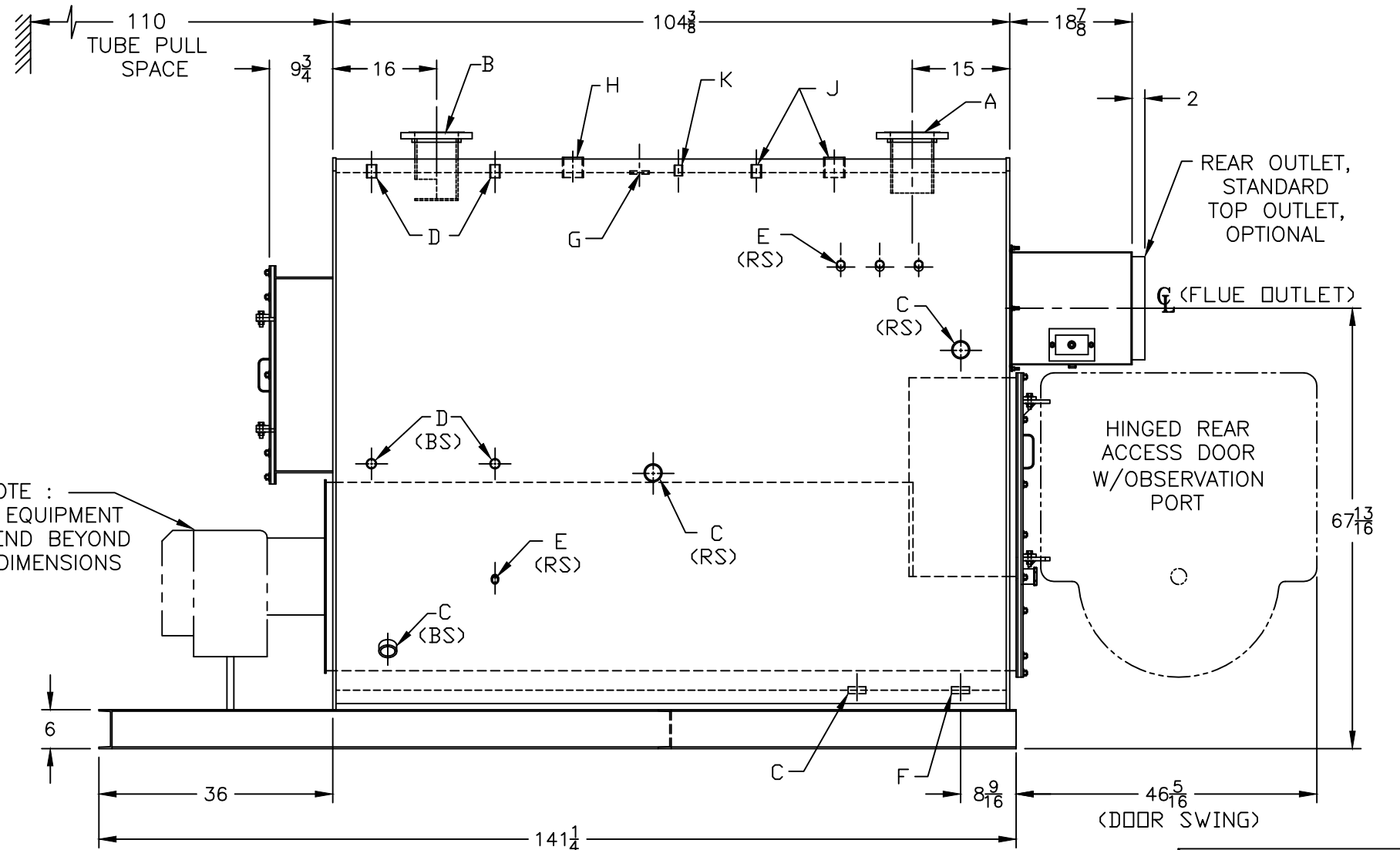
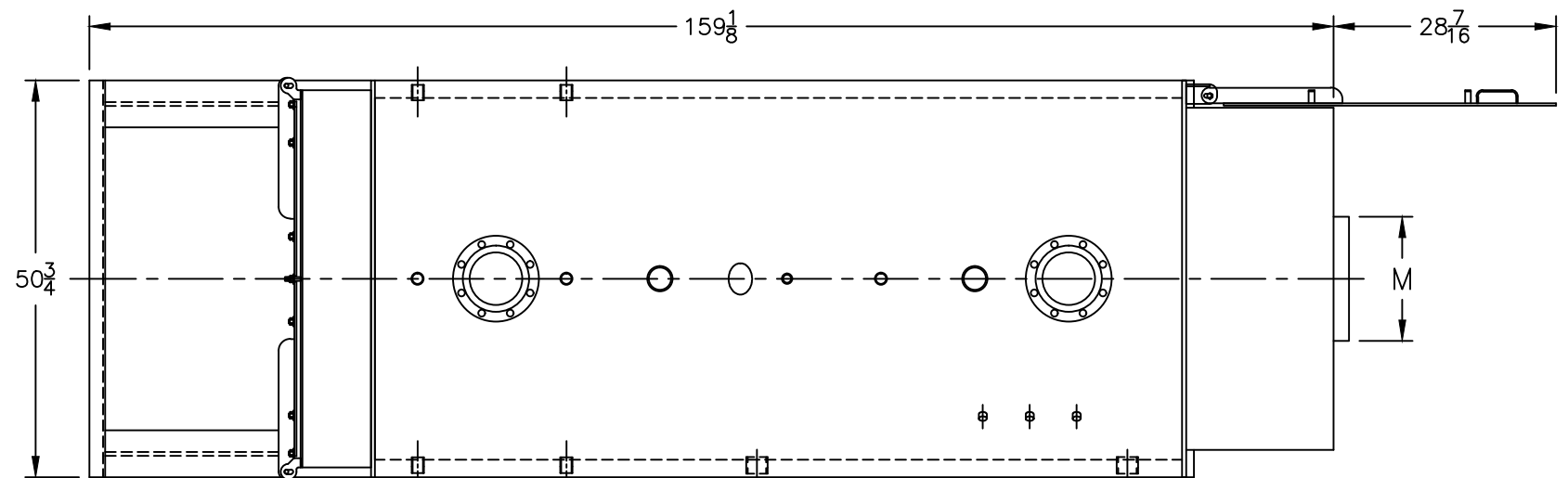
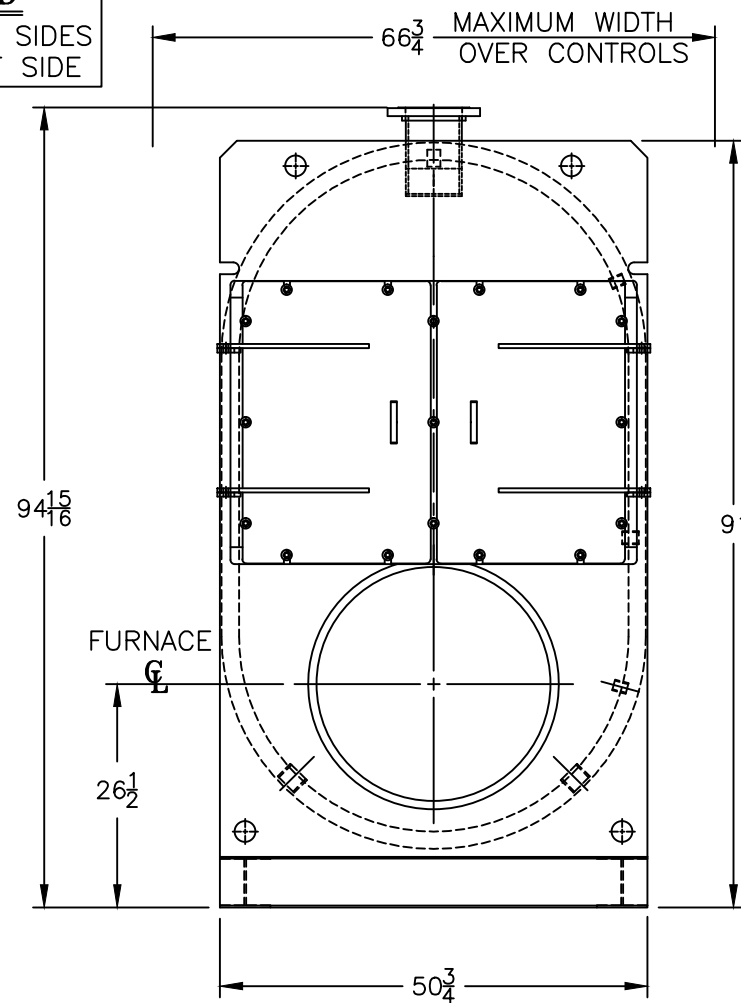

MODEL CPW-150A
154.5 BHP
60 PSI WATER

SPECIFICATIONS SUBJECT TO CHANGE WITHOUT NOTICE ALL CONNECTIONS ARE THREADED UNLESS OTHERWISE SPECIFIED
 THIS DOCUMENT CONTAINS CONFIDENTIAL INFORMATION WHICH IS THE PROPERTY OF BURNHAM COMMERCIAL. THIS DOCUMENT MAY NOT BE REPRODUCED, TRANSFERRED OR USED, OR ITS CONTENTS DISCLOSED, WITHOUT THE WRITTEN PERMISSION OF THE OWNER.