

BURNHAM®

Commercial Boilers

LEGEND CONNECTIONS

- A = 18" FLANGED SUPPLY (150#)
- B = 4" RETURN
- C = 3" x 4" HANDHOLE
- D = 1" WATER COLUMN
- E = 3/4" AQUASTAT
- F = 2" BOTTOM BLOWDOWN
- G = 2" SURFACE BLOWOFF
- H = 2" AUXILIARY CONNECTION
- J = 3" SAFETY VALVE (4)
2-1/2" SAFETY VALVE (1)
- K = 12" x 16" MANHOLE
- L = 34" NOMINAL FLUE DIAMETER

RATINGS AND DATA

Shell Diameter : 108"
 Gross Output - BHP : 800
 Gross Output - MBH : 26780
 Gross Output - Lbs/Hr : 27600
 Net Rating - MBH : 20792
 Net Rating - Sq. Ft. : 86633
 Safety Valve - Lbs/Hr. : 32000

Heating Surface - Sq. Ft.
 Fireside - 4000
 Firetubes
 Number - 338
 Diameter - 2.5" O.D.

Firing Rate
 1000 BTU Gas (MBH) - 33475
 140000 BTU/Gal Oil (GPH) - 239.1
 150000 BTU/Gal Oil (GPH) - 223.2

Water Content
 Pounds - 33000
 Gallons (U.S.) - 3956
 Approximate Weight/LBS.
 Dry - 43900
 Wet - 76900

LEGEND

BS = BOTH SIDES
 RS = RIGHT SIDE

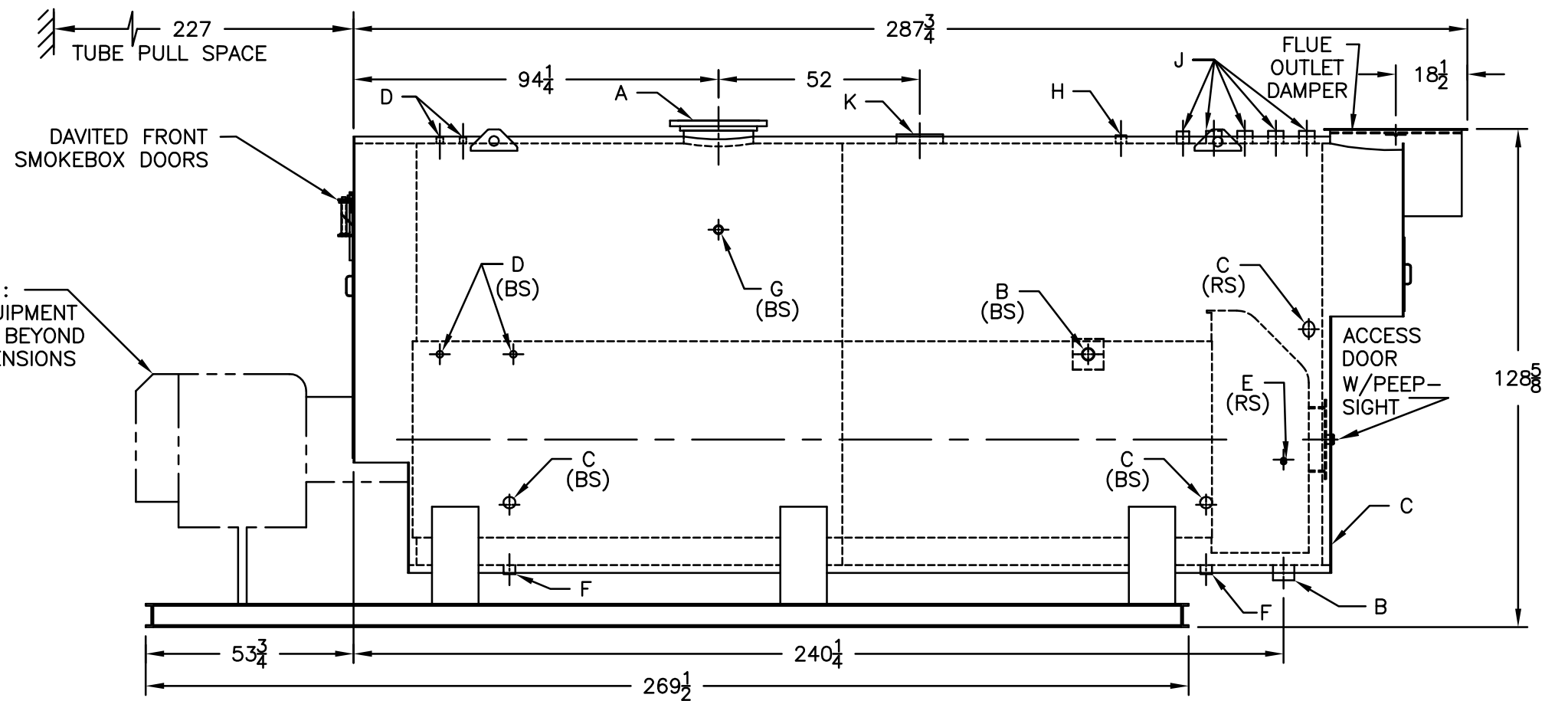
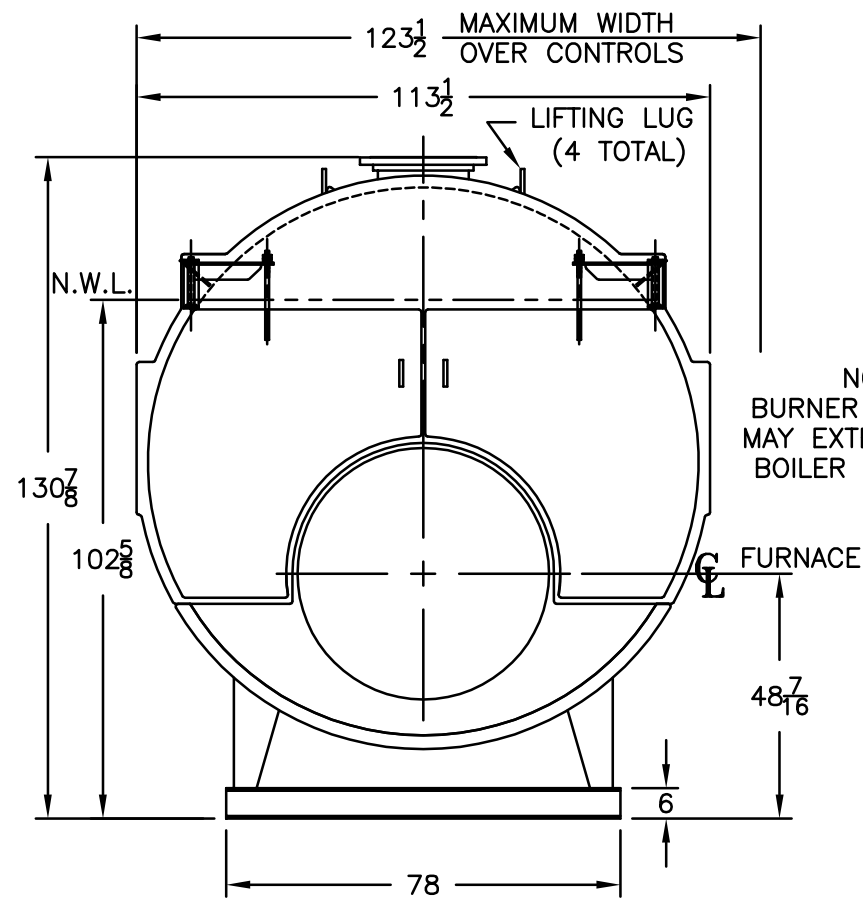
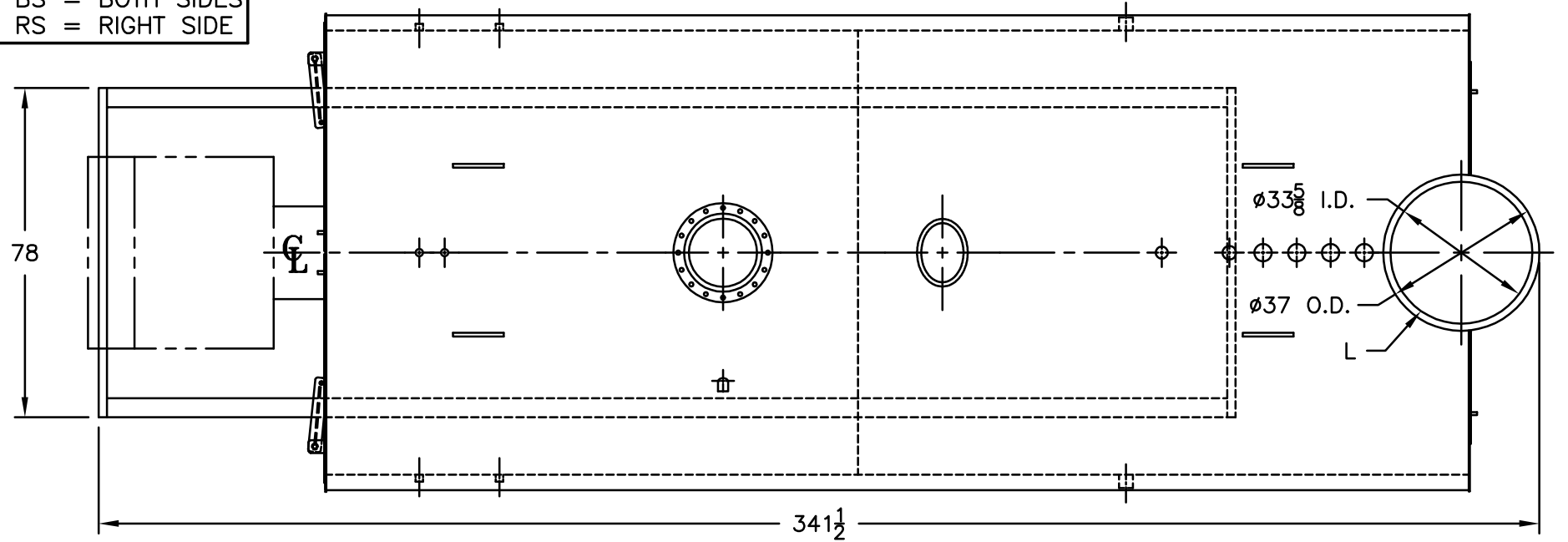

SPECIFICATIONS SUBJECT TO CHANGE WITHOUT NOTICE ALL CONNECTIONS ARE THREADED UNLESS OTHERWISE SPECIFIED
 THIS DOCUMENT CONTAINS CONFIDENTIAL INFORMATION WHICH IS THE PROPERTY OF BURNHAM COMMERCIAL. THIS DOCUMENT MAY NOT BE REPRODUCED, TRANSFERRED OR USED, OR ITS CONTENTS DISCLOSED, WITHOUT THE WRITTEN PERMISSION OF THE OWNER.

MODEL 3L-800
800 BHP
15 PSI STEAM