

BURNHAM®

Commercial Boilers

RATINGS AND DATA

Shell Diameter : 48"
 Gross Output - BHP : 41.1
 Gross Output - MBH : 1374
 Net Rating - MBH : 1195
 Relief Valve - MBH : 1600

Heating Surface - Sq. Ft.
 Fireside - 200

Firetubes
 Number - 92
 Diameter - 2" O.D.

Firing Rate
 1000 BTU Gas (MBH) - 1674
 140000 BTU/Gal Oil (GPH) - 11.7
 150000 BTU/Gal Oil (GPH) - 10.9

Water Content
 Pounds - 2167
 Gallons (U.S.) - 260
 Approximate Weight/LBS.
 Dry - 3920
 Wet - 6087

LEGEND

BS = BOTH SIDES
 RS = RIGHT SIDE

LEGEND CONNECTIONS

- A = 4" SUPPLY
- B = 4" RETURN
- C = 3" x 4" HANDHOLE
- D = 1" WATER COLUMN
- E = 3/4" AQUASTAT/LFHA
- F = 1-1/2" BOTTOM BLOWDOWN
- G = 1-1/2" EXPANSION TANK
- H = 3/4" TEMPERATURE GAUGE
- J = 1-1/4" SAFETY/RELIEF VALVE
- K = 10" NOMINAL FLUE DIAMETER

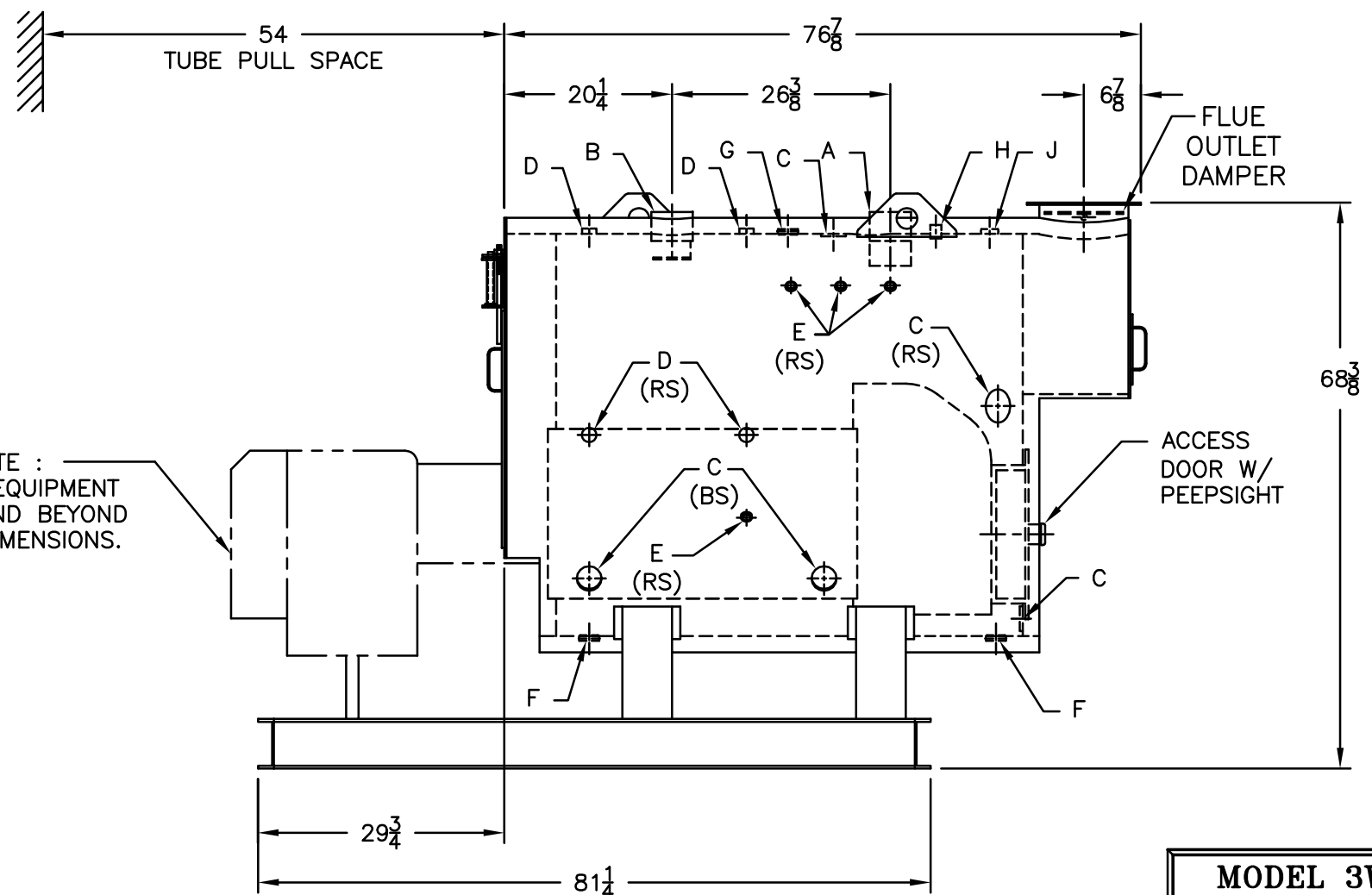
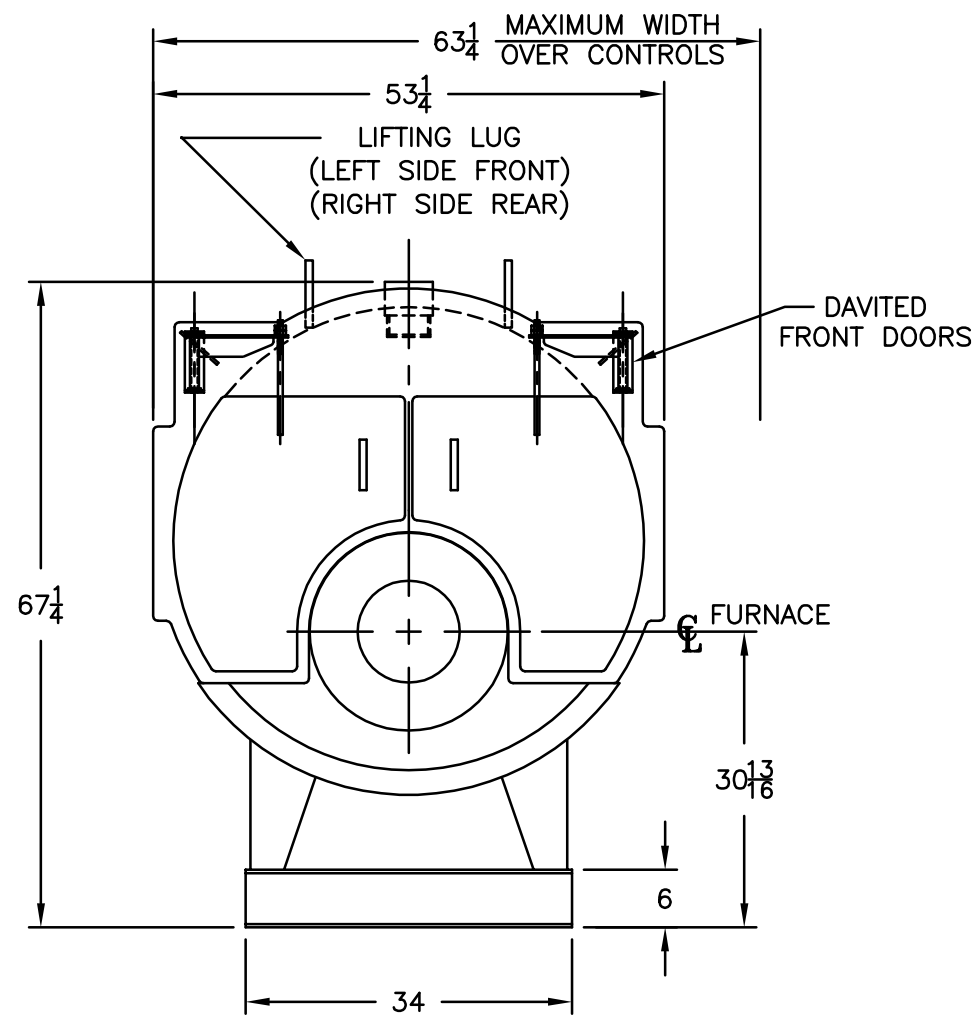
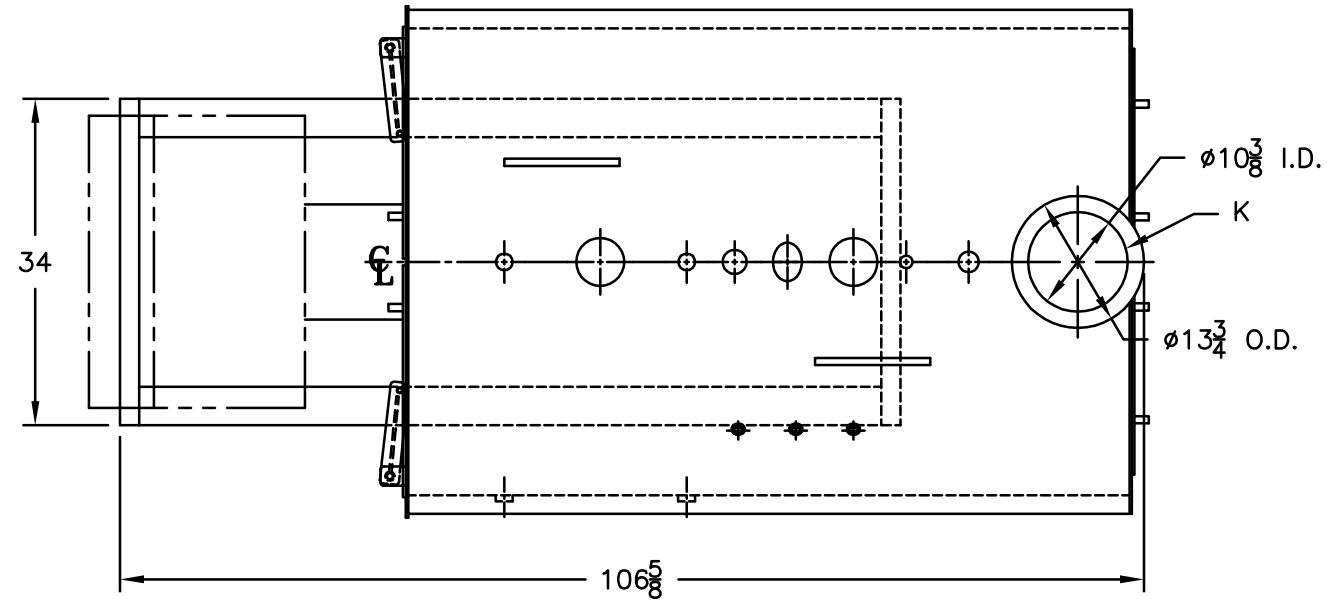

NOTE :
 BURNER EQUIPMENT
 MAY EXTEND BEYOND
 BOILER DIMENSIONS.

MODEL 3W-40
41.1 BHP
30 PSI WATER