

# BURNHAM®

## Commercial Boilers

### LEGEND CONNECTIONS

- A = 4" SUPPLY
- B = 4" RETURN
- C = 3" x 4" HANDHOLE
- D = 1" WATER COLUMN
- E = 3/4" AQUASTAT/LFHA
- F = 1-1/2" BOTTOM BLOWDOWN
- G = 1-1/2" EXPANSION TANK
- H = 3/4" TEMPERATURE GAUGE
- J = 1-1/4" SAFETY/RELIEF VALVE
- K = 10" NOMINAL FLUE DIAMETER

### RATINGS AND DATA

Shell Diameter : 48"  
 Gross Output - BHP : 51.6  
 Gross Output - MBH : 1728  
 Net Rating - MBH : 1503  
 Relief Valve - MBH : 2000

---

Heating Surface - Sq. Ft.  
 Fireside - 250

---

Firtubes  
 Number - 92  
 Diameter - 2" O.D.

---

Firing Rate  
 1000 BTU Gas (MBH) - 2092  
 140000 BTU/Gal Oil (GPH) - 14.5  
 150000 BTU/Gal Oil (GPH) - 13.5

---

Water Content  
 Pounds - 2693  
 Gallons (U.S.) - 323  
 Approximate Weight/LBS.  
 Dry - 4380  
 Wet - 7073

### LEGEND

BS = BOTH SIDES  
 RS = RIGHT SIDE

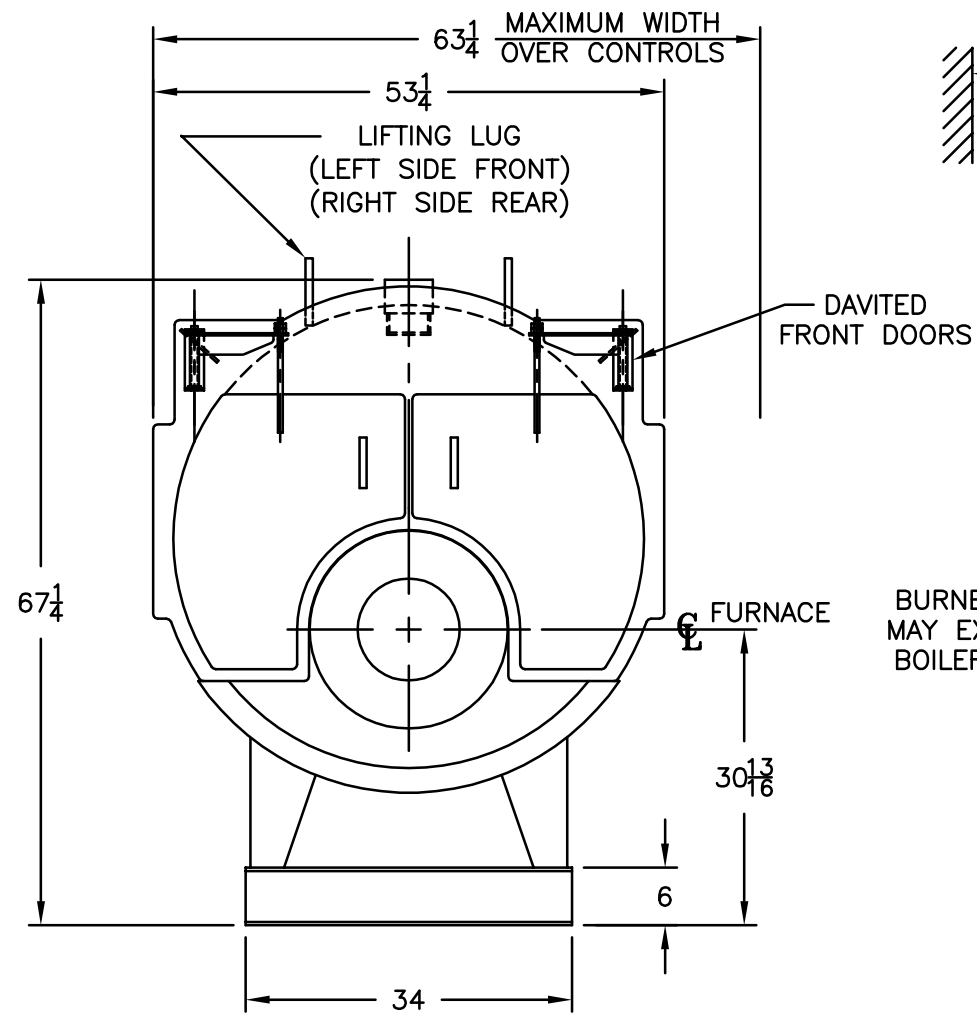
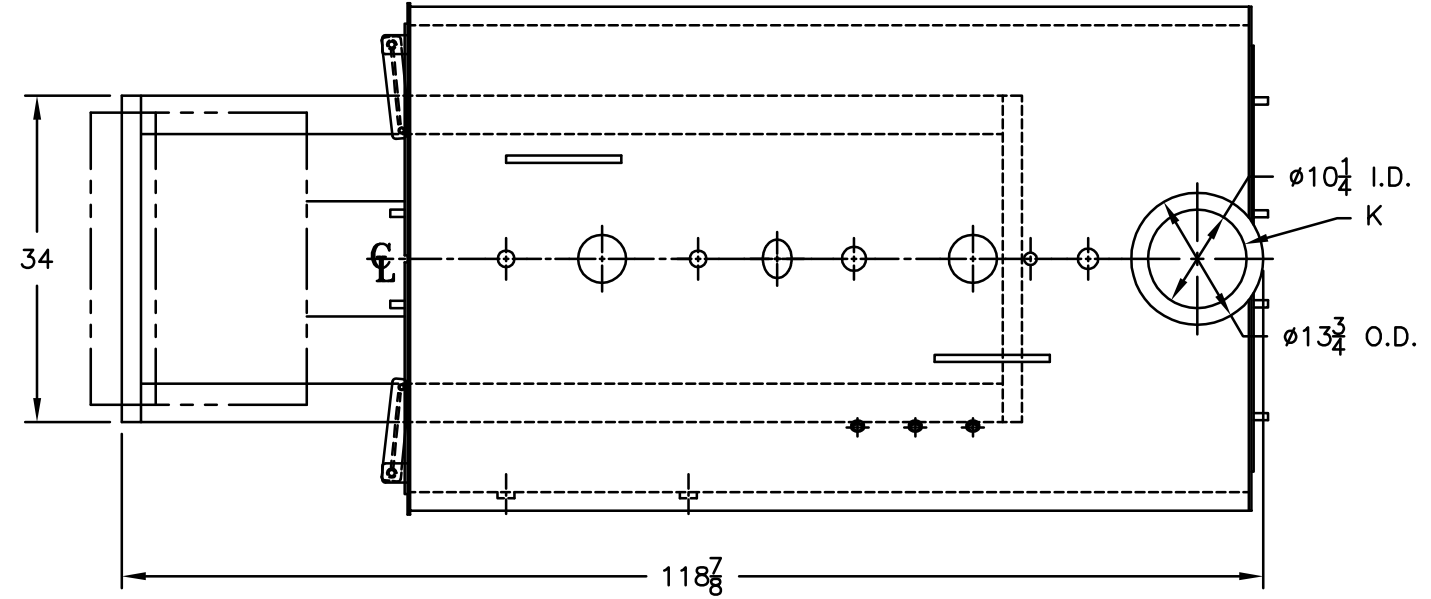

NOTE :  
 BURNER EQUIPMENT  
 MAY EXTEND BEYOND  
 BOILER DIMENSIONS.

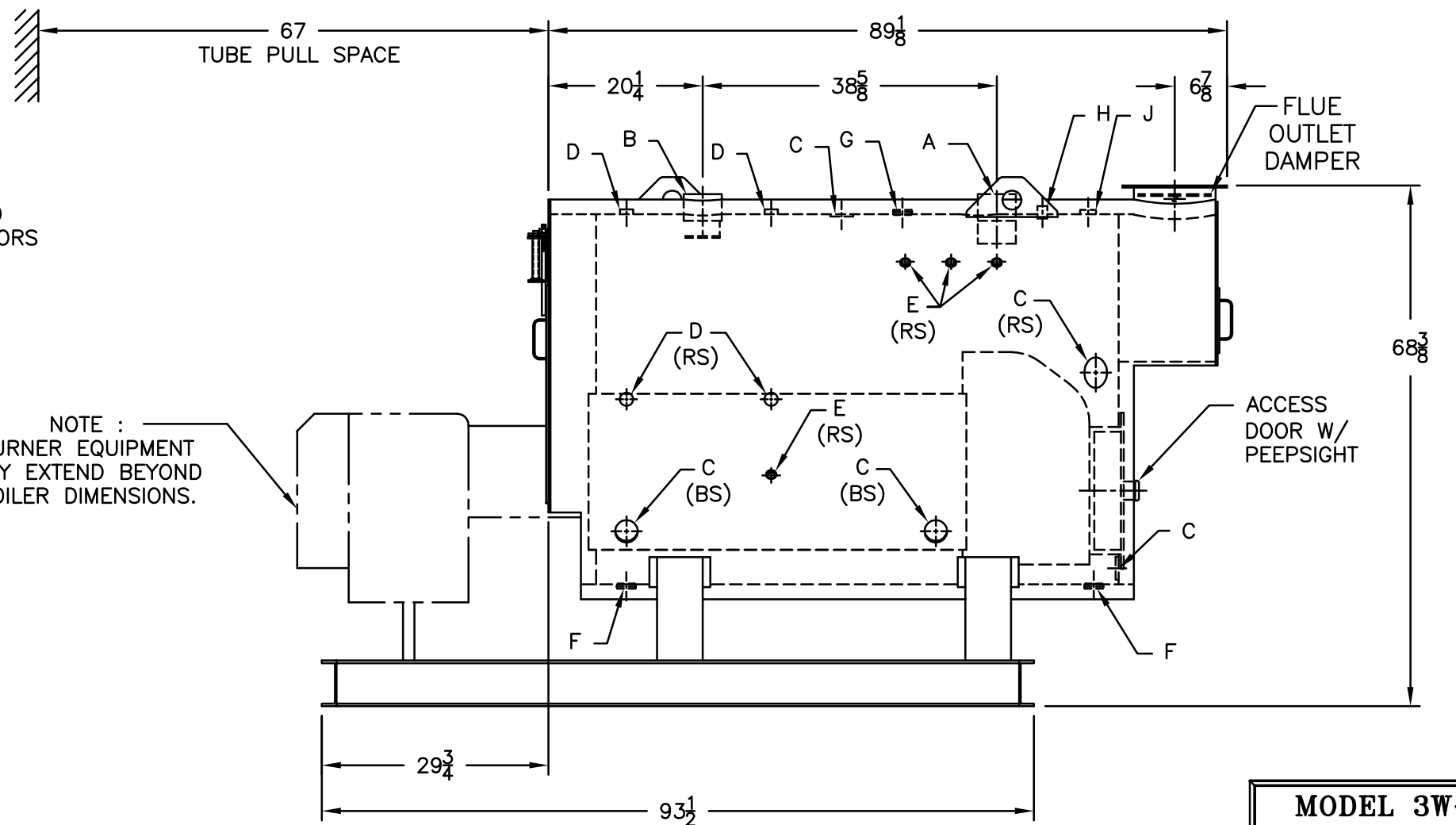

**MODEL 3W-50**  
**51.6 BHP**  
**30 PSI WATER**