

# BURNHAM®

## Commercial Boilers

### RATINGS AND DATA

Shell Diameter : 54"  
 Gross Output - BHP : 82.8  
 Gross Output - MBH : 2772  
 Net Rating - MBH : 2411  
 Relief Valve - MBH : 3200

---

Heating Surface - Sq. Ft.  
 Fireside - 400

---

Firetubes  
 Number - 106  
 Diameter - 2" O.D.

---

Firing Rate  
 1000 BTU Gas (MBH) - 3348  
 140000 BTU/Gal Oil (GPH) - 23.0  
 150000 BTU/Gal Oil (GPH) - 21.5

---

Water Content  
 Pounds - 4647  
 Gallons (U.S.) - 557  
 Approximate Weight/LBS.  
 Dry - 5900  
 Wet - 10547

### LEGEND

BS = BOTH SIDES  
 RS = RIGHT SIDE

### LEGEND CONNECTIONS

- A = 4" SUPPLY
- B = 4" RETURN
- C = 3" x 4" HANDHOLE
- D = 1" WATER COLUMN
- E = 3/4" AQUASTAT
- F = 1-1/2" BOTTOM BLOWDOWN
- G = 1-1/2" EXPANSION TANK
- H = 3/4" TEMPERATURE GAUGE
- J = 2" SAFETY/RELIEF VALVE
- K = 12" NOMINAL FLUE DIAMETER

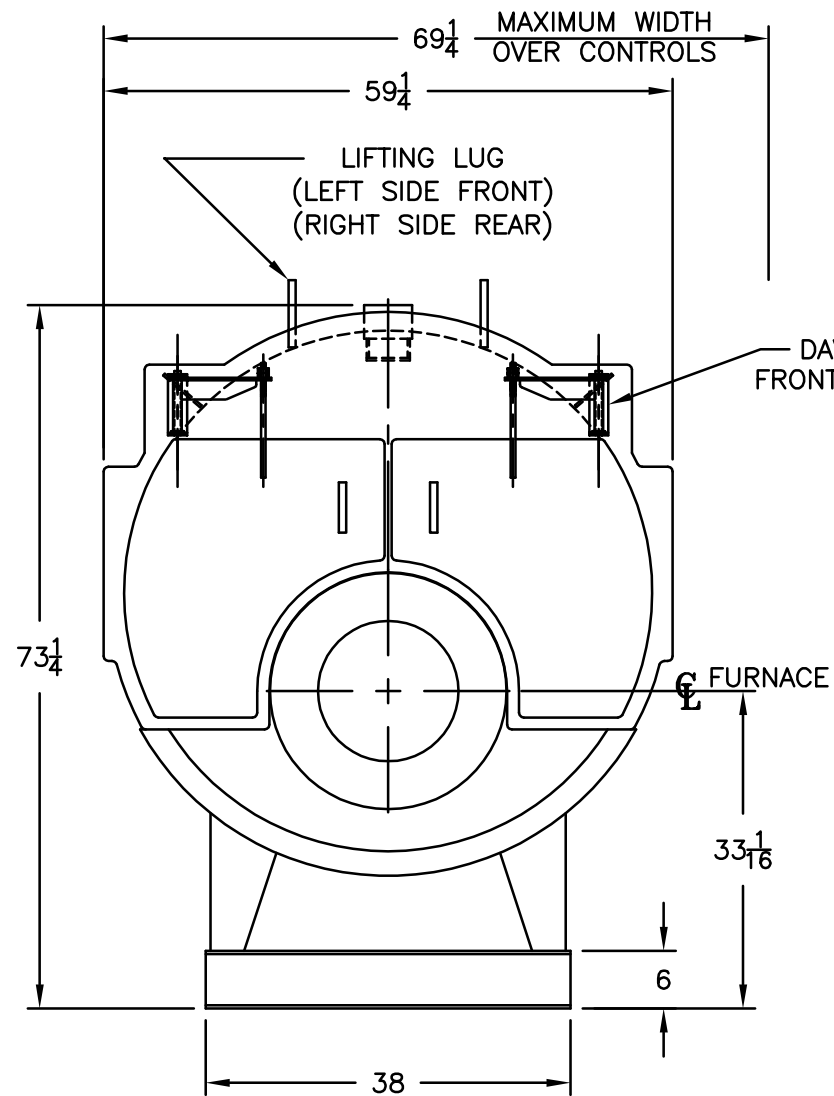
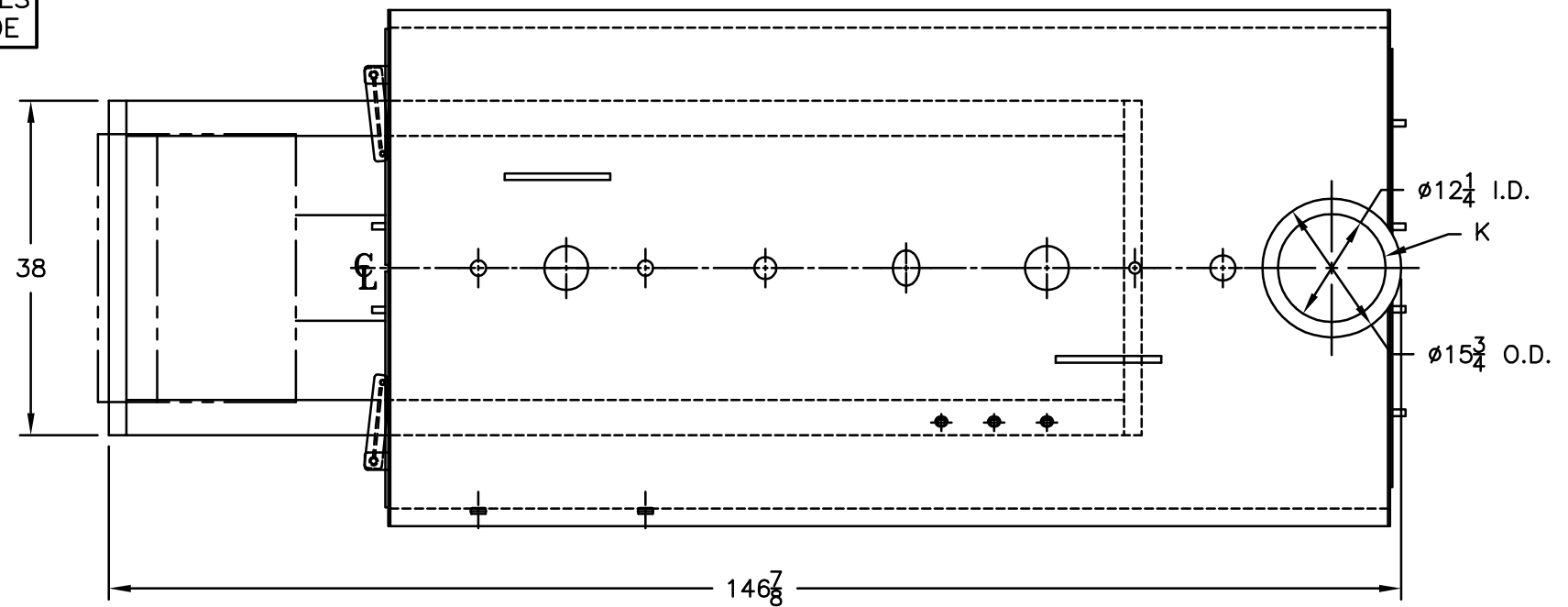

NOTE :  
 BURNER EQUIPMENT  
 MAY EXTEND BEYOND  
 BOILER DIMENSIONS.

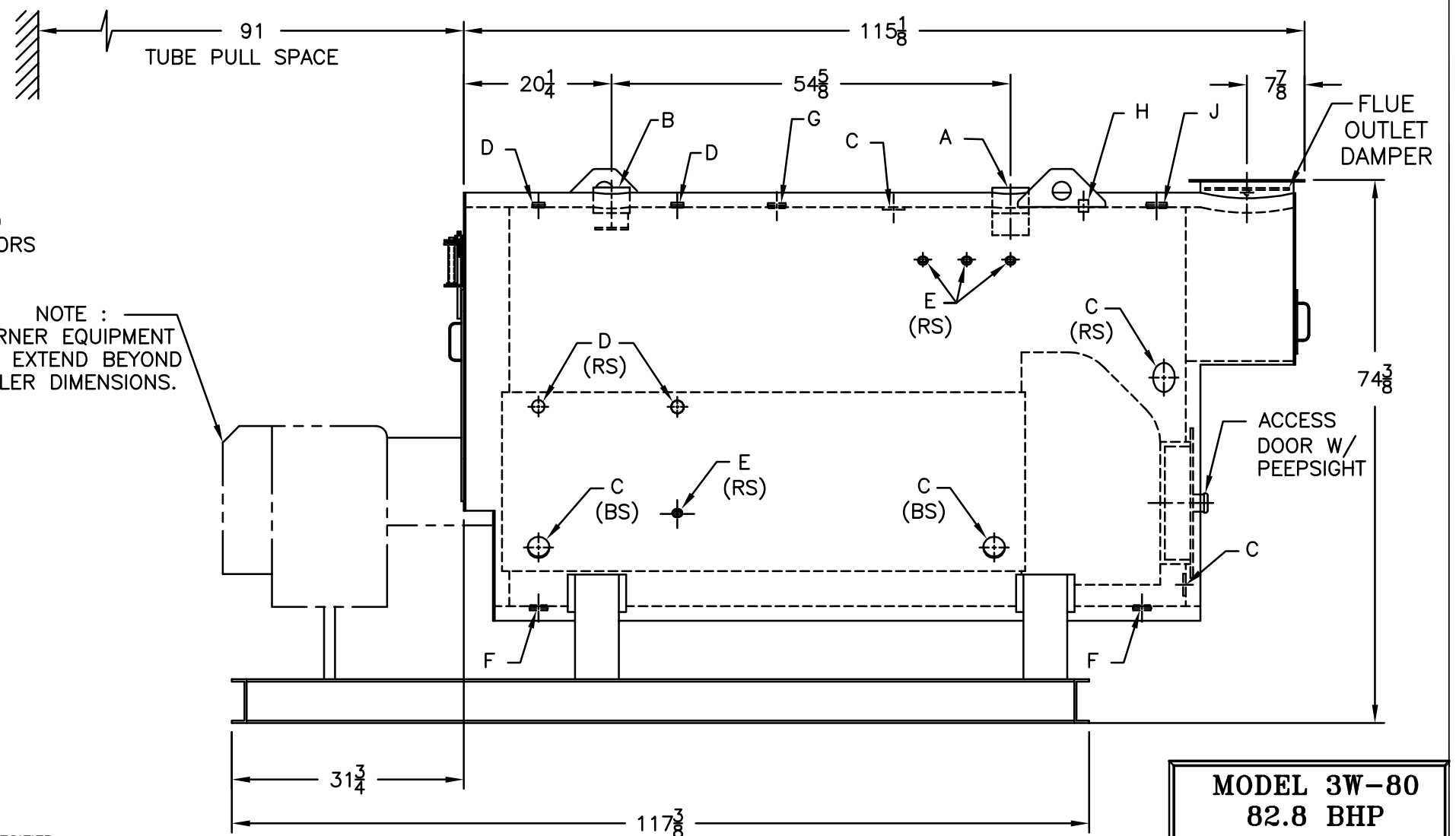

**MODEL 3W-80**  
**82.8 BHP**  
**30 PSI WATER**

SPECIFICATIONS SUBJECT TO CHANGE WITHOUT NOTICE ALL CONNECTIONS ARE THREADED UNLESS OTHERWISE SPECIFIED  
 THIS DOCUMENT CONTAINS CONFIDENTIAL INFORMATION WHICH IS THE PROPERTY OF BURNHAM COMMERCIAL. THIS DOCUMENT MAY NOT BE REPRODUCED, TRANSFERRED OR USED, OR ITS CONTENTS DISCLOSED, WITHOUT THE WRITTEN PERMISSION OF THE OWNER.