

BURNHAM®

Commercial Boilers

RATINGS AND DATA

Shell Diameter : 60"

Heating Surface - Sq. Ft.
 Fireside - 1157
 Waterside - 1250

Firetubes
 Number - 162
 Diameter - 2½" O.D.

Furnace
 Volume (Cubic Feet) -

Water Content
 Water -

Approximate Weight (Lb.)
 Dry -
 Wet -

LEGEND CONNECTIONS

- A = 6" FLANGED SUPPLY
- B = 6" FLANGED RETURN
- C = INSP./3" x 4" HANDHOLE
- D = 1" WATER COLUMN
- E = ¾" AQUASTAT
- F = 2" DRAIN
- G = ¾" TEMPERATURE GAUGE
- H = 2" EXPANSION TANK
- J = 2" RELIEF VALVE (1)
- K = ¾" RELIEF VALVE (1)
- L = 22" NOMINAL FLUE DIAMETER

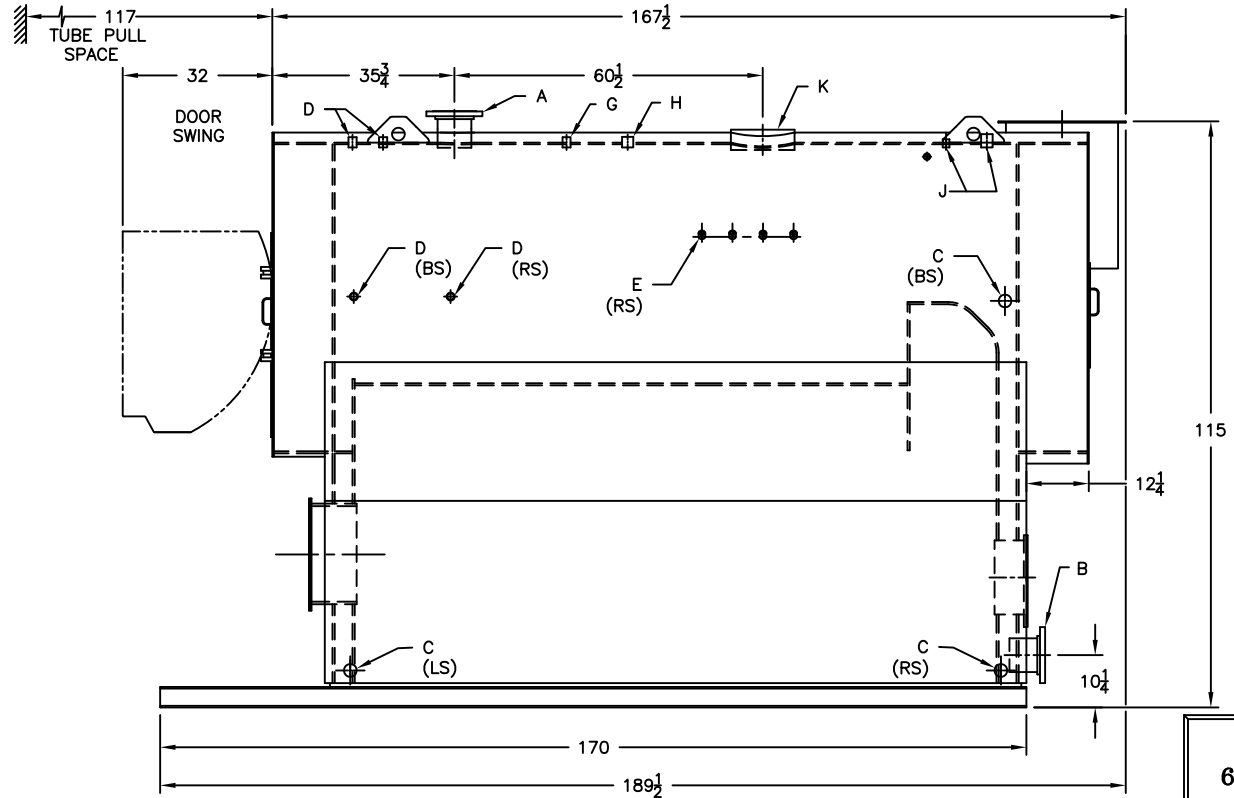
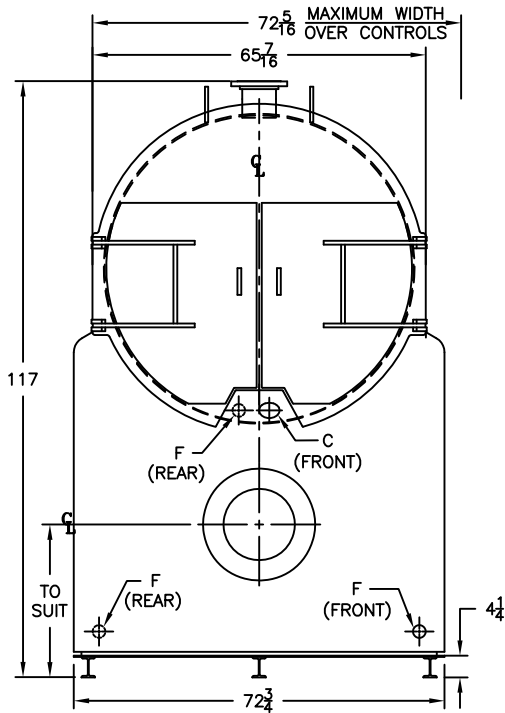
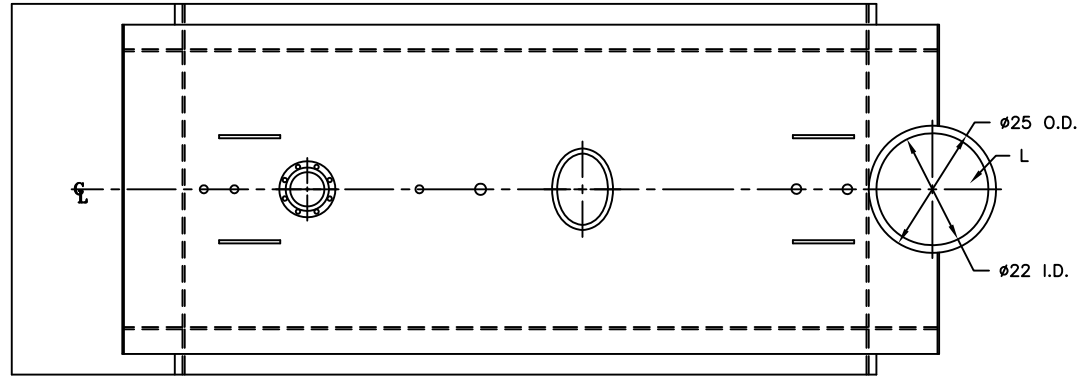

SPECIFICATIONS SUBJECT TO CHANGE WITHOUT NOTICE
 ALL CONNECTIONS ARE THREADED UNLESS OTHERWISE SPECIFIED

4FPW-1157
60 PSI WATER