

BURNHAM®

Commercial Boilers

LEGEND CONNECTIONS

- A = 3" SUPPLY
- B = 3" RETURN
- C = 3" x 4" HANDHOLE
- D = 1" WATER COLUMN
- E = 3/4" AQUASTAT
- F = 1-1/2" DRAIN/WASHOUT
- G = 1/2" TEMPERATURE GAUGE
- H = 3/4" SAFETY/RELIEF VALVE
- J = 1" AUXILIARY CONNECTION
- K = 7" NOMINAL FLUE DIAMETER

RATINGS AND DATA

Shell Diameter : 27 $\frac{1}{2}$ "

Heating Surface - Sq. Ft.
 Fireside - 59
 Waterside - 63

Firetubes
 Number - 41
 Diameter - 2" O.D.

Furnace
 Volume (Cubic Feet) - 9.2

Water
 Content - 82 Gal. (U.S.)

Approximate Weight (Lb.)
 Dry - 2100
 Wet - 2780

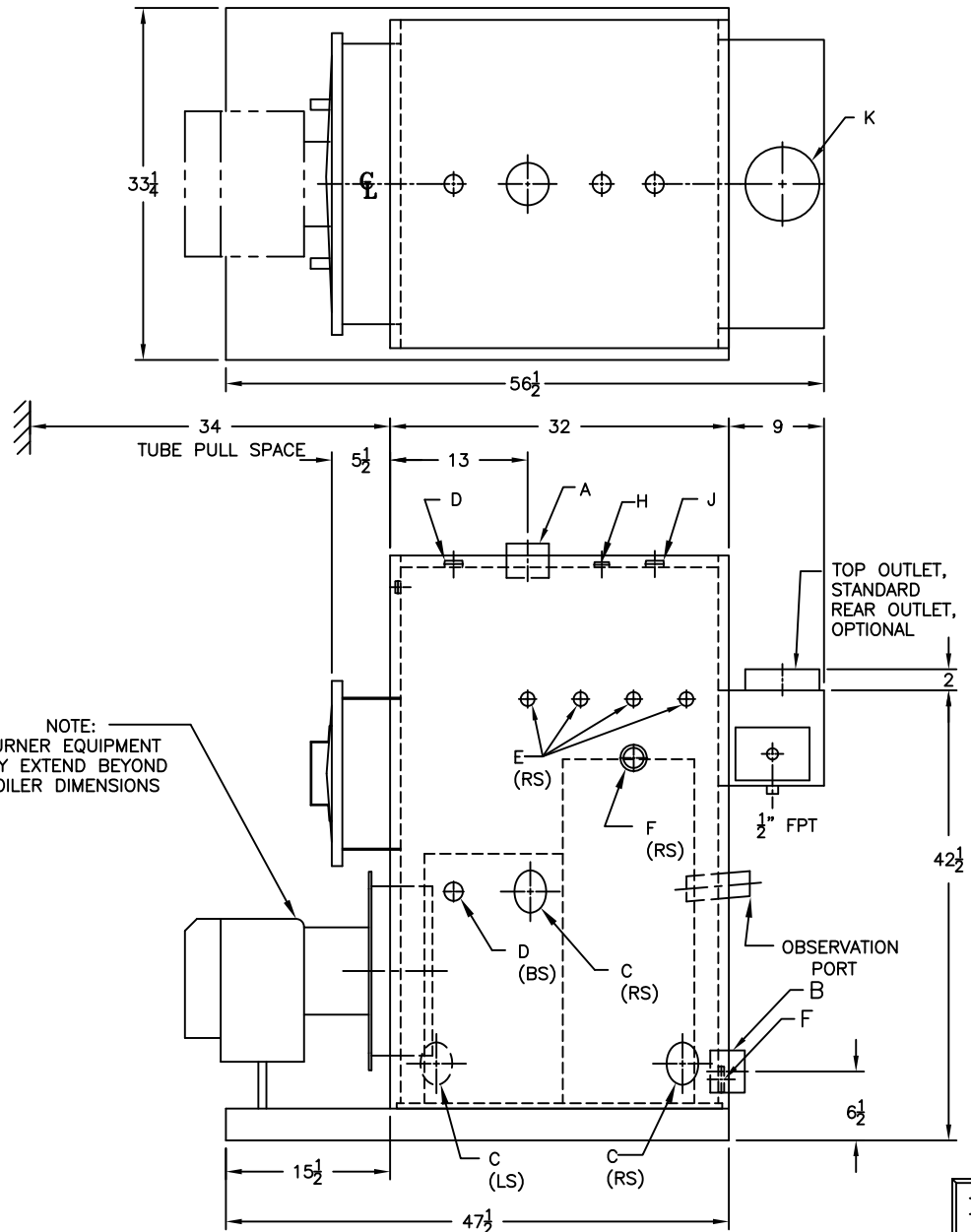
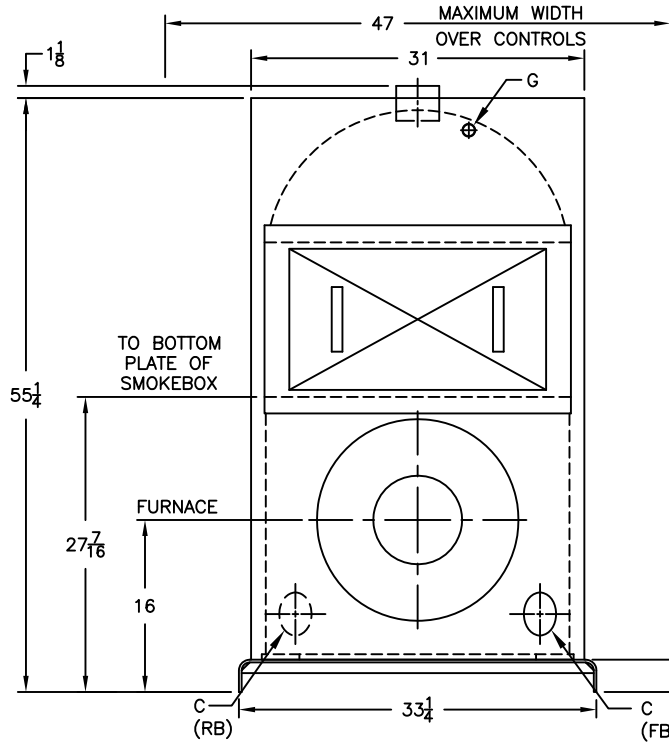

MODEL 4FPW-63
60 PSI WATER

SPECIFICATIONS SUBJECT TO CHANGE WITHOUT NOTICE ALL CONNECTIONS ARE THREADED UNLESS OTHERWISE SPECIFIED
 THIS DOCUMENT CONTAINS CONFIDENTIAL INFORMATION WHICH IS THE PROPERTY OF BURNHAM COMMERCIAL. THIS DOCUMENT MAY NOT BE REPRODUCED, TRANSFERRED OR USED, OR ITS CONTENTS DISCLOSED, WITHOUT THE WRITTEN PERMISSION OF THE OWNER.