

BURNHAM®

Commercial Boilers

LEGEND CONNECTIONS

- A = 4" FLANGED SUPPLY
- B = 4" RETURN
- C = 3" x 4" HANDHOLE
- D = 1" WATER COLUMN
- E = 3/4" AQUASTAT
- F = 1-1/2" DRAIN/WASHOUT
- G = 1/2" TEMPERATURE GAUGE
- H = 1" SAFETY/RELIEF VALVE
- J = 1" AUXILIARY CONNECTION
- K = 10" NOMINAL FLUE DIAMETER

RATINGS AND DATA

Shell Diameter : 32 $\frac{3}{8}$ "

Heating Surface - Sq. Ft.
 Fireside - 194
 Waterside - 209

Firetubes
 Number - 61
 Diameter - 2" O.D.

Furnace
 Volume (Cubic Feet) - 30.2

Water Content
 Water - 248 Gal. (U.S.)

Approximate Weight (Lb.)
 Dry - 4600
 Wet - 6670

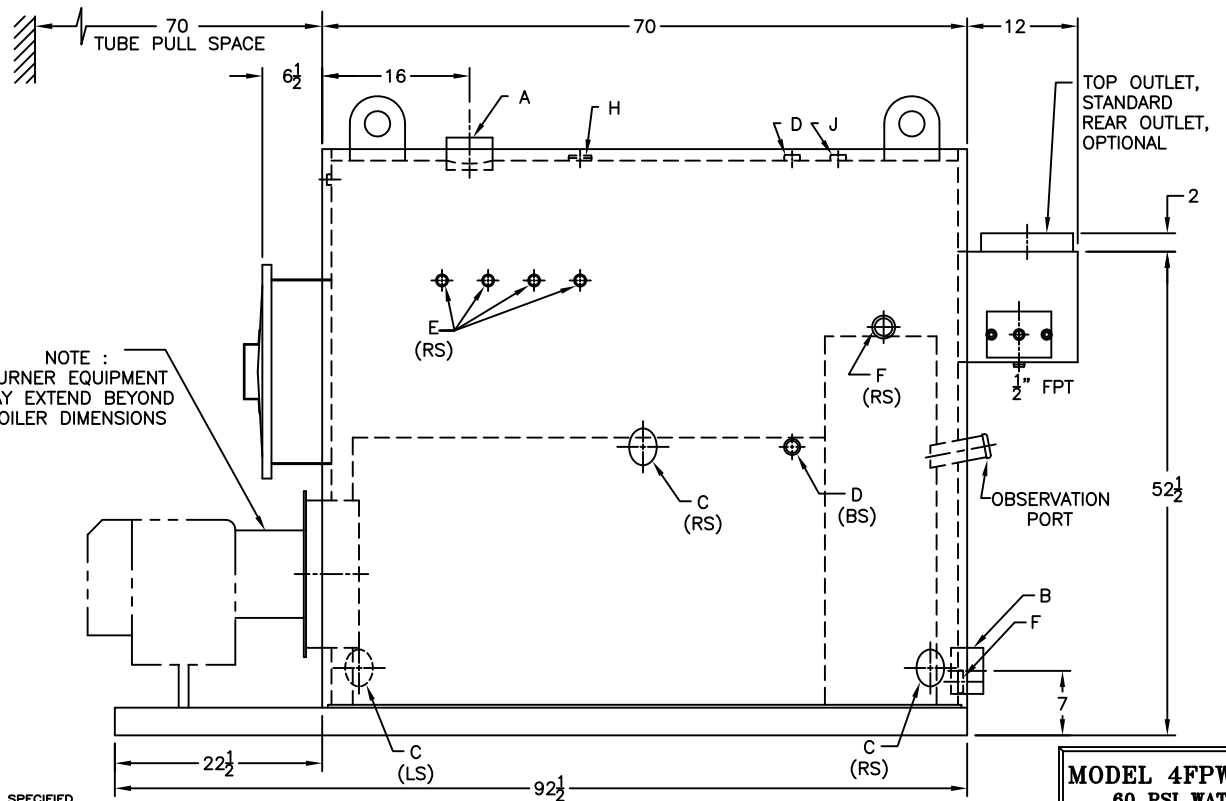
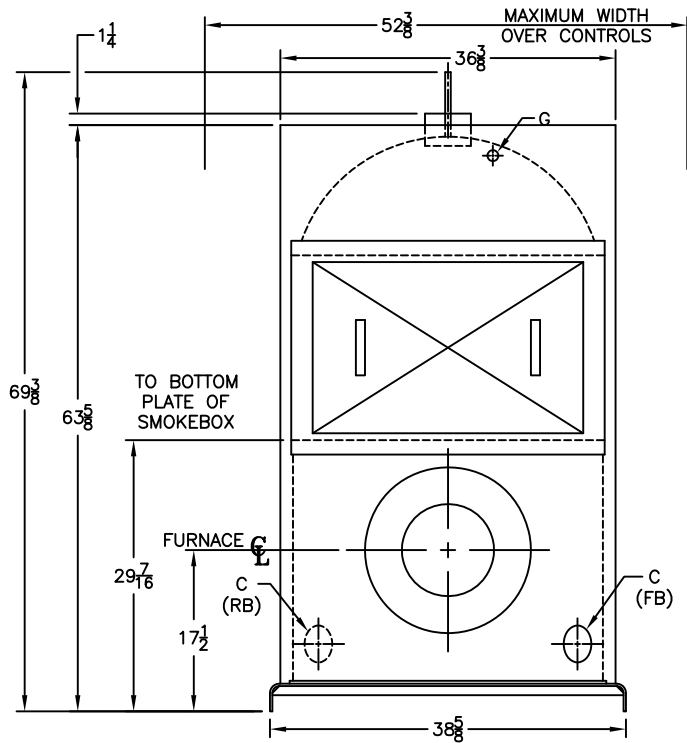
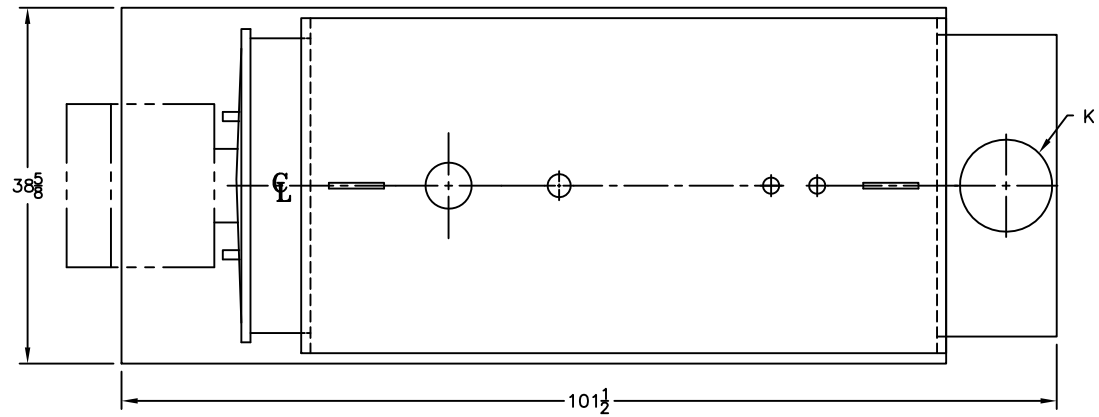

NOTE :
 BURNER EQUIPMENT
 MAY EXTEND BEYOND
 BOILER DIMENSIONS

MODEL 4FPW-209
60 PSI WATER

SPECIFICATIONS SUBJECT TO CHANGE WITHOUT NOTICE ALL CONNECTIONS ARE THREADED UNLESS OTHERWISE SPECIFIED
 THIS DOCUMENT CONTAINS CONFIDENTIAL INFORMATION WHICH IS THE PROPERTY OF BURNHAM COMMERCIAL. THIS DOCUMENT MAY NOT BE REPRODUCED, TRANSFERRED OR USED, OR ITS CONTENTS DISCLOSED, WITHOUT THE WRITTEN PERMISSION OF THE OWNER.