

BURNHAM®

Commercial Boilers

RATINGS AND DATA

Shell Diameter : 41 $\frac{3}{8}$ "
 Heating Surface - Sq. Ft.
 Fireside - 257
 Waterside - 277
 Firetubes
 Number - 90
 Diameter - 2" O.D.

Furnace
 Volume (Cubic Feet) - 41.1

Water Content
 Water - 306 Gal. (U.S.)

Approximate Weight (Lb.)
 Dry - 5500
 Wet - 8050

LEGEND CONNECTIONS

- A = 4" SUPPLY
- B = 4" RETURN
- C = 3" x 4" HANDHOLE
- D = 1" WATER COLUMN
- E = 3/4" AQUASTAT
- F = 1-1/2" DRAIN/WASHOUT
- G = 1/2" TEMPERATURE GAUGE
- H = 1-1/4" SAFETY/RELIEF VALVE
- J = 1" AUXILIARY CONNECTION
- K = 12" NOMINAL FLUE DIAMETER

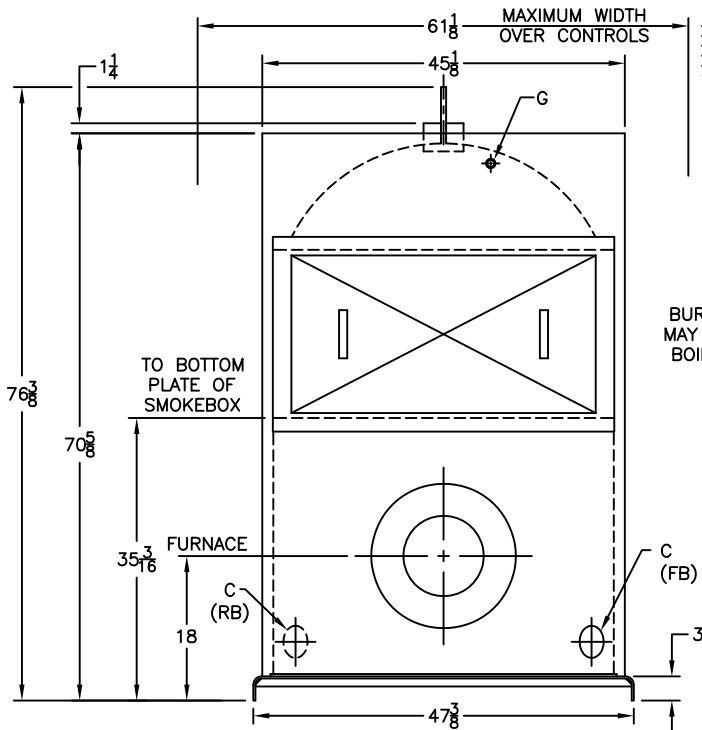
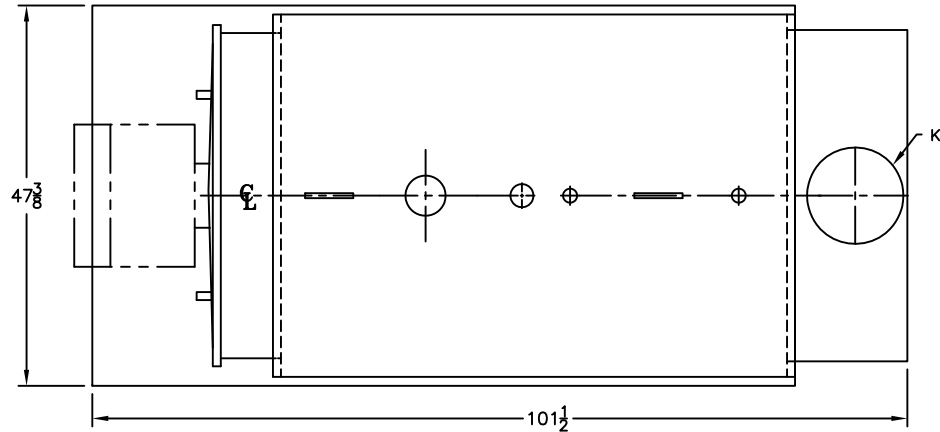

NOTE :
 BURNER EQUIPMENT
 MAY EXTEND BEYOND
 BOILER DIMENSIONS

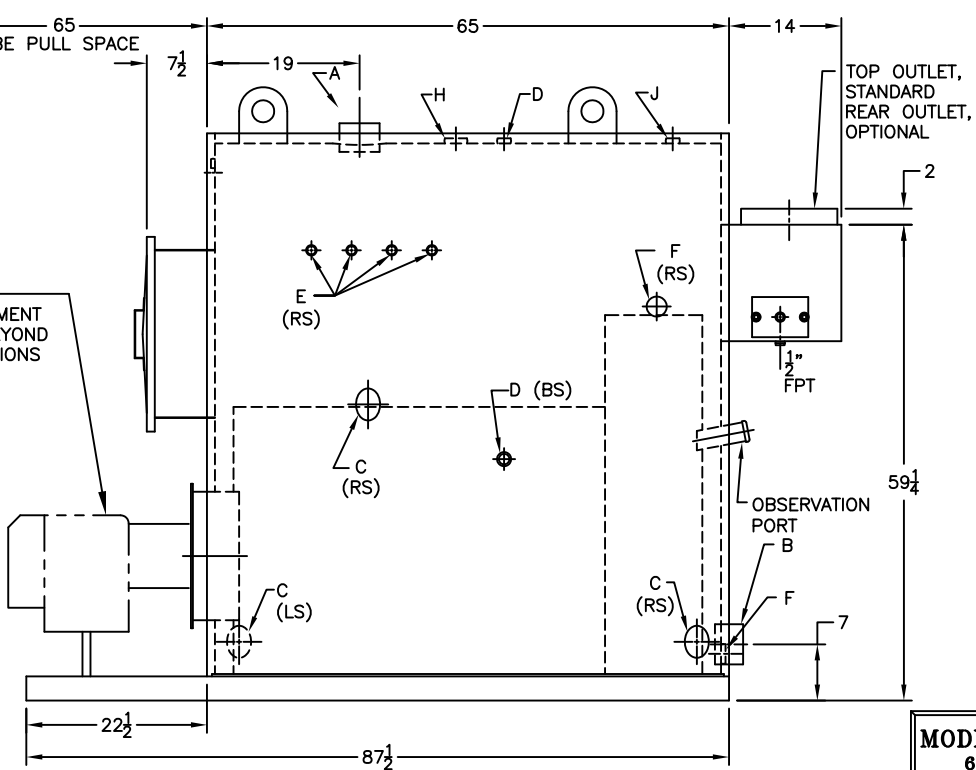

MODEL 4FPW-277
60 PSI WATER

SPECIFICATIONS SUBJECT TO CHANGE WITHOUT NOTICE ALL CONNECTIONS ARE THREADED UNLESS OTHERWISE SPECIFIED
 THIS DOCUMENT CONTAINS CONFIDENTIAL INFORMATION WHICH IS THE PROPERTY OF BURNHAM COMMERCIAL. THIS DOCUMENT MAY NOT BE REPRODUCED, TRANSFERRED OR USED, OR ITS CONTENTS DISCLOSED, WITHOUT THE WRITTEN PERMISSION OF THE OWNER.