

BURNHAM®

Commercial Boilers

LEGEND CONNECTIONS

- A = 8" FLANGED SUPPLY (150#)
- B = 4" RETURN (STEAM)
- 6" FLANGED RETURN(WATER-150#)
- C = 3" x 4" HANDHOLE
- D = 1" WATER COLUMN
- E = 3/4" AQUASTAT
- F = 2" WASHOUT
- G = 1-1/2" SURFACE BLOWOFF
- H = 2" SAFETY/RELIEF VALVE
- 2-1/2" SAFETY/RELIEF VALVE (2)
- J = 12" X 16" MANHOLE
- K = 22" NOMINAL FLUE DIAMETER

RATINGS AND DATA

Shell Diameter : 66"

Heating Surface - Sq. Ft.
 Fireside - 1157
 Waterside - 1250

Firetubes
 Number - 158
 Diameter - 3" O.D.

Furnace
 Volume (Cubic Feet) - 160.7

Water Content
 Steam - 1050 Gal. (U.S.)
 Water - 1330 Gal. (U.S.)

Approximate Weight (Lb.)
 Dry - 17600
 Wet (Steam) - 26360
 Wet (Water) - 28695

LEGEND

- BS = BOTH SIDES
- RS = RIGHT SIDE
- LS = LEFT SIDE
- FB = FRONT OF BOILER
- RB = REAR OF BOILER

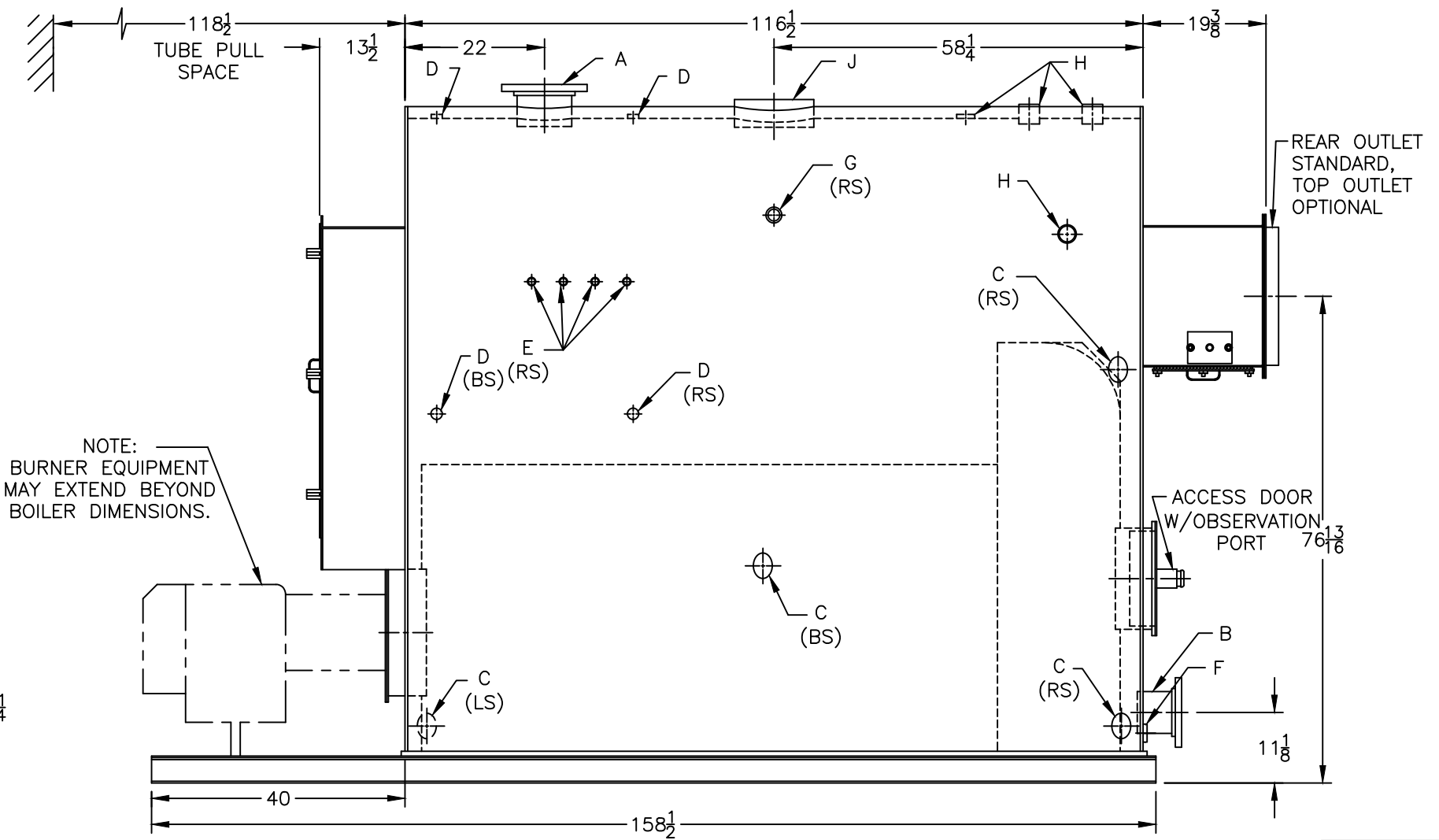
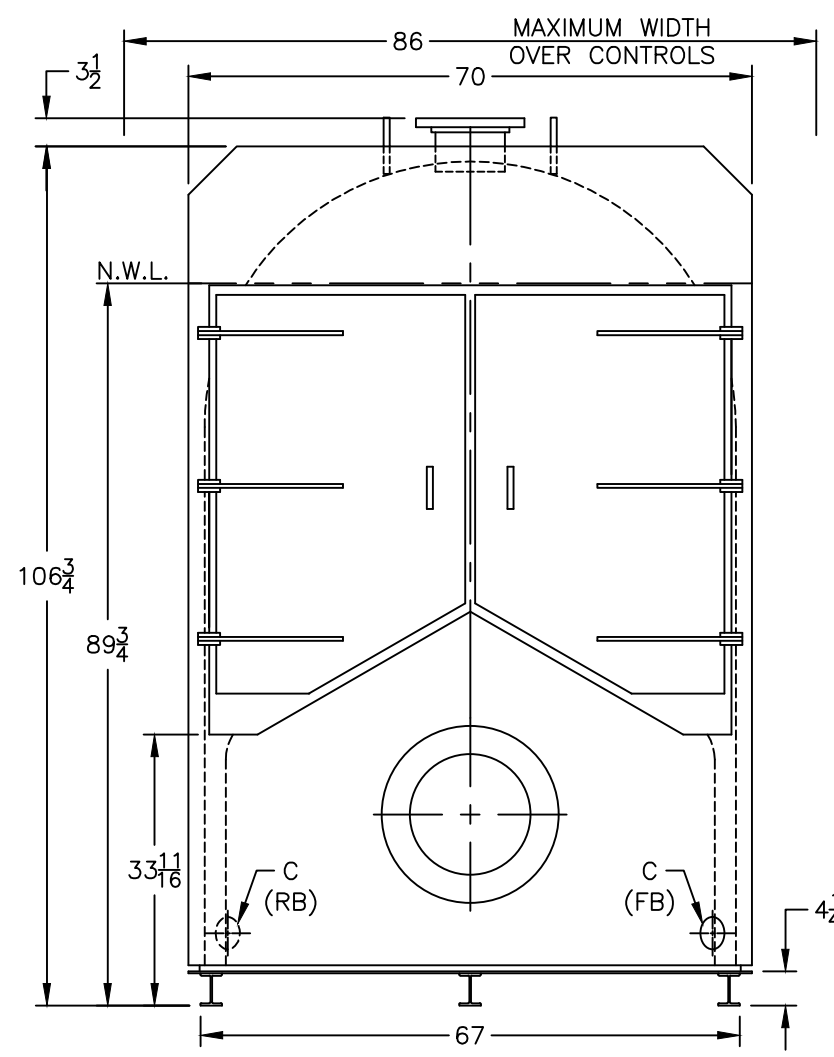
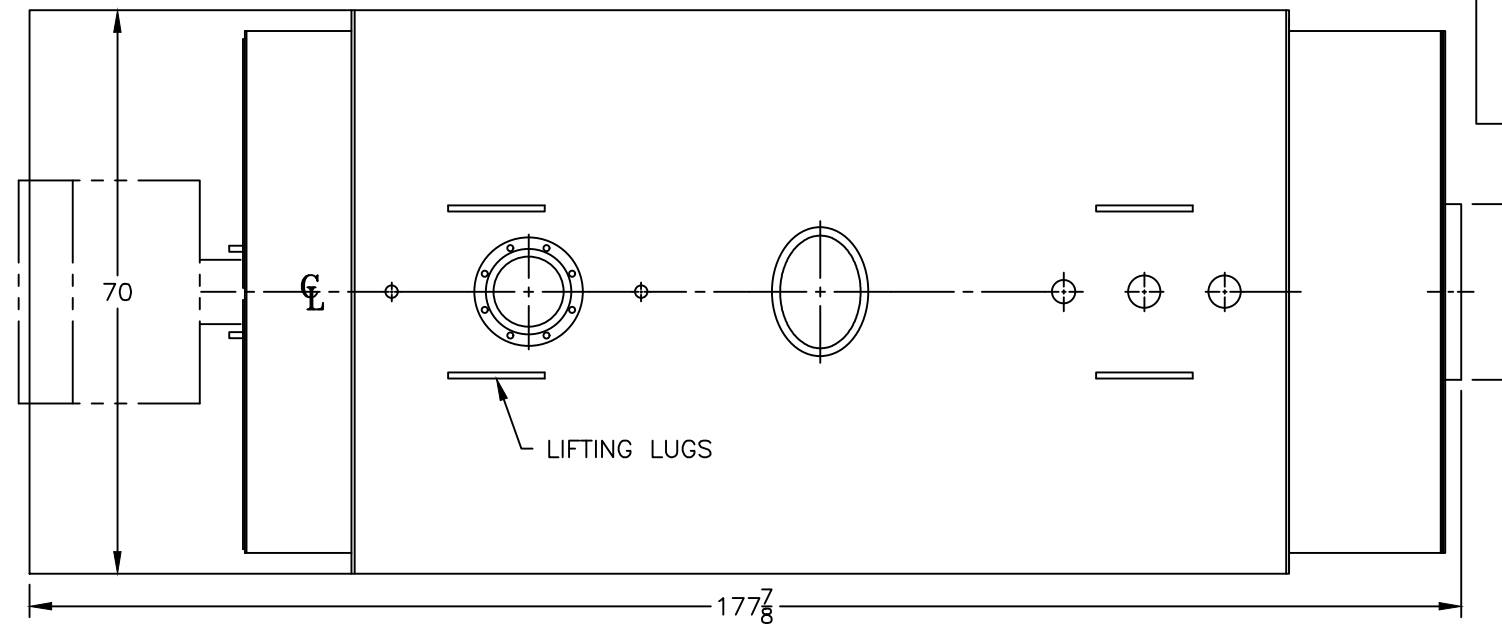

SPECIFICATIONS SUBJECT TO CHANGE WITHOUT NOTICE ALL CONNECTIONS ARE THREADED UNLESS OTHERWISE SPECIFIED
 THIS DOCUMENT CONTAINS CONFIDENTIAL INFORMATION WHICH IS THE PROPERTY OF BURNHAM COMMERCIAL. THIS DOCUMENT MAY NOT BE REPRODUCED, TRANSFERRED OR USED, OR ITS CONTENTS DISCLOSED, WITHOUT THE WRITTEN PERMISSION OF THE OWNER.

MODEL 4FH-1157