

BURNHAM®

Commercial Boilers

RATINGS AND DATA

Shell Diameter : 62"
 Gross Output - BHP : 131.7
 Gross Output - MBH : 4409
 Gross Output - Lbs/Hr : 4544
 Net Rating - MBH : 3423
 Net Rating - Sq. Ft. : 14263
 Safety Valve - Lbs/Hr. : 5000

Heating Surface - Sq. Ft.
 Fireside - 625
 Firetubes
 Number - 86
 Diameter - 2.5" O.D.

Firing Rate
 1000 BTU Gas (MBH) - 5230
 140000 BTU/Gal Oil (GPH) - 36.2
 150000 BTU/Gal Oil (GPH) - 33.8

Water Content
 Pounds - 7761
 Gallons (U.S.) - 930
 Approximate Weight/LBS.
 Dry - 9647
 Wet - 17408

LEGEND CONNECTIONS

- A = 8" FLANGED SUPPLY (150#)
- B = 4" RETURN
- C = 3" x 4" HANDHOLE
- D = 1" WATER COLUMN
- E = 3/4" AQUASTAT
- F = 1-1/2" BOTTOM BLOWDOWN
- G = 1-1/2" SURFACE BLOWOFF
- H = 2" AUXILIARY CONNECTION
- J = 3" SAFETY VALVE
- K = 12" X 16" MANHOLE
- L = 12" NOMINAL FLUE DIAMETER

LEGEND

BS = BOTH SIDES
 RS = RIGHT SIDE

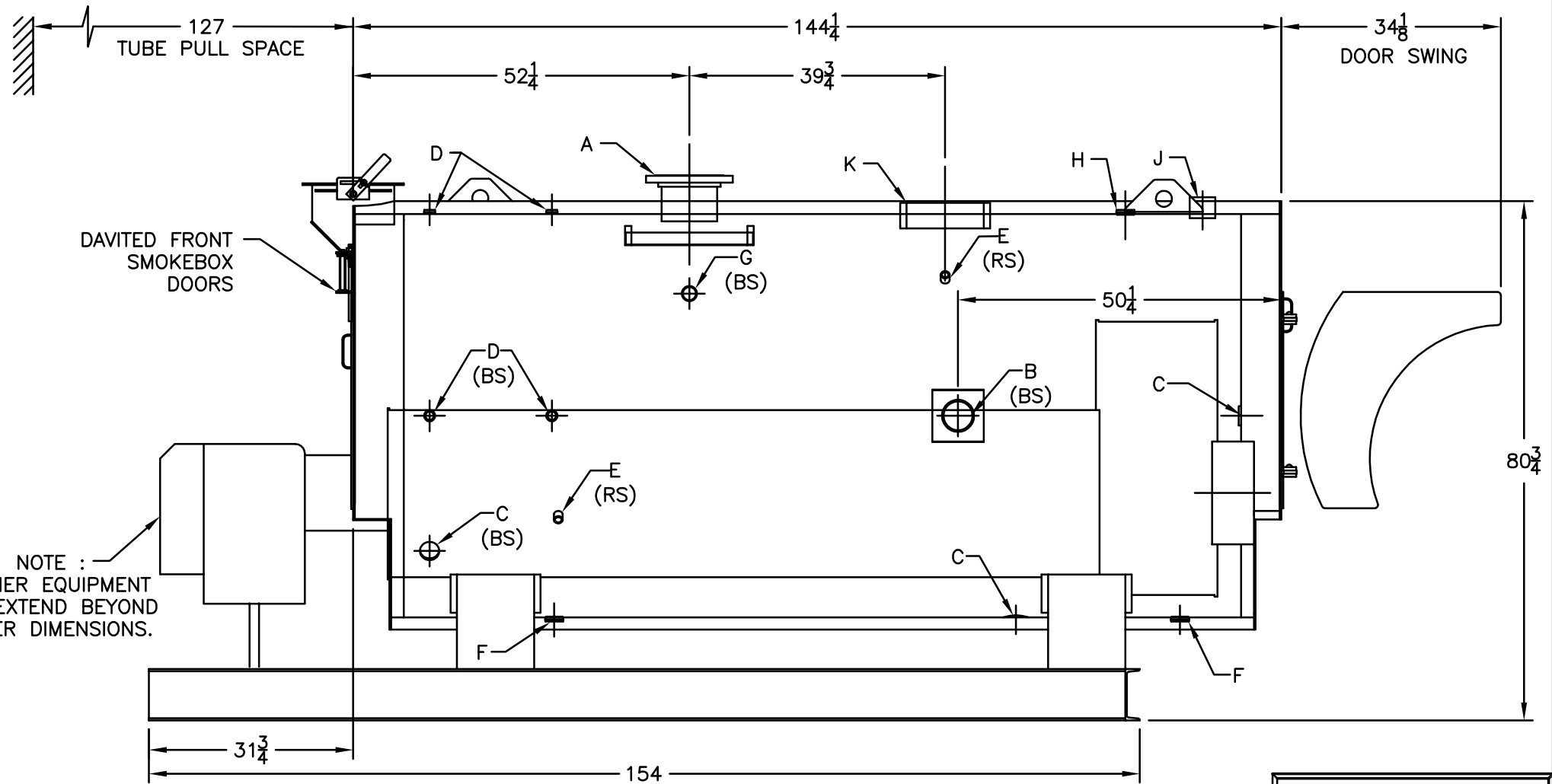
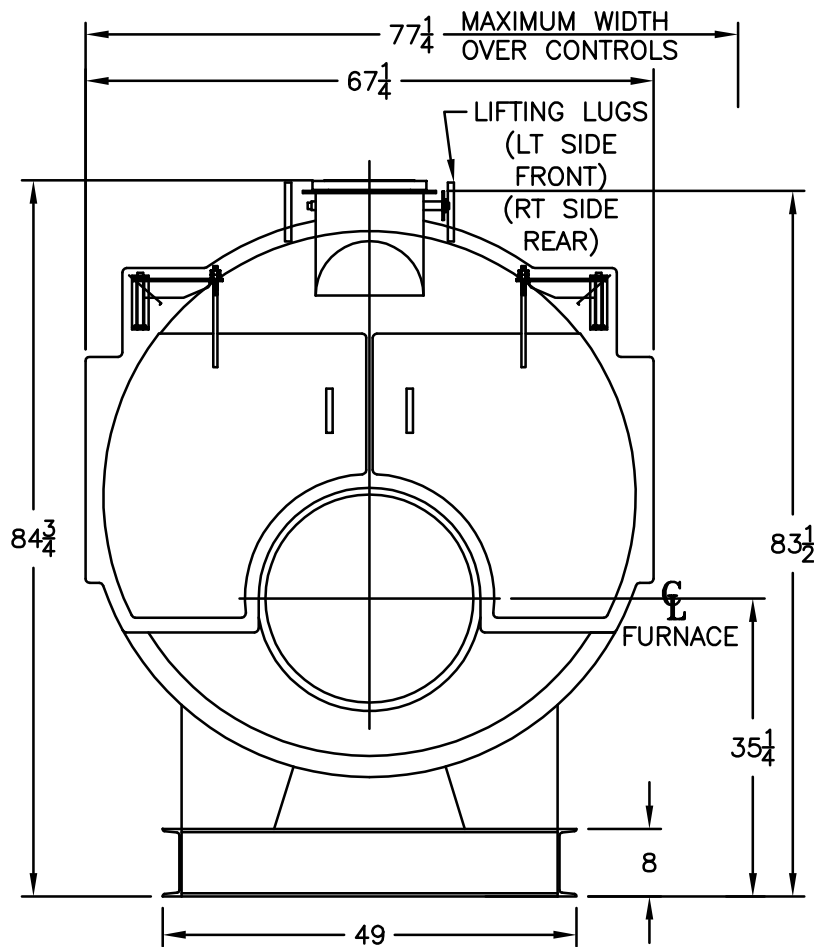
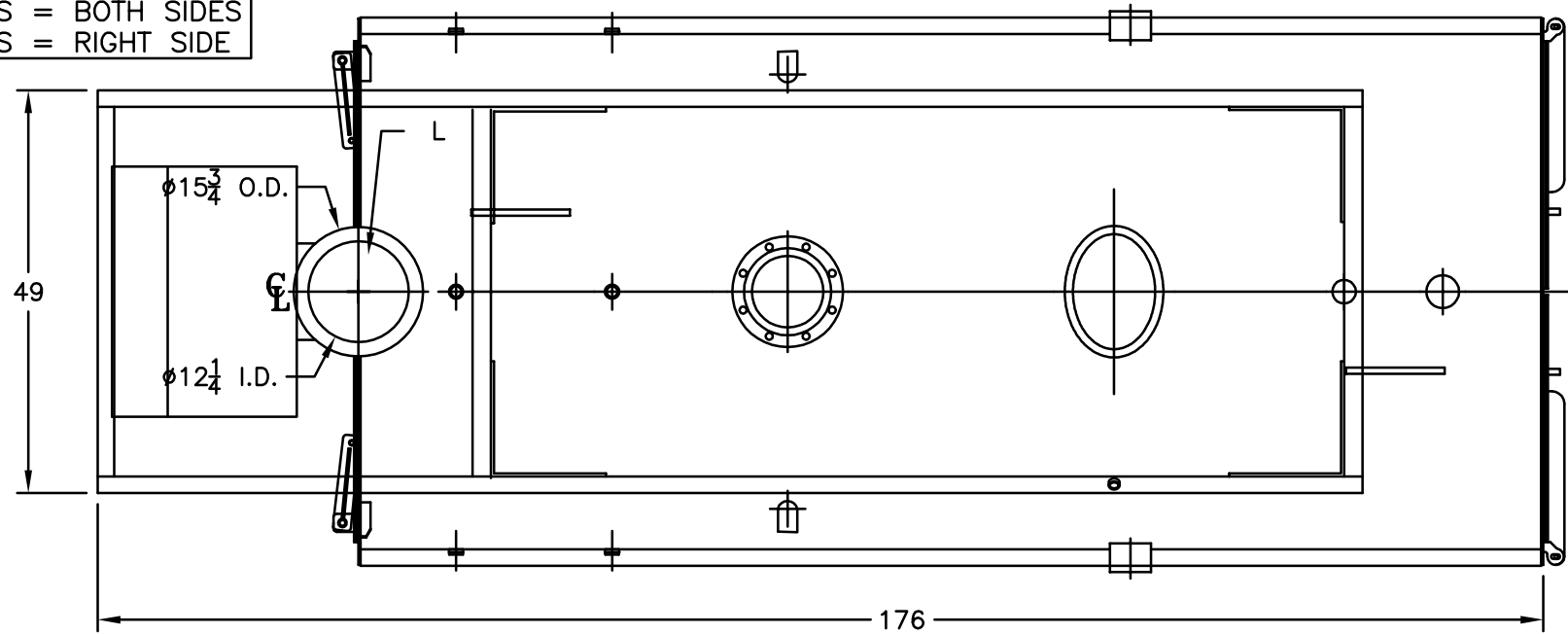

NOTE :
 BURNER EQUIPMENT
 MAY EXTEND BEYOND
 BOILER DIMENSIONS.

MODEL 4SL-125
131.7 BHP
15 PSI STEAM