

# BURNHAM®

## Commercial Boilers

### LEGEND CONNECTIONS

- A = 8" FLANGED SUPPLY (150#)
- B = 4" RETURN
- C = 3" x 4" HANDHOLE
- D = 1" WATER COLUMN
- E = 3/4" AQUASTAT
- F = 2" BOTTOM BLOWDOWN
- G = 2" SURFACE BLOWOFF
- H = 2" AUXILIARY CONNECTION
- J = 2-1/2" SAFETY VALVE  
3" SAFETY VALVE
- K = 12" X 16" MANHOLE
- L = 16" NOMINAL FLUE DIAMETER

### RATINGS AND DATA

Shell Diameter : 70"  
 Gross Output - BHP : 156.8  
 Gross Output - MBH : 5248  
 Gross Output - Lbs/Hr : 5409  
 Net Rating - MBH : 4074  
 Net Rating - Sq. Ft. : 16976  
 Safety Valve - Lbs/Hr. : 6000

Heating Surface - Sq. Ft.  
 Fireside - 750  
 Firetubes  
 Number - 120  
 Diameter - 2.5" O.D.

Firing Rate  
 1000 BTU Gas (MBH) - 6277  
 140000 BTU/Gal Oil (GPH) - 43.3  
 150000 BTU/Gal Oil (GPH) - 40.4

Water Content  
 Pounds - 8108  
 Gallons (U.S.) - 972  
 Approximate Weight/LBS.  
 Dry - 10895  
 Wet - 19003

### LEGEND

BS = BOTH SIDES  
 RS = RIGHT SIDE

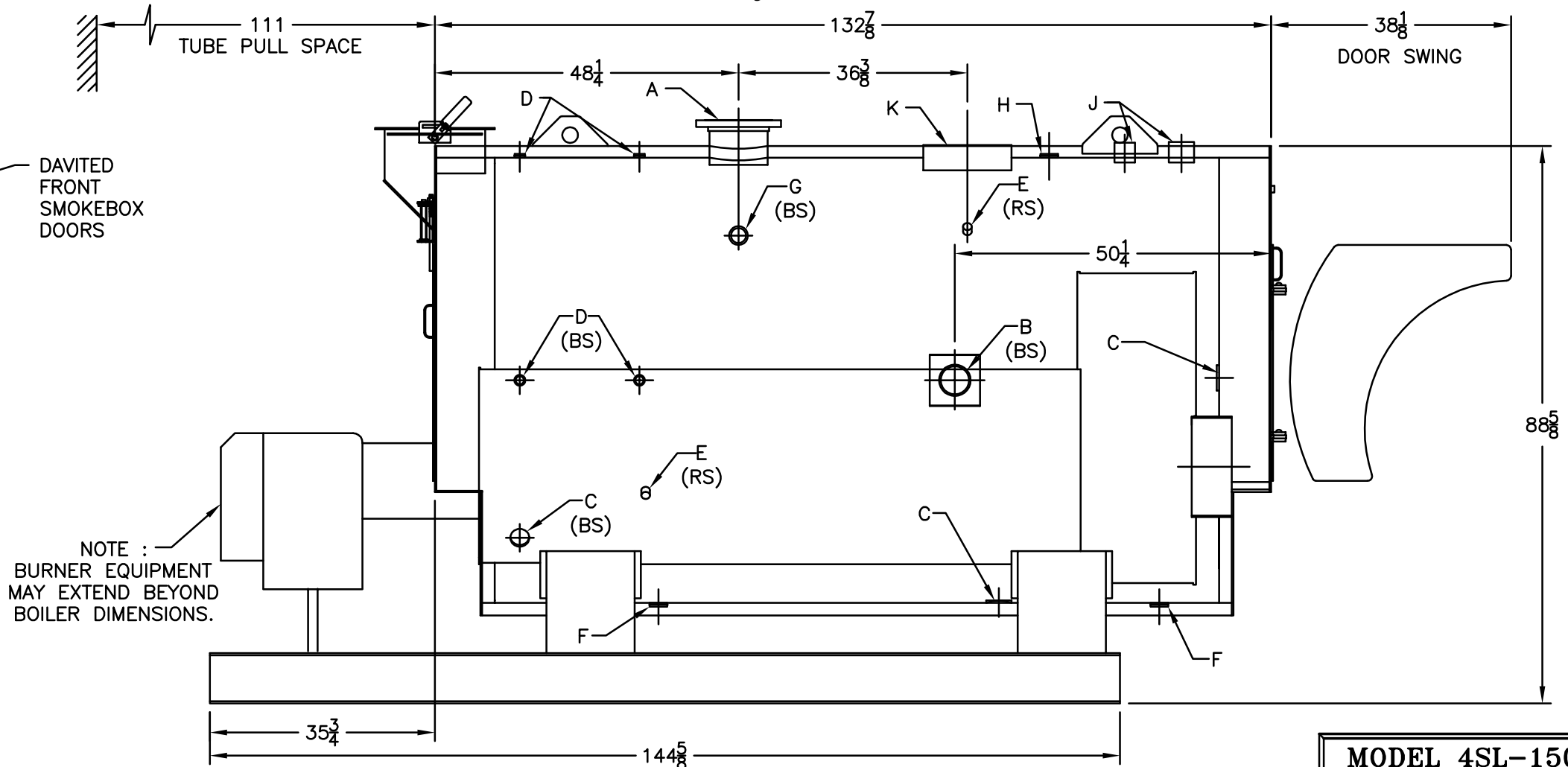
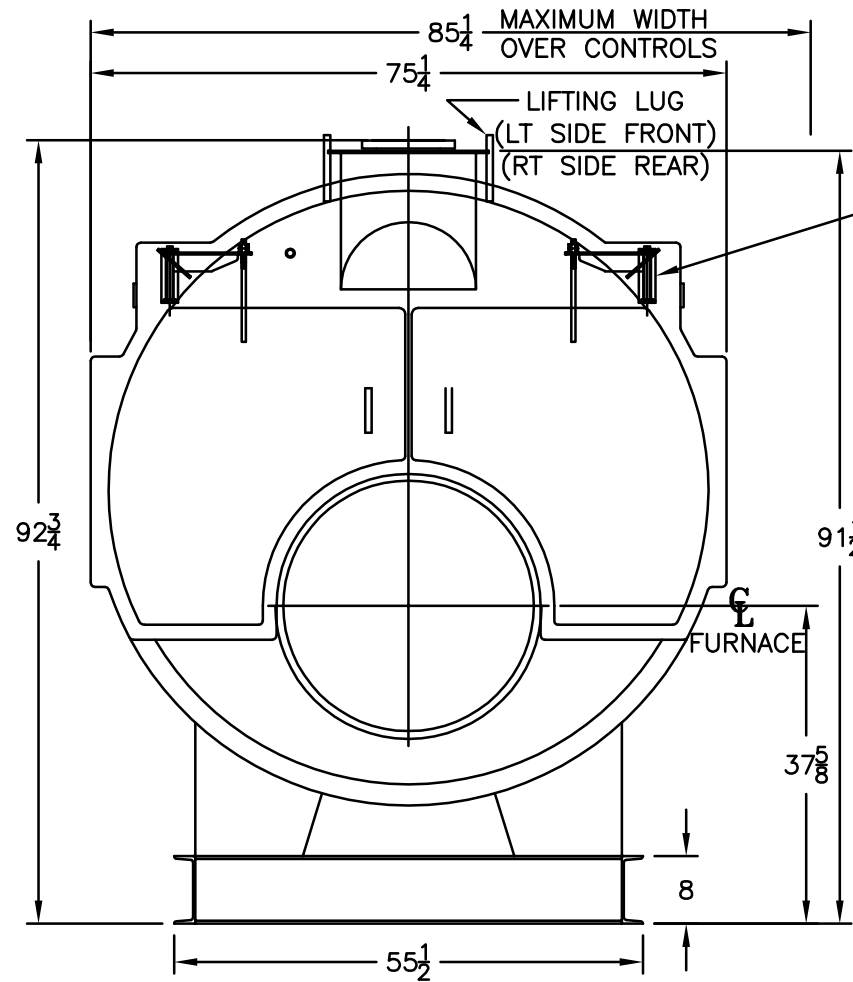
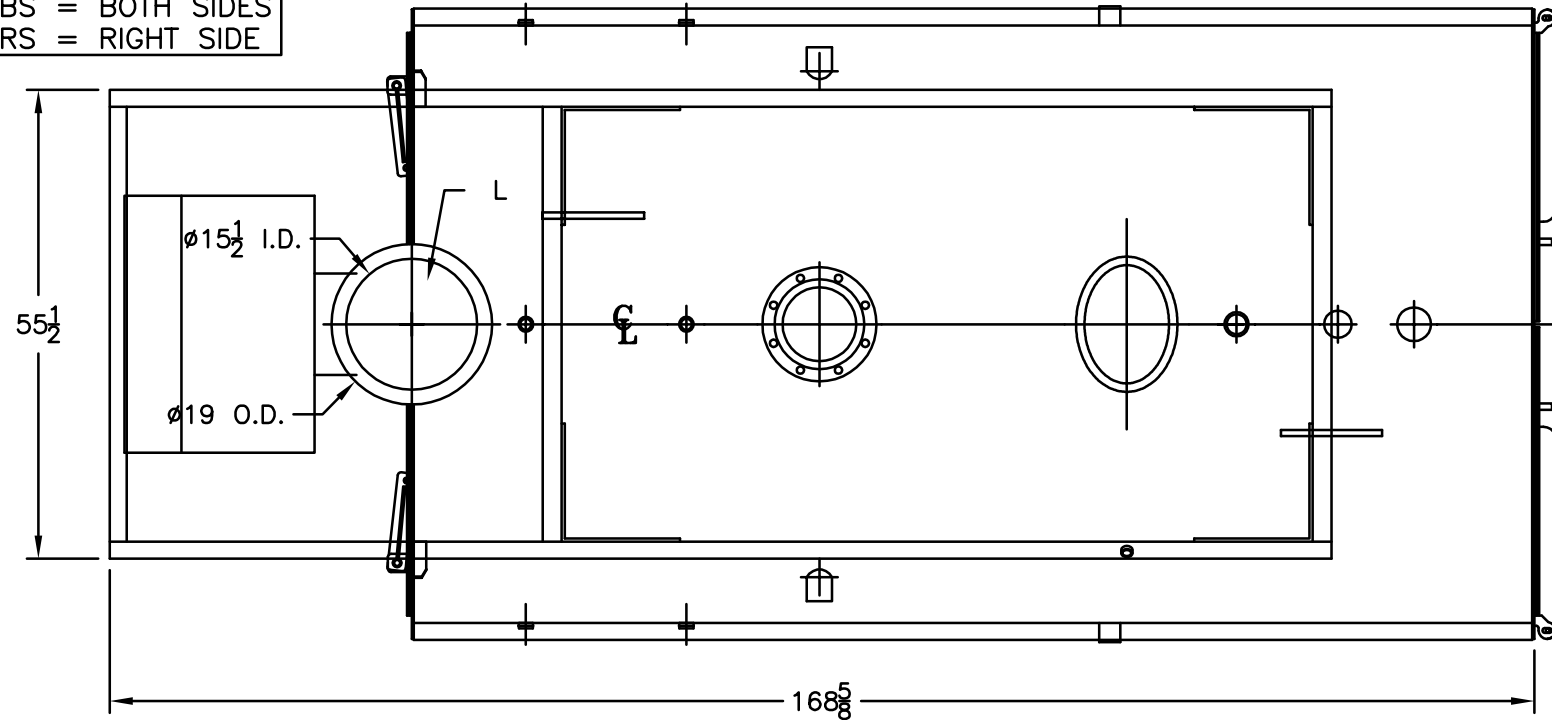

NOTE :  
 BURNER EQUIPMENT  
 MAY EXTEND BEYOND  
 BOILER DIMENSIONS.

**MODEL 4SL-150**  
**156.8 BHP**  
**15 PSI STEAM**