

BURNHAM®

Commercial Boilers

RATINGS AND DATA

Shell Diameter : 70"
 Gross Output - BHP : 184.6
 Gross Output - MBH : 6181
 Gross Output - Lbs/Hr. : 6370
 Net Rating - MBH : 4799
 Net Rating - Sq. Ft. : 19994
 Safety Valve - Lbs/Hr. : 7000

Heating Surface - Sq. Ft.
 Fireside - 875
 Firetubes
 Number - 120
 Diameter - 2.5" O.D.

Firing Rate
 1000 BTU Gas (MBH) - 7323
 140000 BTU/Gal Oil (GPH) - 50.6
 150000 BTU/Gal Oil (GPH) - 47.2

Water Content
 Pounds - 9534
 Gallons (U.S.) - 1143
 Approximate Weight/LBS.
 Dry - 12379
 Wet - 21913

LEGEND

BS = BOTH SIDES
 RS = RIGHT SIDE

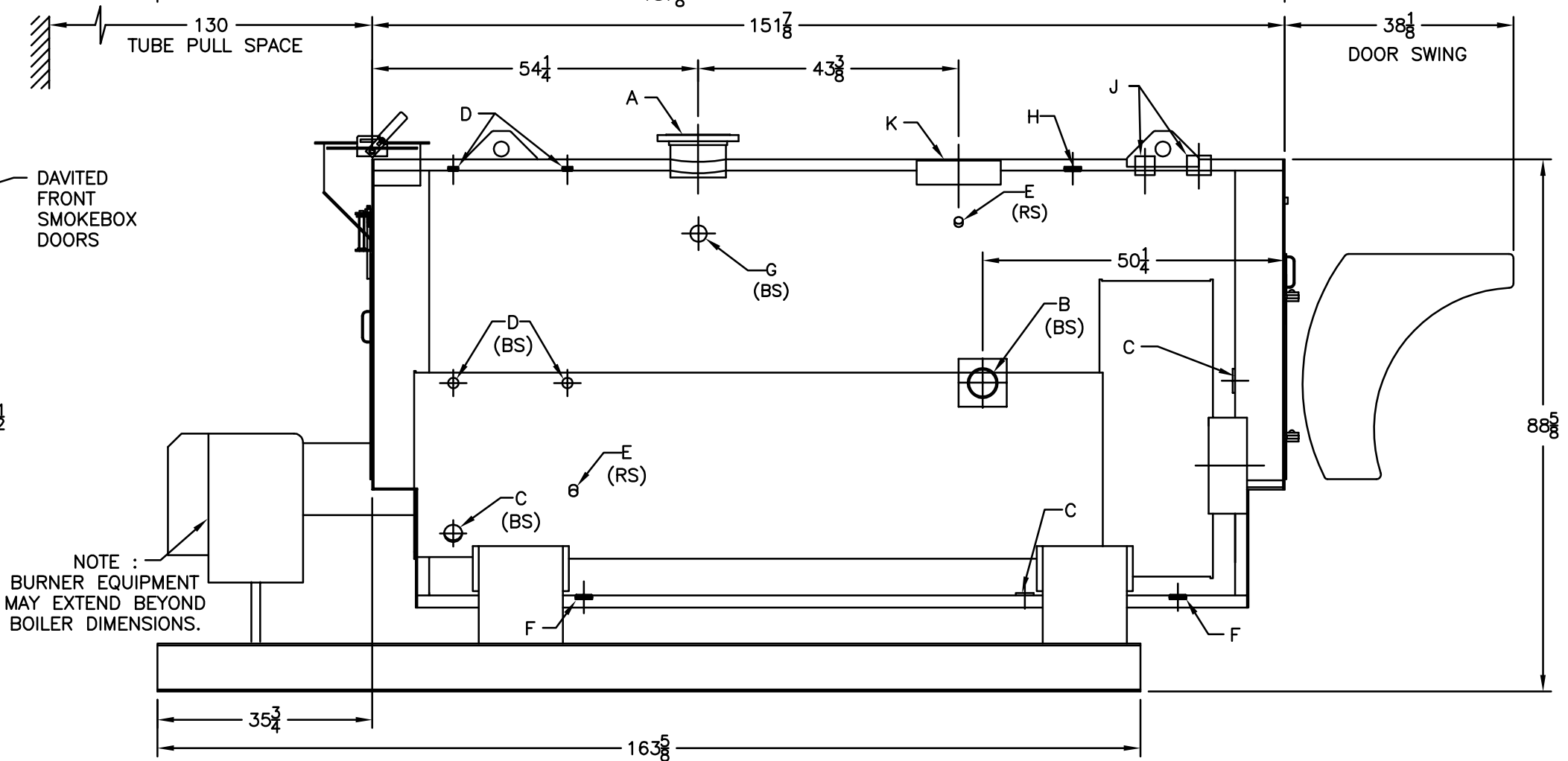
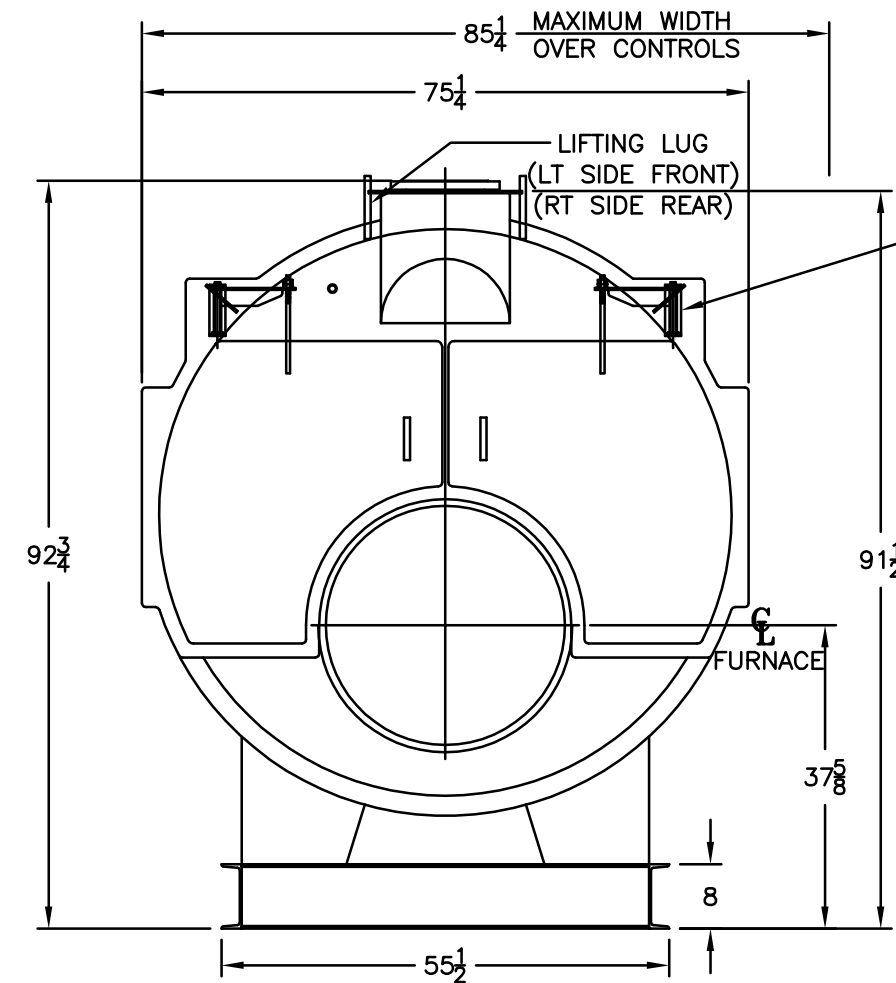
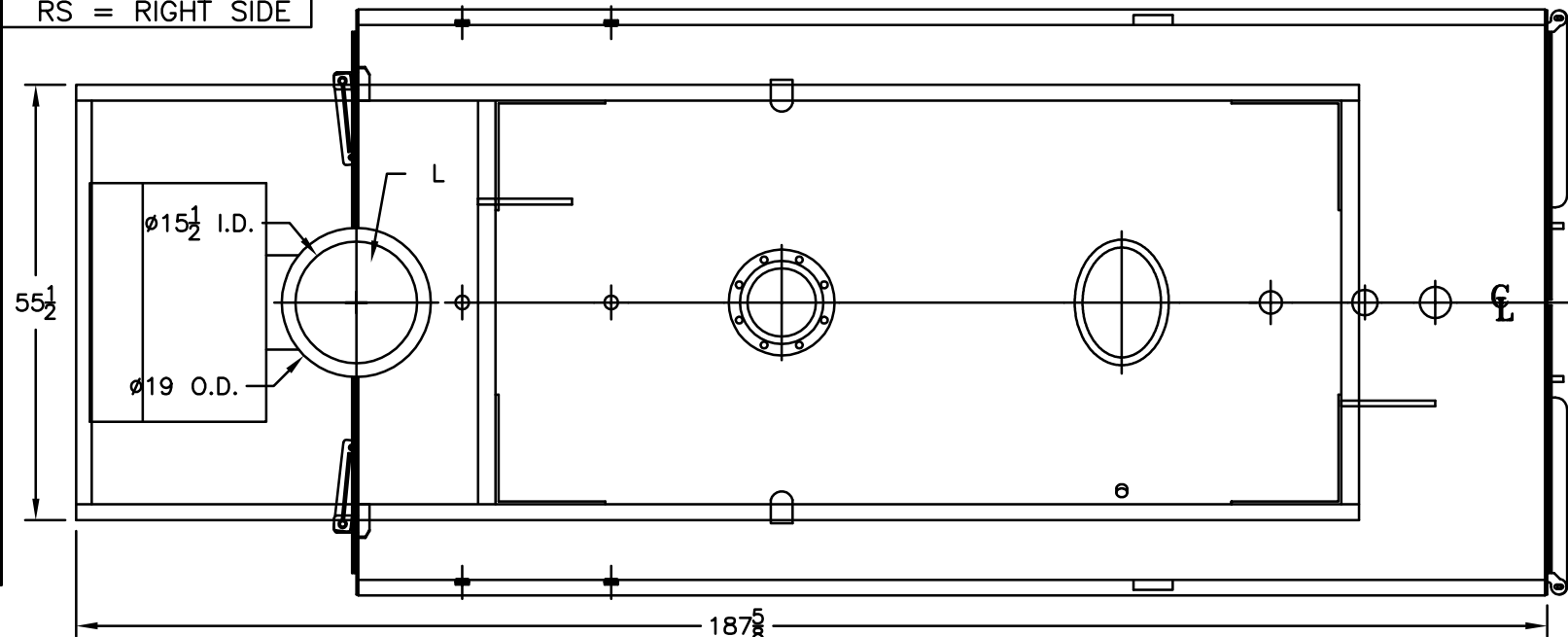

NOTE :
 BURNER EQUIPMENT
 MAY EXTEND BEYOND
 BOILER DIMENSIONS.

MODEL 4SL-175
184.6 BHP
15 PSI STEAM

SPECIFICATIONS SUBJECT TO CHANGE WITHOUT NOTICE ALL CONNECTIONS ARE THREADED UNLESS OTHERWISE SPECIFIED
 THIS DOCUMENT CONTAINS CONFIDENTIAL INFORMATION WHICH IS THE PROPERTY OF BURNHAM COMMERCIAL. THIS DOCUMENT MAY NOT BE REPRODUCED, TRANSFERRED OR USED, OR ITS CONTENTS DISCLOSED, WITHOUT THE WRITTEN PERMISSION OF THE OWNER.