

# BURNHAM®

## Commercial Boilers

### RATINGS AND DATA

Shell Diameter : 70"  
 Gross Output - BHP : 212.3  
 Gross Output - MBH : 7105  
 Gross Output - Lbs/Hr. : 7323  
 Net Rating - MBH : 5517  
 Net Rating - Sq. Ft. : 22986  
 Safety Valve - Lbs/Hr. : 8000

Heating Surface - Sq. Ft.  
 Fireside - 1000  
 Firetubes  
 Number - 120  
 Diameter - 2.5" O.D.

Firing Rate  
 1000 BTU Gas (MBH) - 8369  
 140000 BTU/Gal Oil (GPH) - 58  
 150000 BTU/Gal Oil (GPH) - 54.1

Water Content  
 Pounds - 10960  
 Gallons (U.S.) - 1314  
 Approximate Weight/LBS.  
 Dry - 13574  
 Wet - 24534

### LEGEND

BS = BOTH SIDES  
 RS = RIGHT SIDE

### LEGEND CONNECTIONS

- A = 8" FLANGED SUPPLY (150#)
- B = 4" RETURN
- C = 3" x 4" HANDHOLE
- D = 1" WATER COLUMN
- E = 3/4" AQUASTAT
- F = 2" BOTTOM BLOWDOWN
- G = 2" SURFACE BLOWOFF
- H = 2" AUXILIARY CONNECTION
- J = 2-1/2" SAFETY VALVE
- 3" SAFETY VALVE
- K = 12" X 16" MANHOLE
- L = 16" NOMINAL FLUE DIAMETER

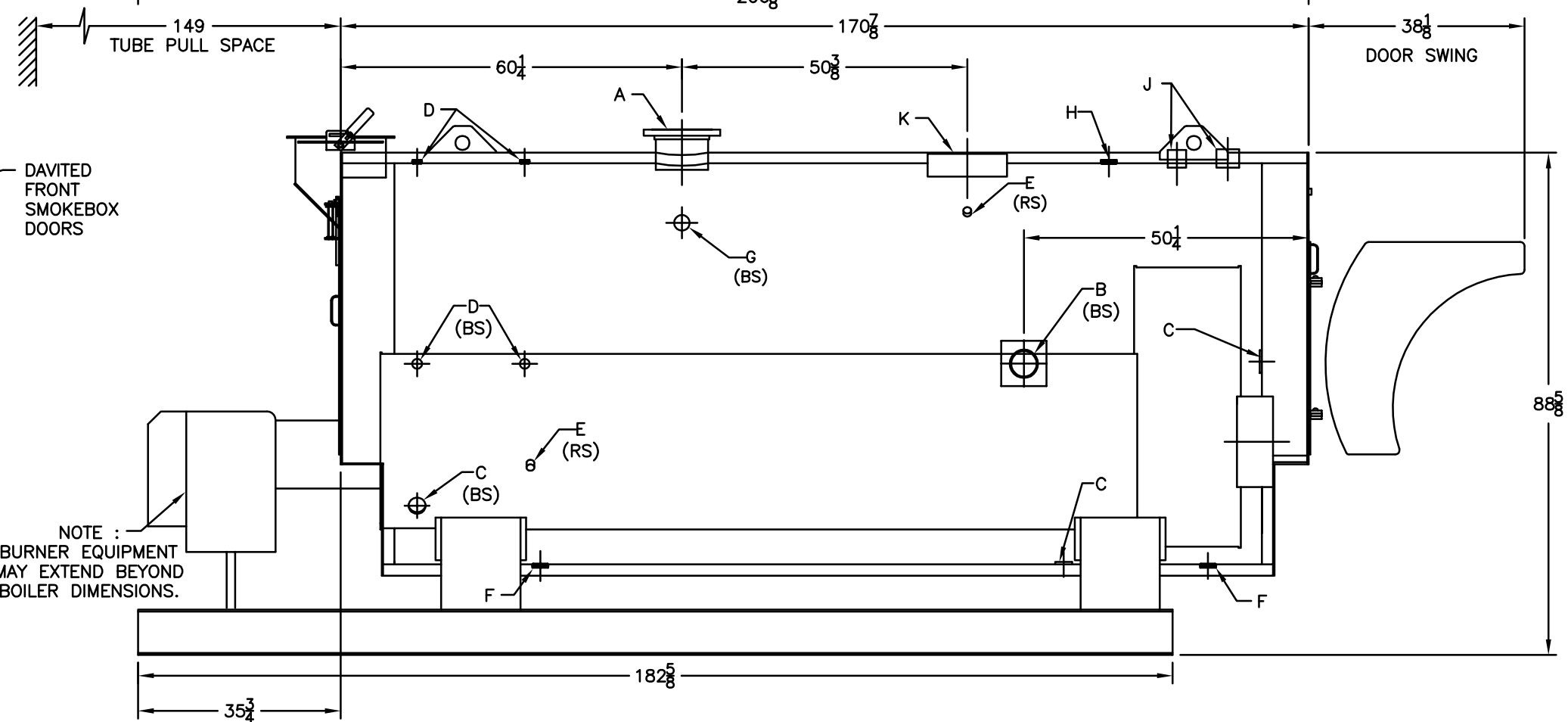
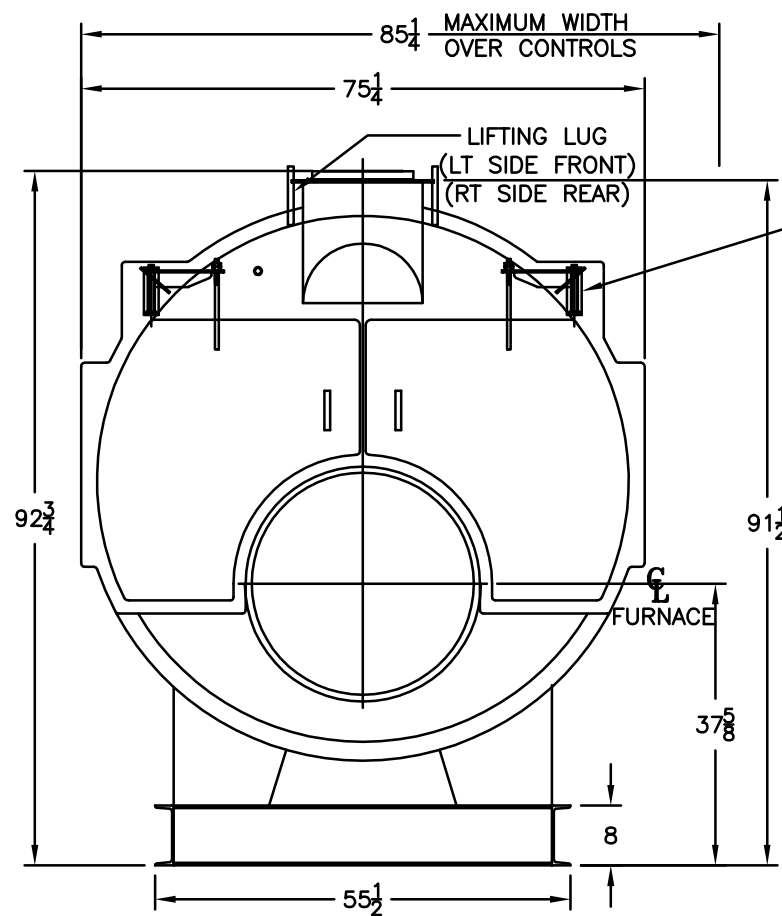
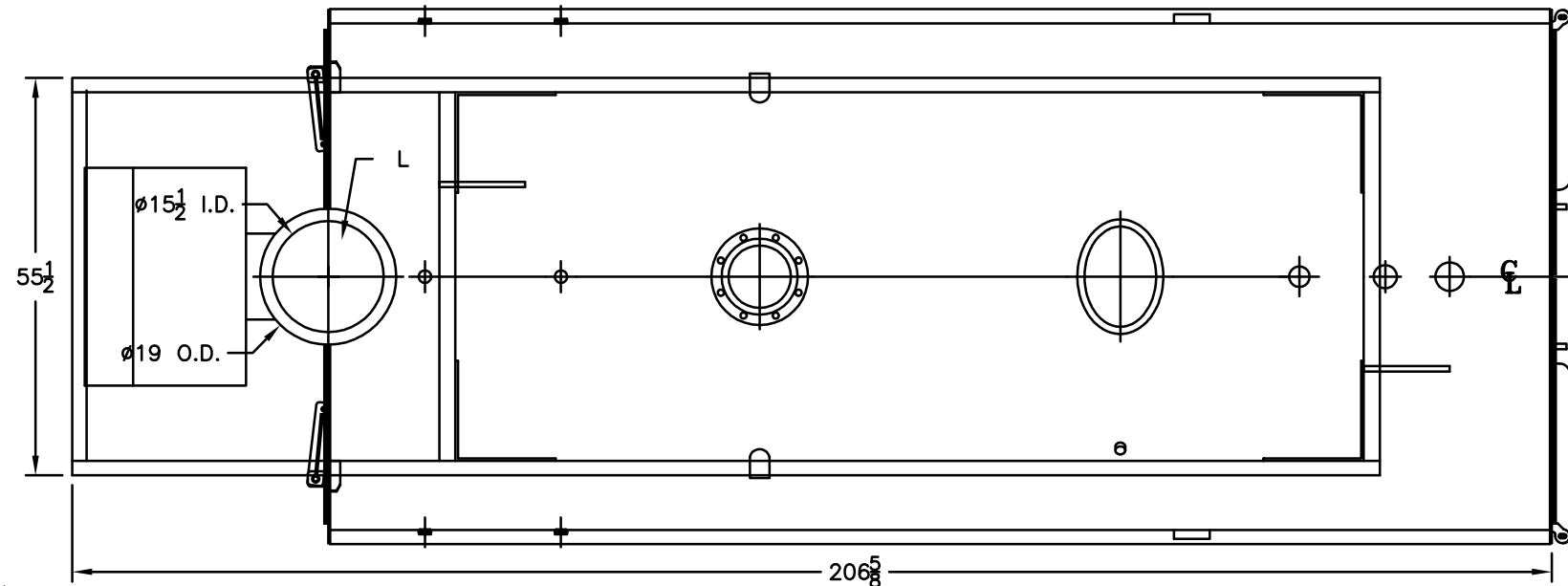

NOTE :  
 BURNER EQUIPMENT  
 MAY EXTEND BEYOND  
 BOILER DIMENSIONS.

**MODEL 4SL-200**  
**212.3 BHP**  
**15 PSI STEAM**