

# BURNHAM®

## Commercial Boilers

### LEGEND CONNECTIONS

- A = 4" FLANGED SUPPLY (300#)
- B = 1-1/4" RETURN
- C = 3" x 4" HANDHOLE
- D = 1" WATER COLUMN
- E = 3/4" AQUASTAT
- F = 1-1/2" BOTTOM BLOWDOWN
- G = 1-1/2" SURFACE BLOWOFF
- H = 2" AUXILIARY CONNECTION
- J = 1" SAFETY VALVE
- 1-1/4" SAFETY VALVE
- K = 12" X 16" MANHOLE
- L = 12" NOMINAL FLUE DIAMETER

### RATINGS AND DATA

Shell Diameter : 62"  
 Gross Output - BHP : 100  
 Gross Output - MBH : 3348  
 Gross Output - Lbs/Hr : 3450  
 Net Rating - MBH : 2679  
 Net Rating - Sq. Ft. : 11163  
 Safety Valve - Lbs/Hr. : 3905

Heating Surface - Sq. Ft.  
 Fireside - 500  
 Firetubes  
 Number - 86  
 Diameter - 2.5" O.D.

Firing Rate  
 1000 BTU Gas (MBH) - 4184  
 140000 BTU/Gal Oil (GPH) - 28.8  
 150000 BTU/Gal Oil (GPH) - 26.9

Water Content  
 Pounds - 6461  
 Gallons (U.S.) - 775  
 Approximate Weight/LBS.  
 Dry - 9103  
 Wet - 15564

### LEGEND

BS = BOTH SIDES  
 RS = RIGHT SIDE

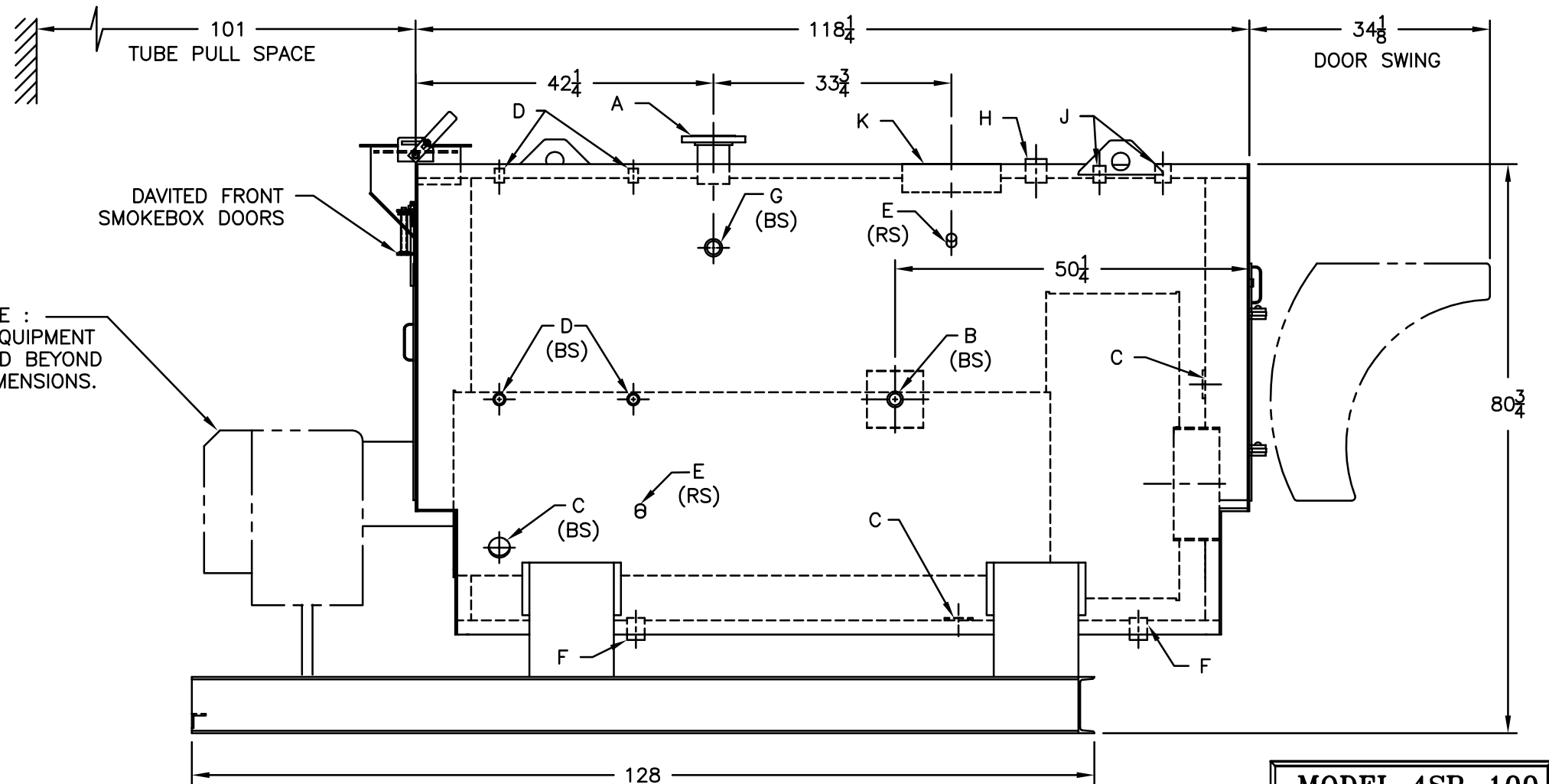
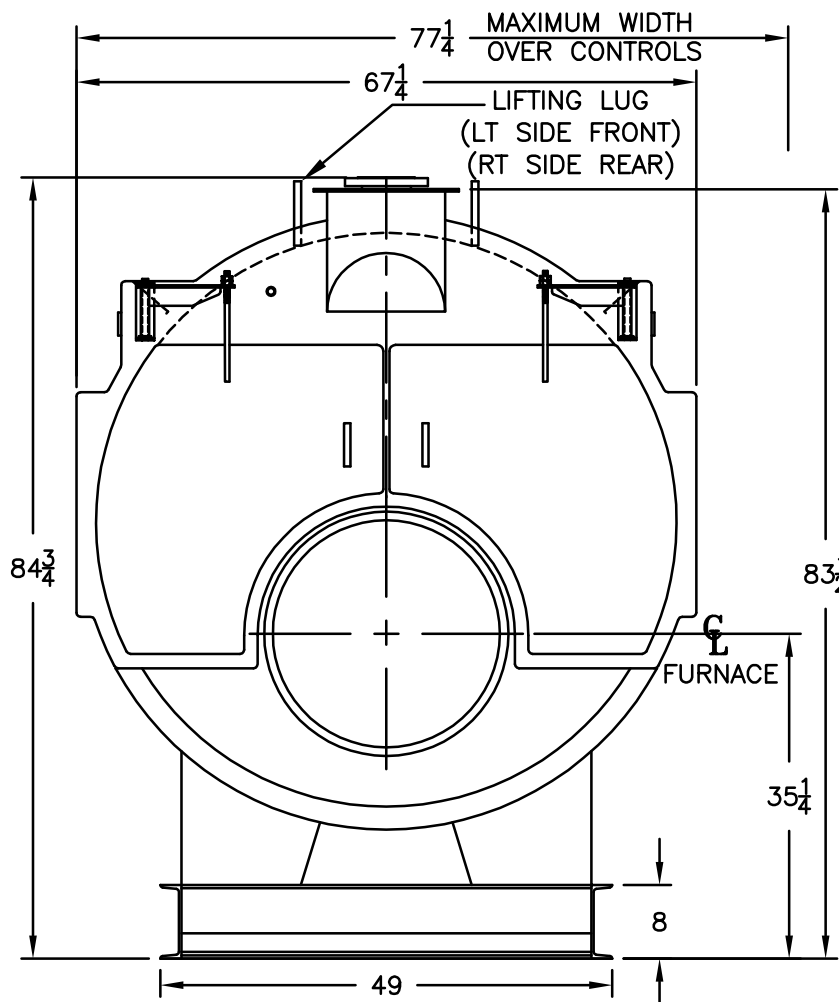
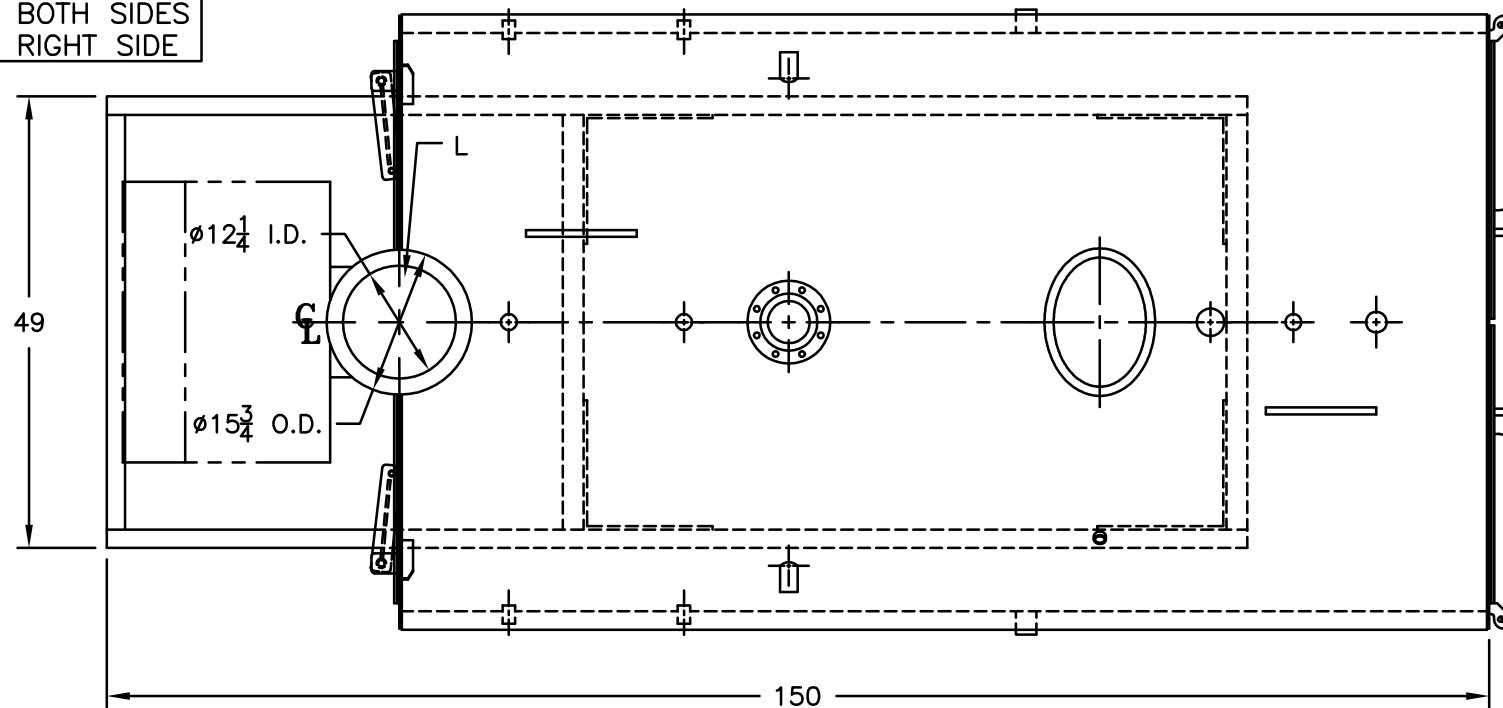

SPECIFICATIONS SUBJECT TO CHANGE WITHOUT NOTICE ALL CONNECTIONS ARE THREADED UNLESS OTHERWISE SPECIFIED  
 THIS DOCUMENT CONTAINS CONFIDENTIAL INFORMATION WHICH IS THE PROPERTY OF BURNHAM COMMERCIAL. THIS DOCUMENT MAY NOT BE REPRODUCED, TRANSFERRED OR USED, OR ITS CONTENTS DISCLOSED, WITHOUT THE WRITTEN PERMISSION OF THE OWNER.

**MODEL 4SP-100**  
**100 BHP**  
**150 PSI STEAM**