

BURNHAM®

Commercial Boilers

RATINGS AND DATA

Shell Diameter : 70"
 Gross Output - BHP : 200
 Gross Output - MBH : 6695
 Gross Output - Lbs/Hr : 6900
 Net Rating - MBH : 5357
 Net Rating - Sq. Ft. : 22321
 Safety Valve - Lbs/Hr. : 7811

Heating Surface - Sq. Ft.
 Fireside - 1000
 Firetubes
 Number - 120
 Diameter - 2.5" O.D.

Firing Rate
 1000 BTU Gas (MBH) - 8369
 140000 BTU/Gal Oil (GPH) - 58
 150000 BTU/Gal Oil (GPH) - 54.1

Water Content
 Pounds - 11384
 Gallons (U.S.) - 1365
 Approximate Weight/LBS.
 Dry - 14908
 Wet - 26292

LEGEND CONNECTIONS

- A = 6" FLANGED SUPPLY (300#)
- B = 1-1/2" RETURN
- C = 3" x 4" HANDHOLE
- D = 1" WATER COLUMN
- E = 3/4" AQUASTAT
- F = 2" BOTTOM BLOWDOWN
- G = 2" SURFACE BLOWOFF
- H = 2" AUXILIARY CONNECTION
- J = 1-1/2" SAFETY VALVE
- 1-1/4" SAFETY VALVE
- K = 12" X 16" MANHOLE
- 16" NOMINAL FLUE DIAMETER

LEGEND

- BS = BOTH SIDES
- RS = RIGHT SIDE

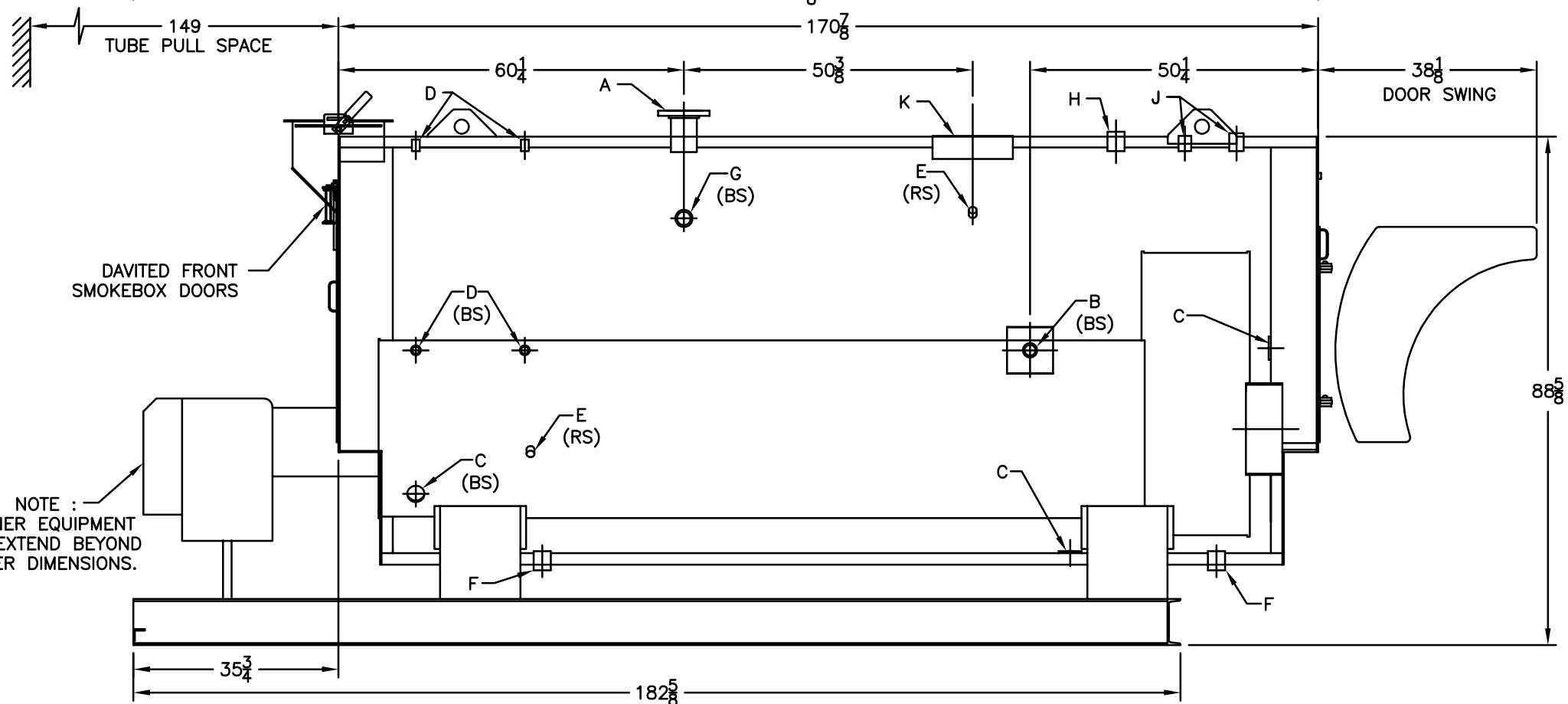
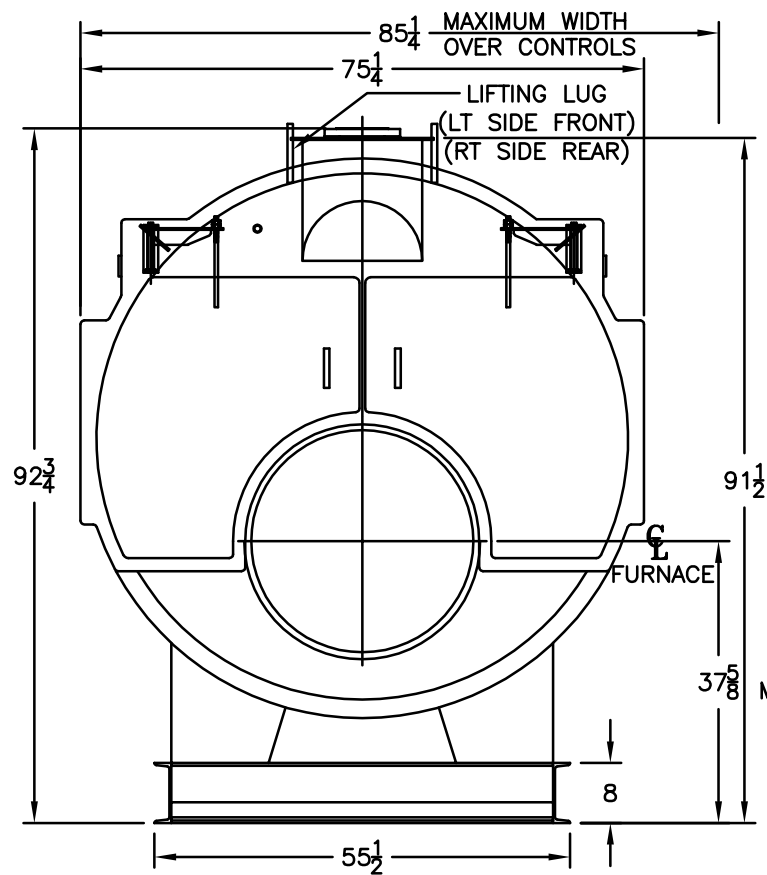
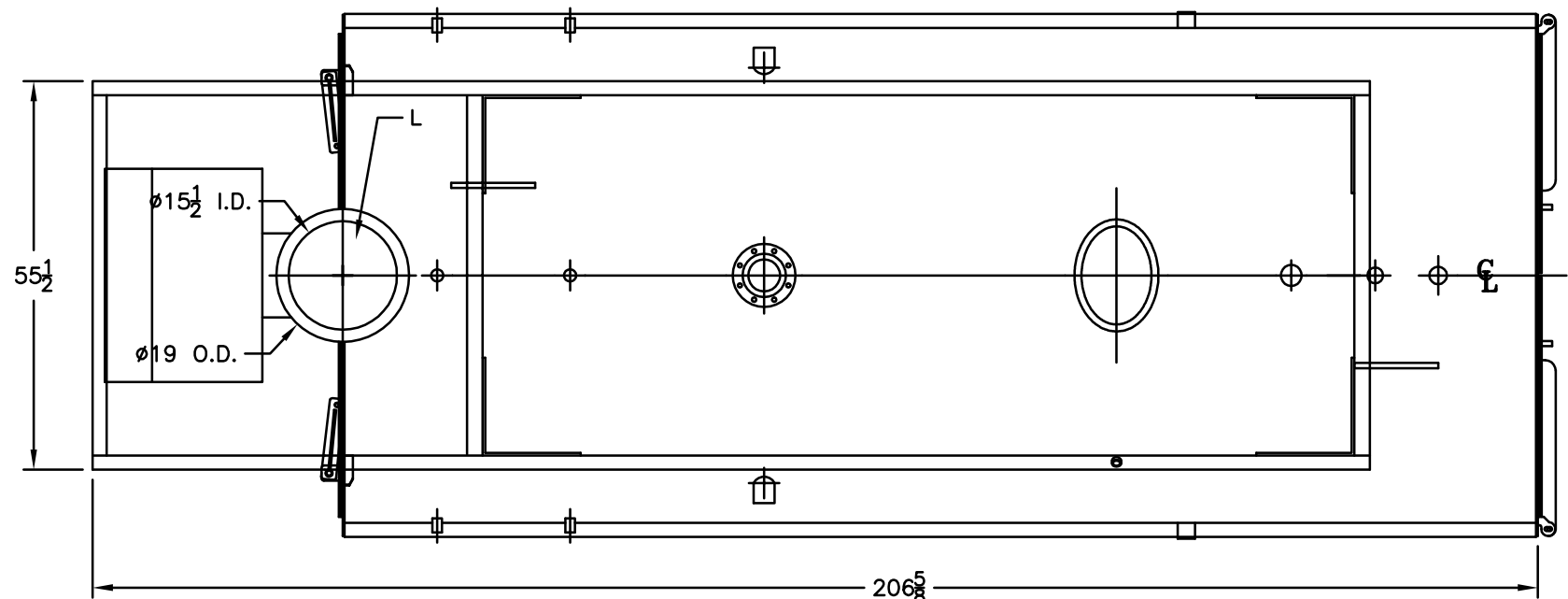

MODEL 4SP-200
200 BHP
150 PSI STEAM

SPECIFICATIONS SUBJECT TO CHANGE WITHOUT NOTICE ALL CONNECTIONS ARE THREADED UNLESS OTHERWISE SPECIFIED
 THIS DOCUMENT CONTAINS CONFIDENTIAL INFORMATION WHICH IS THE PROPERTY OF BURNHAM COMMERCIAL. THIS DOCUMENT MAY NOT BE REPRODUCED, TRANSFERRED OR USED, OR ITS CONTENTS DISCLOSED, WITHOUT THE WRITTEN PERMISSION OF THE OWNER.