

BURNHAM®

Commercial Boilers

RATINGS AND DATA

Shell Diameter : 62"
 Gross Output - BHP : 133
 Gross Output - MBH : 4451
 Net Rating - MBH : 3870
 Safety Valve - Lbs/Hr. : 5000

Heating Surface - Sq. Ft.
 Fireside - 625
 Firetubes
 Number - 86
 Diameter - 2.5" O.D.

Firing Rate
 1000 BTU Gas (MBH) - 5230
 140000 BTU/Gal Oil (GPH) - 36.2
 150000 BTU/Gal Oil (GPH) - 33.8

Water Content
 Pounds - 9200
 Gallons (U.S.) - 1103
 Approximate Weight/LBS.
 Dry - 10900
 Wet - 20100

LEGEND

BS = BOTH SIDES
 RS = RIGHT SIDE

LEGEND CONNECTIONS

- A = 6" FLANGED SUPPLY (150#)
- B = 6" FLANGED RETURN (150#)
- C = 3" x 4" HANDHOLE
- D = 1" WATER COLUMN
- E = 3/4" AQUASTAT
- F = 1-1/2" BOTTOM DRAIN
- G = 1-1/2" AUXILIARY CONNECTION
- H = 3/4" GAUGE CONNECTION
- J = 1" RELIEF VALVE
- K = 12" X 16" MANHOLE
- L = 12" NOMINAL FLUE DIAMETER

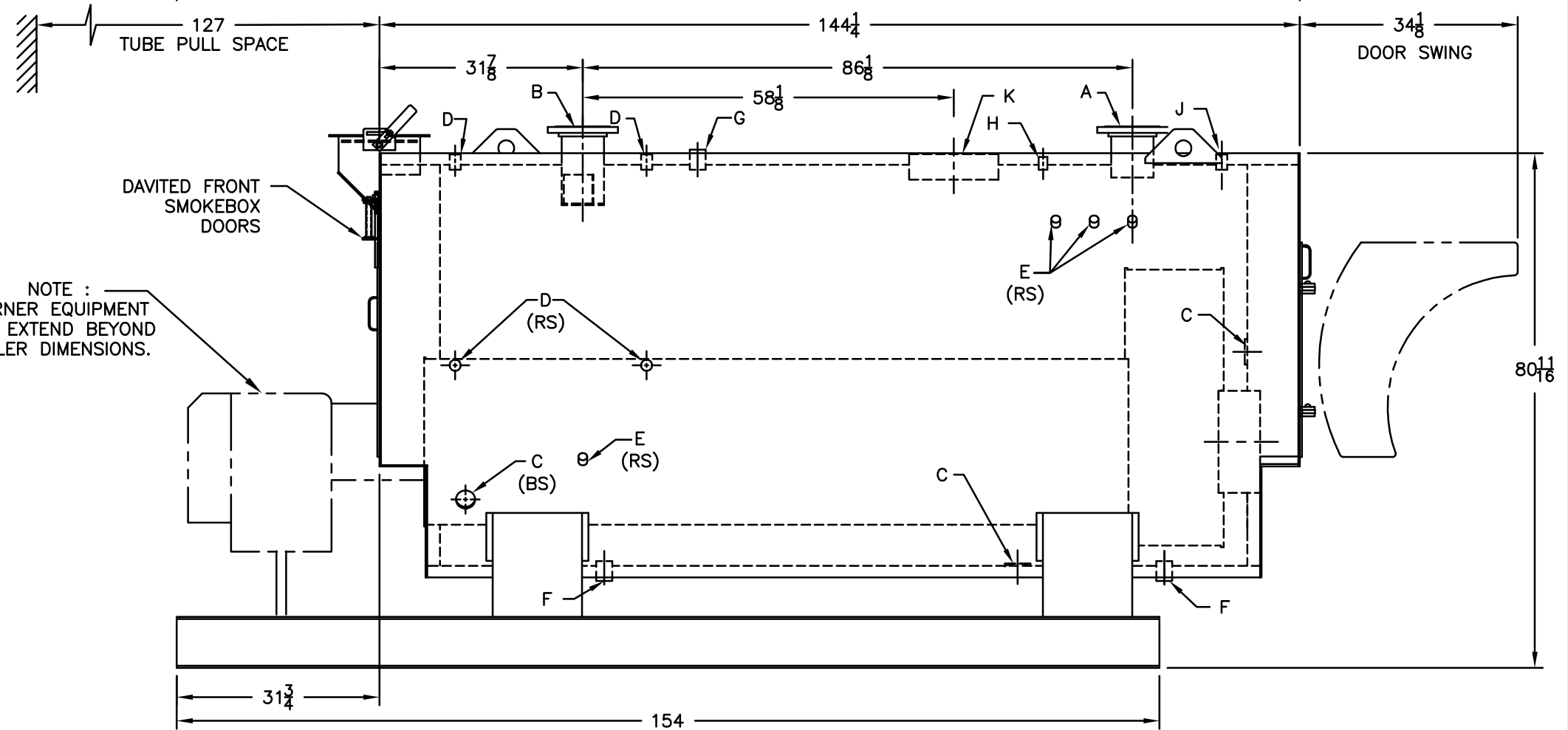
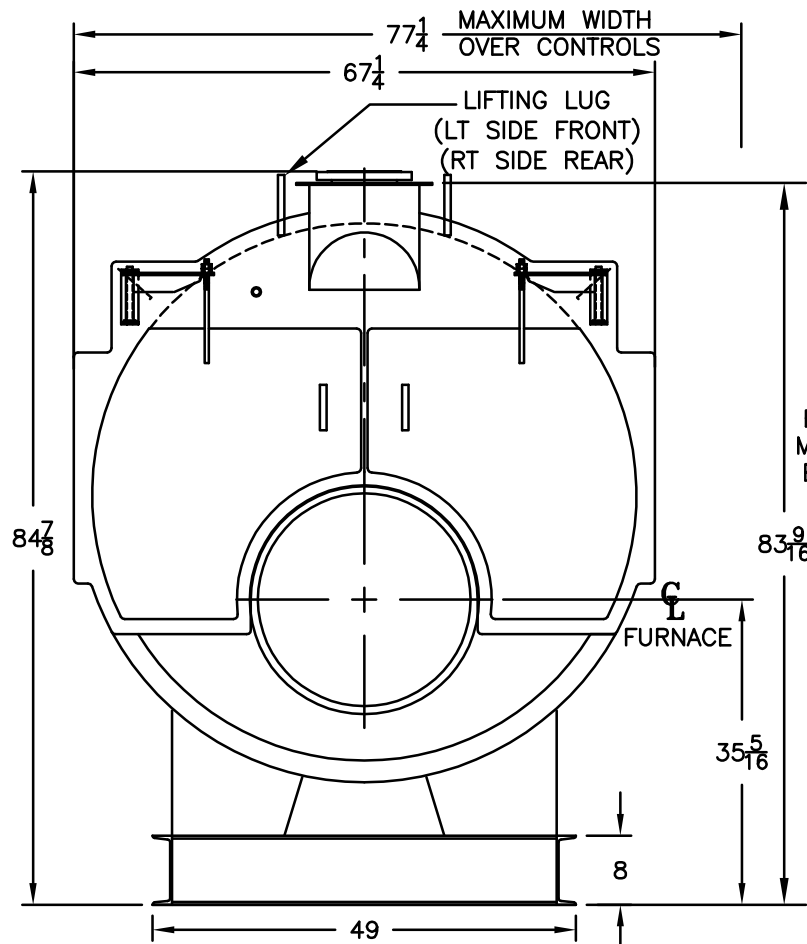
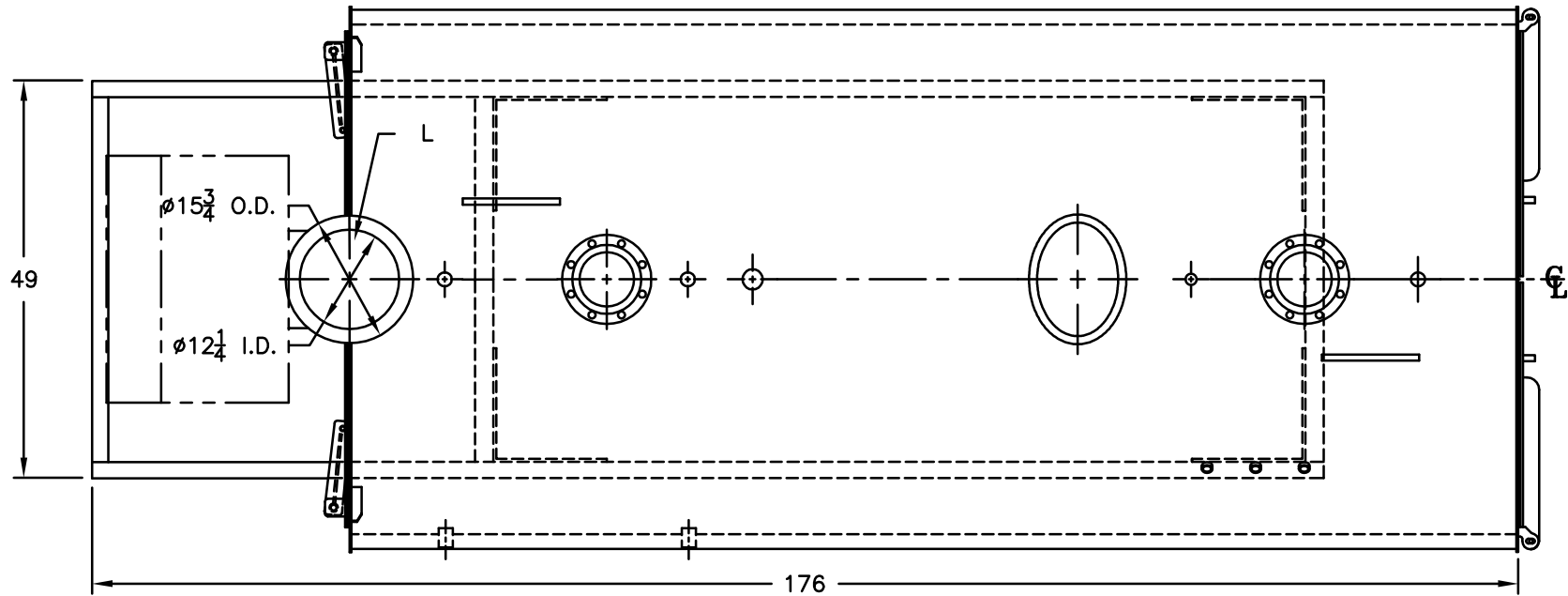

NOTE :
 BURNER EQUIPMENT
 MAY EXTEND BEYOND
 BOILER DIMENSIONS.

SPECIFICATIONS SUBJECT TO CHANGE WITHOUT NOTICE
 ALL CONNECTIONS ARE THREADED UNLESS OTHERWISE SPECIFIED

MODEL 4SPW-125
133 BHP
125 PSI WATER