

BURNHAM®

Commercial Boilers

RATINGS AND DATA

Shell Diameter : 70"
 Gross Output - BHP : 186.4
 Gross Output - MBH : 6239
 Net Rating - MBH : 5425
 Relief Valve - Lbs/Hr. : 7000

Heating Surface - Sq. Ft.
 Fireside - 875
 Firetubes
 Number - 120
 Diameter - 2.5" O.D.

Firing Rate
 1000 BTU Gas (MBH) - 7323
 140000 BTU/Gal Oil (GPH) - 50.6
 150000 BTU/Gal Oil (GPH) - 47.2

Water Content
 Pounds - 11500
 Gallons (U.S.) - 1379
 Approximate Weight/LBS.
 Dry - 13700
 Wet - 25200

LEGEND

BS = BOTH SIDES
 RS = RIGHT SIDE

LEGEND CONNECTIONS

- A = 6" FLANGED SUPPLY (150#)
- B = 6" FLANGED RETURN (150#)
- C = 3" x 4" HANDHOLE
- D = 1" WATER COLUMN
- E = 3/4" AQUASTAT
- F = 2" BOTTOM DRAIN
- G = 2" AUXILIARY CONNECTION
- H = 3/4" GAUGE CONNECTION
- J = 2" RELIEF VALVE
- 1-1/2" RELIEF VALVE
- K = 12" X 16" MANHOLE
- L = 16" NOMINAL FLUE DIAMETER

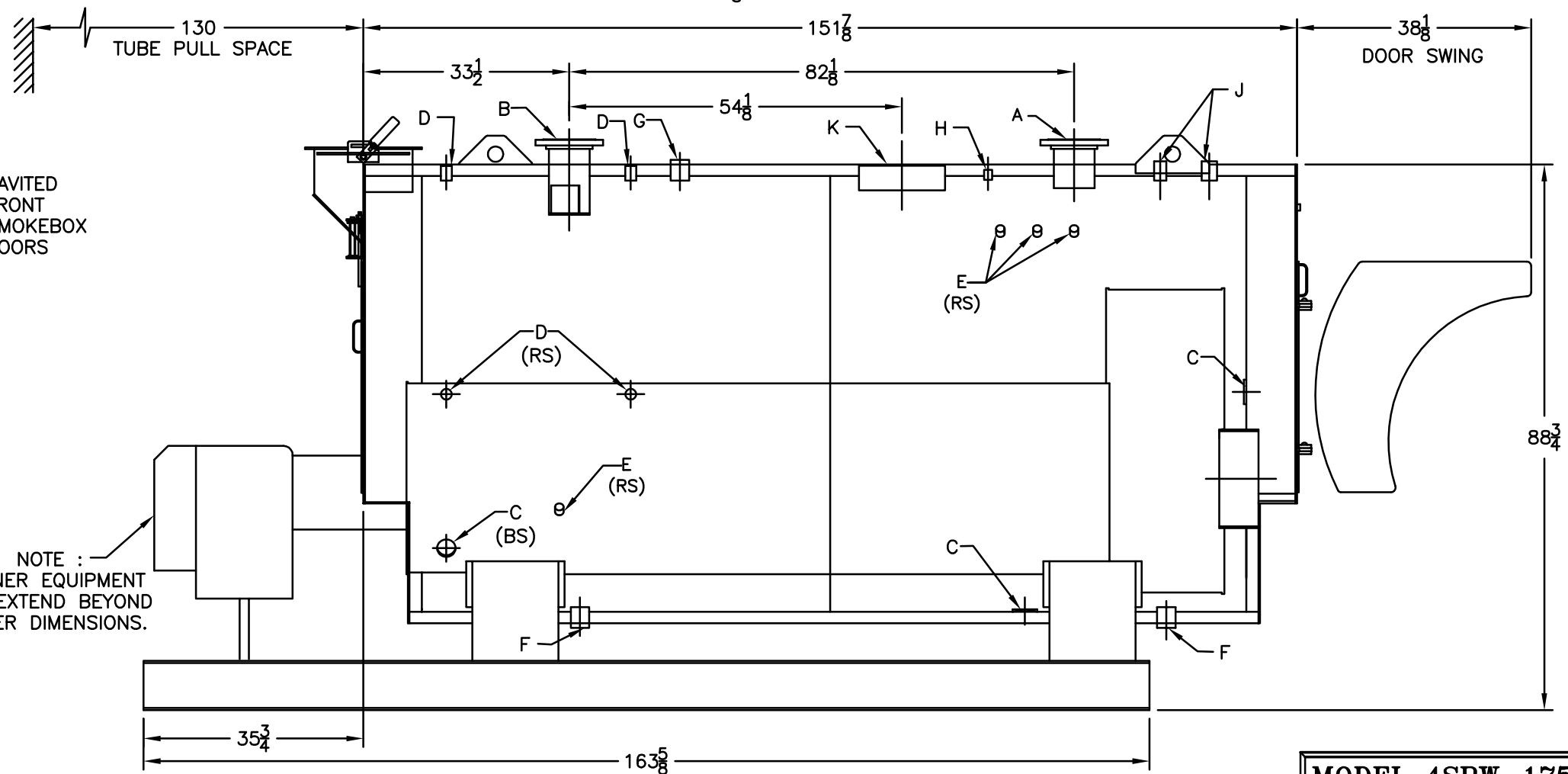
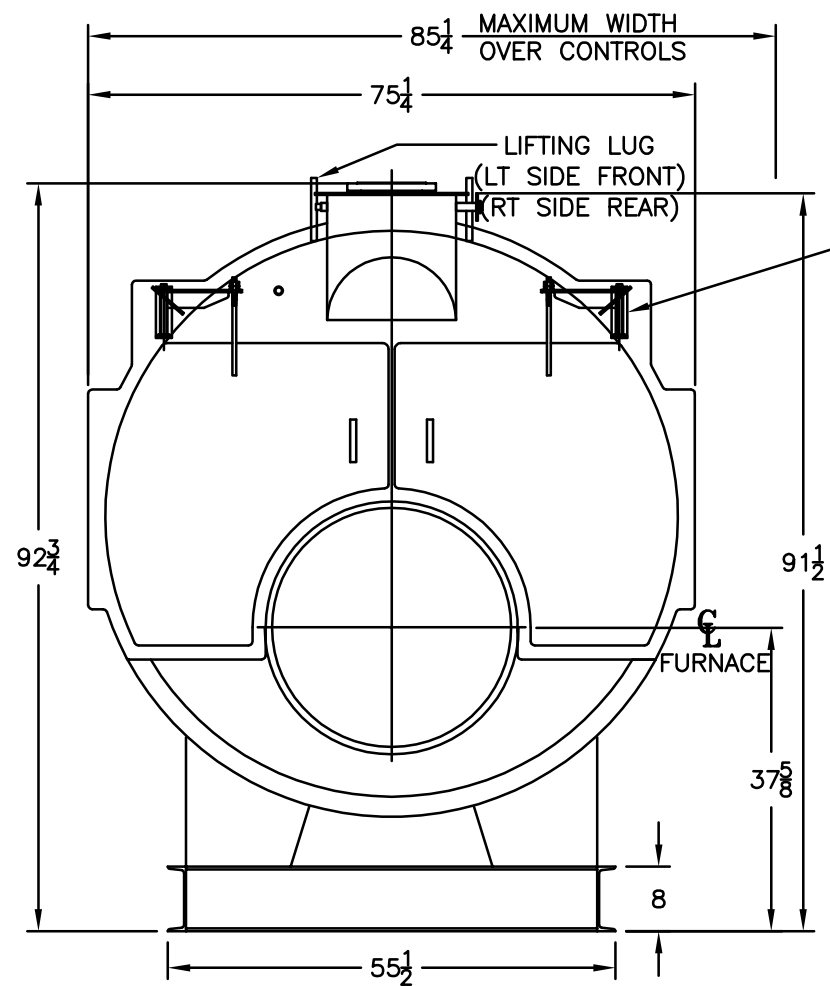
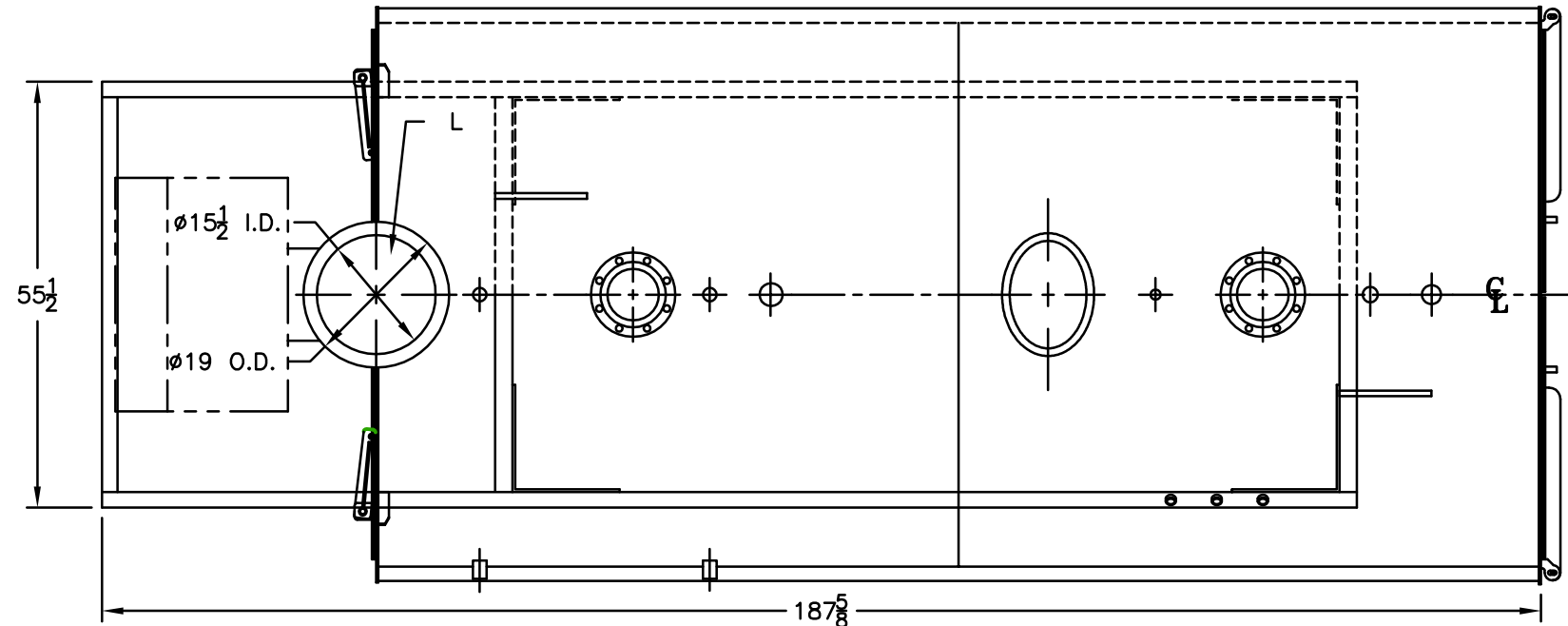

DAVIT FRONT SMOKEBOX DOORS

NOTE :
 BURNER EQUIPMENT
 MAY EXTEND BEYOND
 BOILER DIMENSIONS.

SPECIFICATIONS SUBJECT TO CHANGE WITHOUT NOTICE
 ALL CONNECTIONS ARE THREADED UNLESS OTHERWISE SPECIFIED

MODEL 4SPW-175
186.4 BHP
125 PSI WATER