

# BURNHAM®

## Commercial Boilers

### RATINGS AND DATA

Shell Diameter : 80"  
 Gross Output - BHP : 322.5  
 Gross Output - MBH : 10796  
 Net Rating - MBH : 9387  
 Relief Valve - Lbs/Hr. : 12000

Heating Surface - Sq. Ft.  
 Fireside - 1500  
 Firetubes  
 Number - 164  
 Diameter - 2.5" O.D.

Firing Rate  
 1000 BTU Gas (MBH) - 12553  
 140000 BTU/Gal Oil (GPH) - 86.9  
 150000 BTU/Gal Oil (GPH) - 81.1

Water Content  
 Pounds - 17500  
 Gallons (U.S.) - 2098  
 Approximate Weight/LBS.  
 Dry - 21500  
 Wet - 39000

### LEGEND

BS = BOTH SIDES  
 RS = RIGHT SIDE

### LEGEND CONNECTIONS

- A = 8" FLANGED SUPPLY (150#)
- B = 8" FLANGED RETURN (150#)
- C = 3" x 4" HANDHOLE
- D = 1" WATER COLUMN
- E = 3/4" AQUASTAT
- F = 2" BOTTOM DRAIN
- G = 2" AUXILIARY CONNECTION
- H = 3/4" GAUGE CONNECTION
- J = 2" RELIEF VALVE
- K = 12" X 16" MANHOLE
- L = 20" NOMINAL FLUE DIAMETER

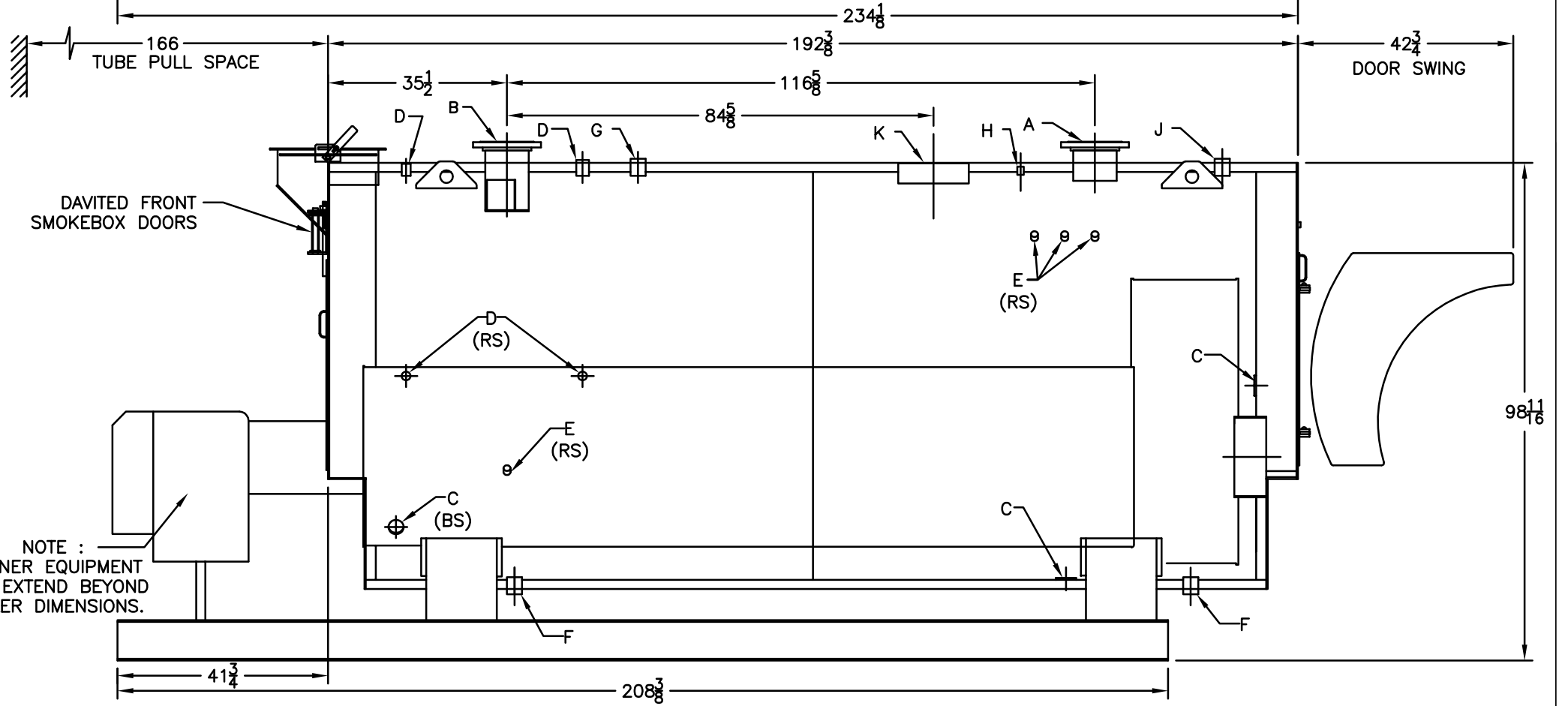
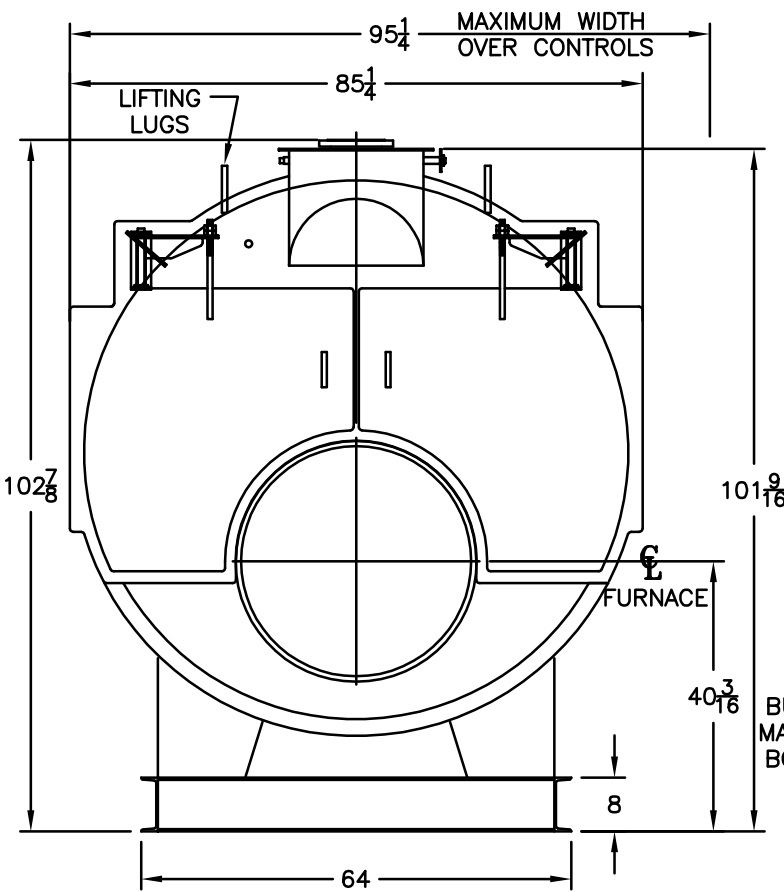
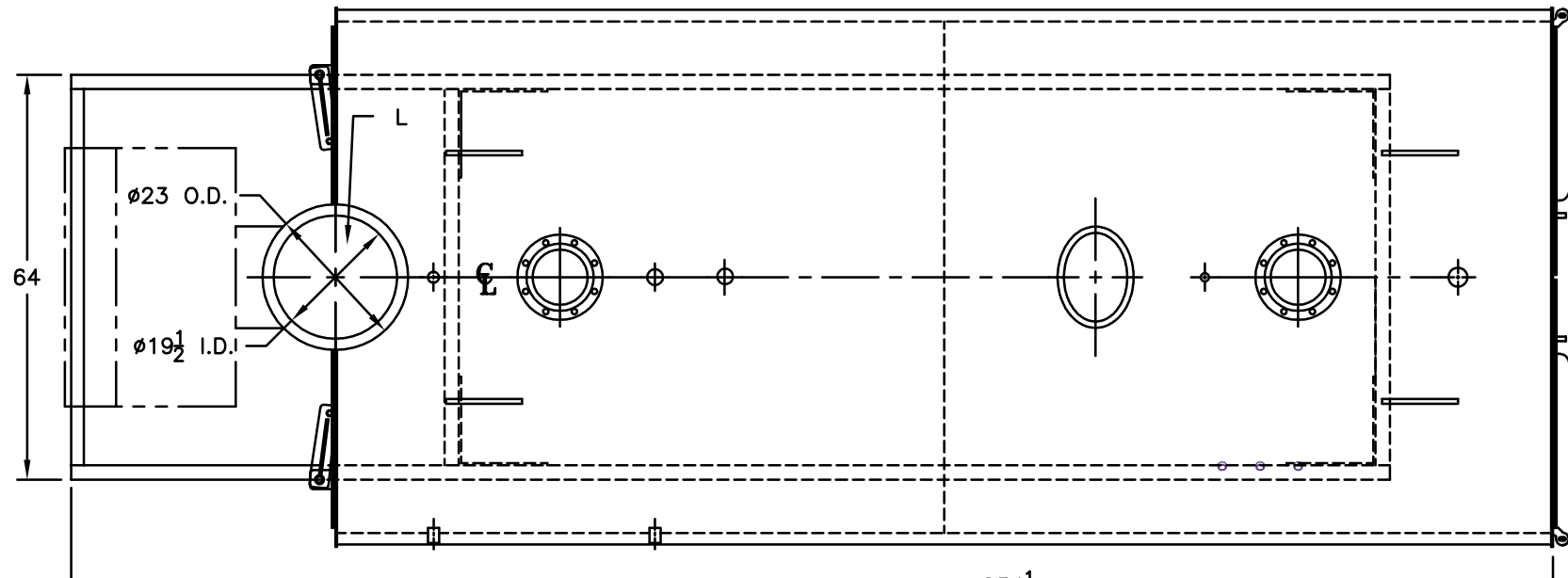

SPECIFICATIONS SUBJECT TO CHANGE WITHOUT NOTICE  
 ALL CONNECTIONS ARE THREADED UNLESS OTHERWISE SPECIFIED

**MODEL 4SPW-300**  
**322.5 BHP**  
**125 PSI WATER**