

BURNHAM®

Commercial Boilers

RATINGS AND DATA

Shell Diameter : 88"
 Gross Output - BHP : 375.8
 Gross Output - MBH : 12580
 Net Rating - MBH : 10939
 Relief Valve - Lbs/Hr. : 14000

Heating Surface - Sq. Ft.
 Fireside - 1750
 Firetubes
 Number - 200
 Diameter - 2.5" O.D.

Firing Rate
 1000 BTU Gas (MBH) - 14645
 140000 BTU/Gal Oil (GPH) - 101.4
 150000 BTU/Gal Oil (GPH) - 94.6

Water Content
 Pounds - 22100
 Gallons (U.S.) - 2649
 Approximate Weight/LBS.
 Dry - 26100
 Wet - 48200

LEGEND CONNECTIONS

- A = 8" FLANGED SUPPLY (150#)
- B = 8" FLANGED RETURN (150#)
- C = 3" x 4" HANDHOLE
- D = 1" WATER COLUMN
- E = 3/4" AQUASTAT
- F = 2" BOTTOM DRAIN
- G = 2" AUXILIARY CONNECTION
- H = 3/4" GAUGE CONNECTION
- J = 2" RELIEF VALVE
- K = 12" X 16" MANHOLE
- L = 24" NOMINAL FLUE DIAMETER

LEGEND

- BS = BOTH SIDES
- RS = RIGHT SIDE

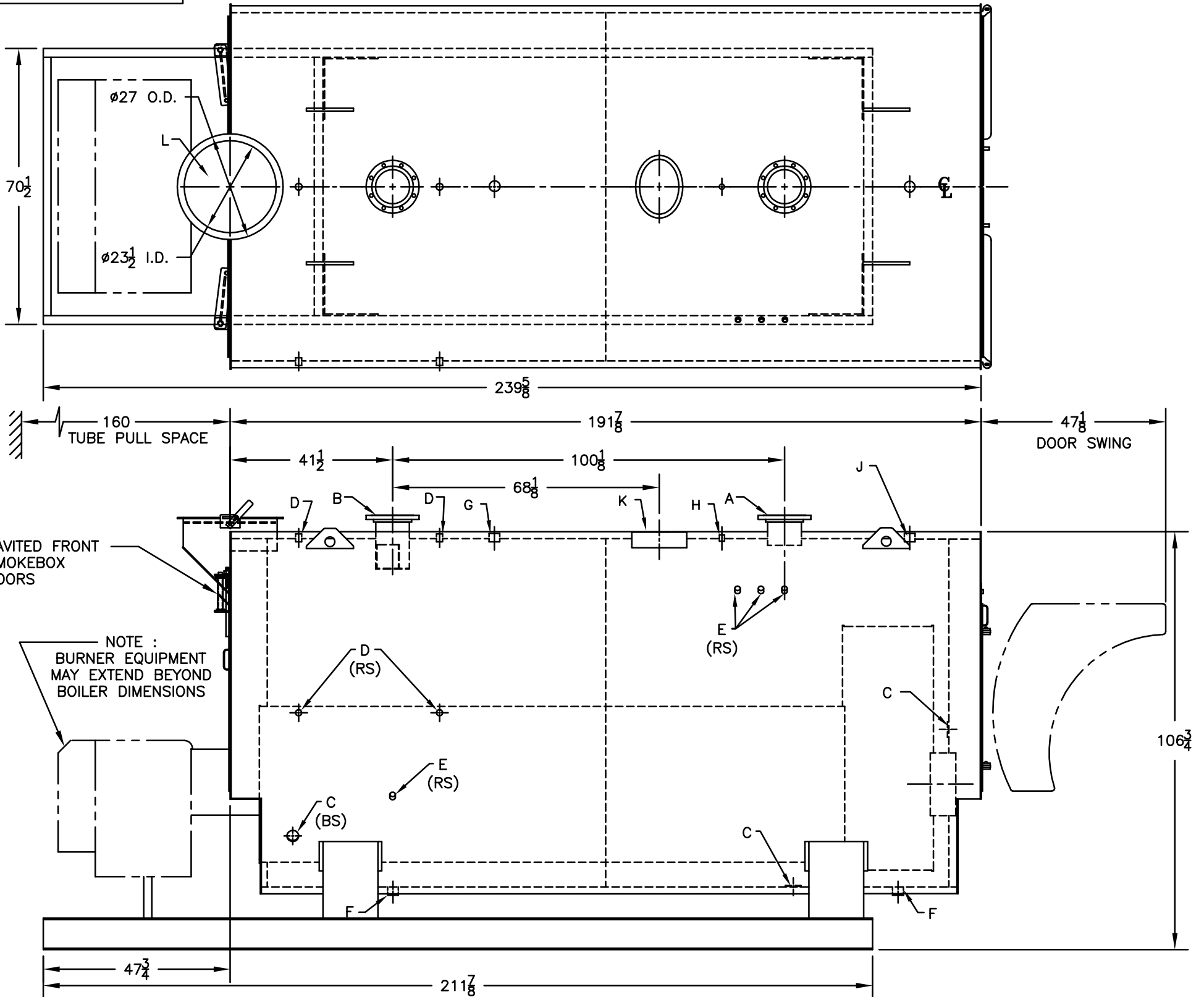
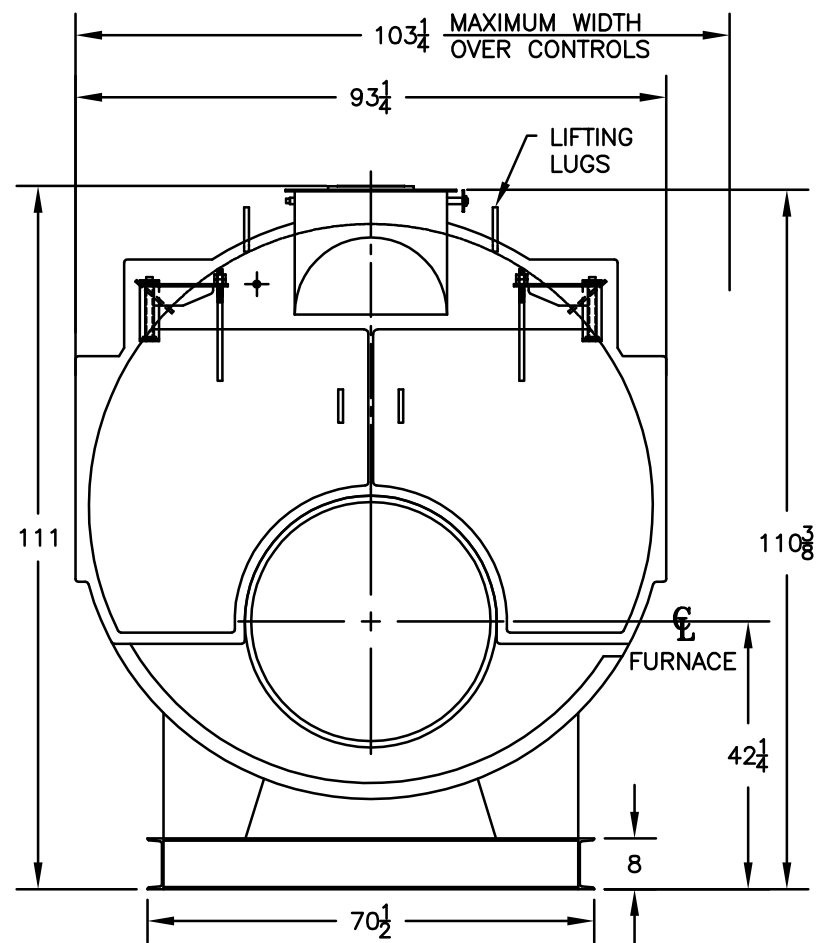

SPECIFICATIONS SUBJECT TO CHANGE WITHOUT NOTICE
 ALL CONNECTIONS ARE THREADED UNLESS OTHERWISE SPECIFIED

MODEL 4SPW-350
375.8 BHP
125 PSI WATER