

# BURNHAM®

## Commercial Boilers

### RATINGS AND DATA

Shell Diameter : 98"  
 Gross Output - BHP : 649.5  
 Gross Output - MBH : 21742  
 Net Rating - MBH : 18906  
 Relief Valve - Lbs/Hr. : 24000

Heating Surface - Sq. Ft.  
 Fireside - 3000  
 Firetubes  
 Number - 264  
 Diameter - 2.5" O.D.

Firing Rate  
 1000 BTU Gas (MBH) - 25106  
 140000 BTU/Gal Oil (GPH) - 173.9  
 150000 BTU/Gal Oil (GPH) - 162.3

Water Content  
 Pounds - 35400  
 Gallons (U.S.) - 4244  
 Approximate Weight/LBS.  
 Dry - 38700  
 Wet - 74100

### LEGEND CONNECTIONS

- A = 8" FLANGED SUPPLY (150#)
- B = 8" FLANGED RETURN (150#)
- C = 3" x 4" HANDHOLE
- D = 1" WATER COLUMN
- E = 3/4" AQUASTAT
- F = 2" BOTTOM DRAIN
- G = 2" AUXILIARY CONNECTION
- H = 3/4" GAUGE CONNECTION
- J = 1-1/2" RELIEF VALVE (1)  
2" RELIEF VALVE (1)
- K = 12" X 16" MANHOLE
- L = 28" NOMINAL FLUE DIAMETER

### LEGEND

- BS = BOTH SIDES
- RS = RIGHT SIDE

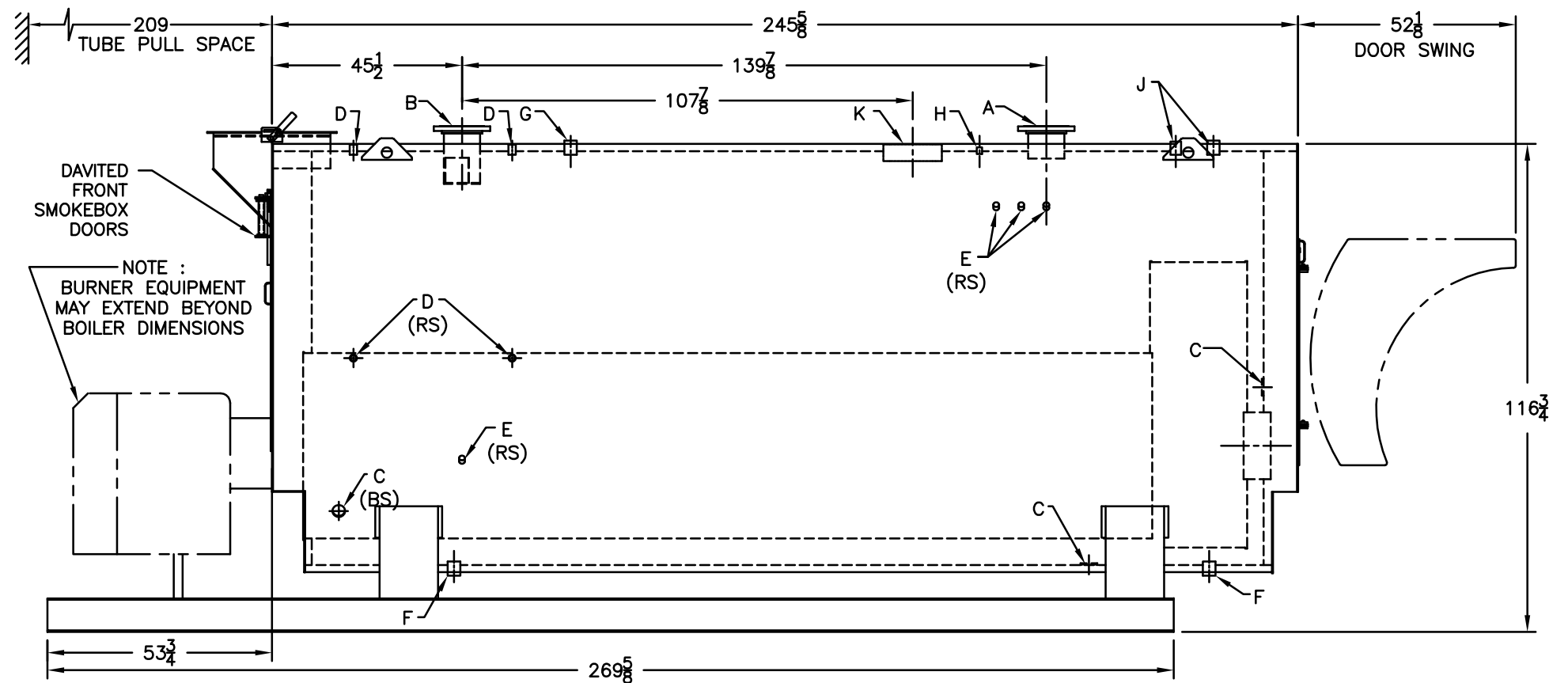
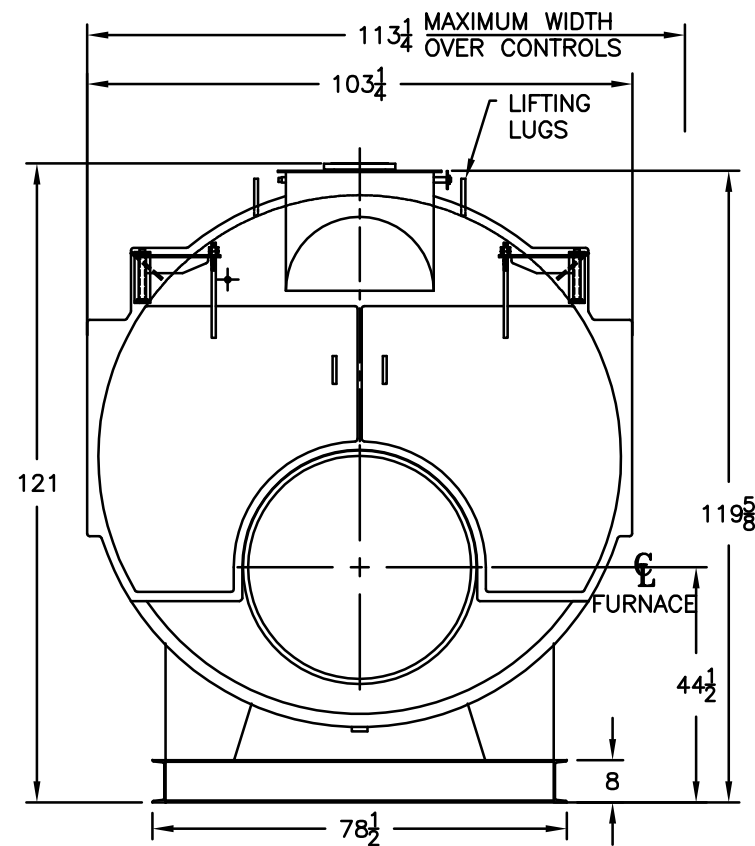
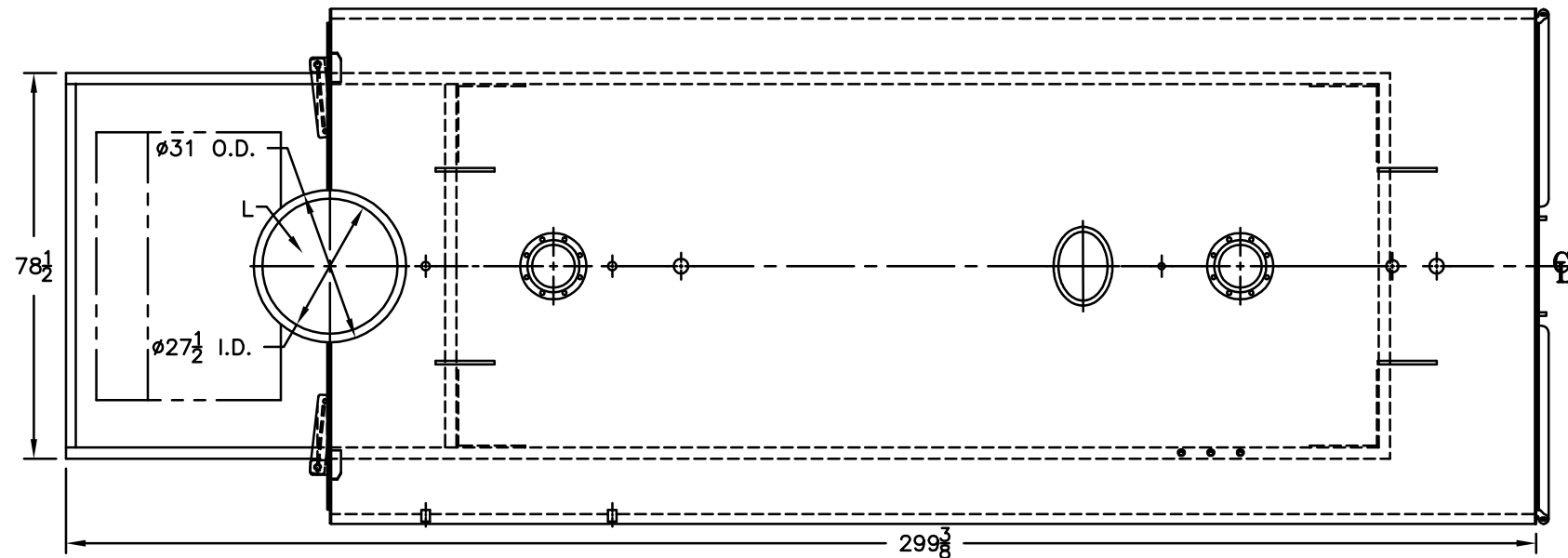

SPECIFICATIONS SUBJECT TO CHANGE WITHOUT NOTICE  
 ALL CONNECTIONS ARE THREADED UNLESS OTHERWISE SPECIFIED

**MODEL 4SPW-600**  
**649.5 BHP**  
**125 PSI WATER**