

BURNHAM®

Commercial Boilers

RATINGS AND DATA

Shell Diameter : 108"
 Gross Output - BHP : 755.1
 Gross Output - MBH : 25278
 Net Rating - MBH : 21981
 Relief Valve - Lbs/Hr. : 28000

Heating Surface - Sq. Ft.
 Fireside - 3500
 Firetubes
 Number - 348
 Diameter - 2.5" O.D.

Firing Rate
 1000 BTU Gas (MBH) - 29291
 140000 BTU/Gal Oil (GPH) - 202.6
 150000 BTU/Gal Oil (GPH) - 189.1

Water Content
 Pounds - 39400
 Gallons (U.S.) - 4723
 Approximate Weight/LBS.
 Dry - 46700
 Wet - 86100

LEGEND CONNECTIONS

- A = 10" FLANGED SUPPLY (150#)
- B = 10" FLANGED RETURN (150#)
- C = 3" x 4" HANDHOLE
- D = 1" WATER COLUMN
- E = 3/4" AQUASTAT
- F = 2" BOTTOM DRAIN
- G = 2" AUXILIARY CONNECTION
- H = 3/4" GAUGE CONNECTION
- J = 2" RELIEF VALVE (1)
 1-1/2" RELIEF VALVE (1)
- K = 12" X 16" MANHOLE
- L = 28" NOMINAL FLUE DIAMETER

LEGEND

- BS = BOTH SIDES
- RS = RIGHT SIDE

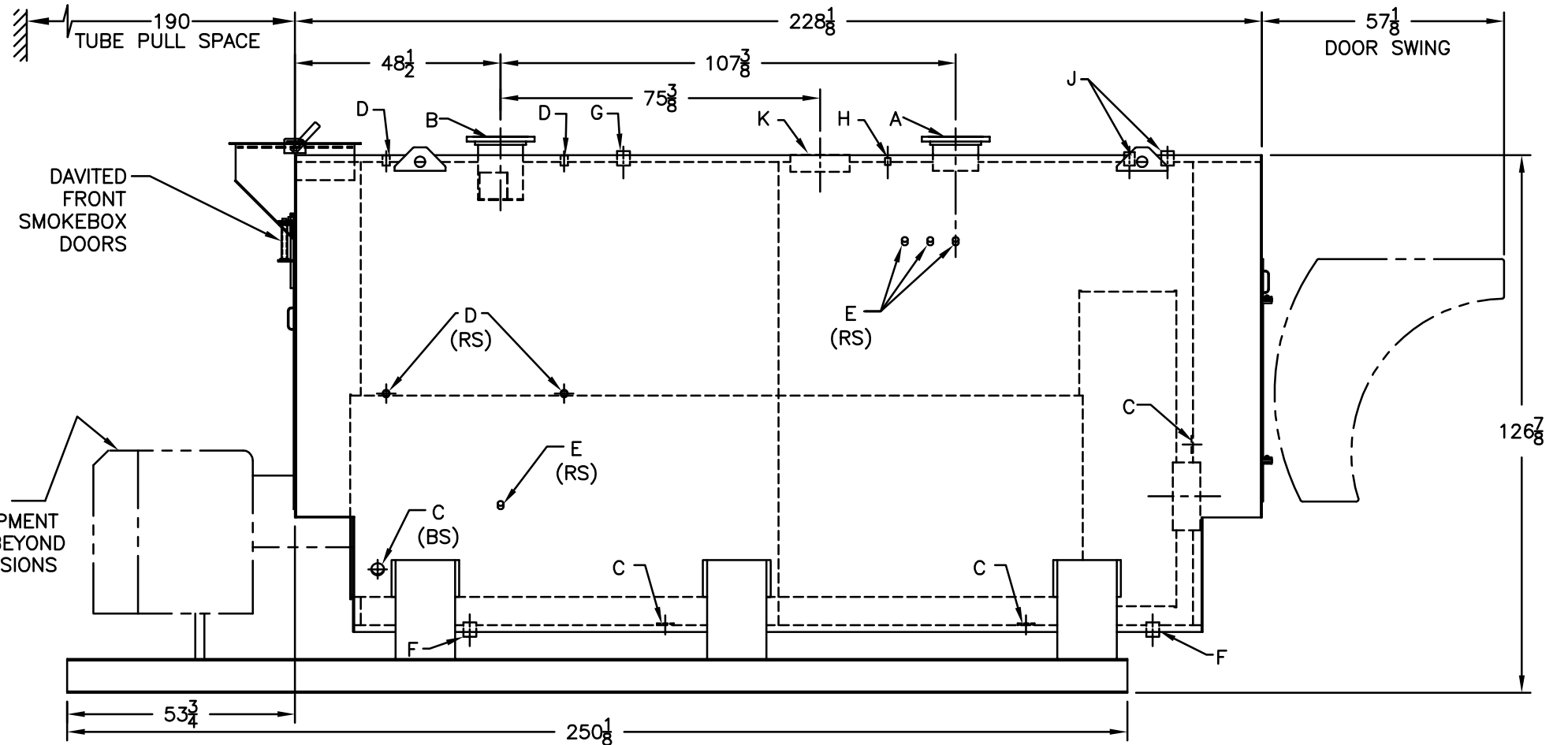
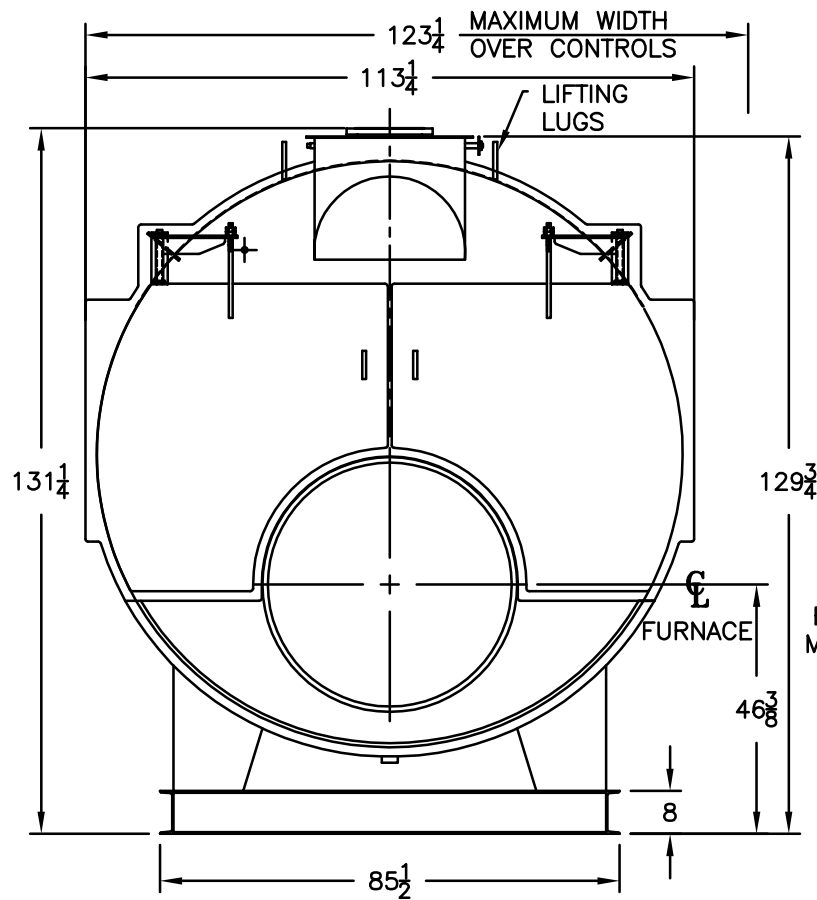
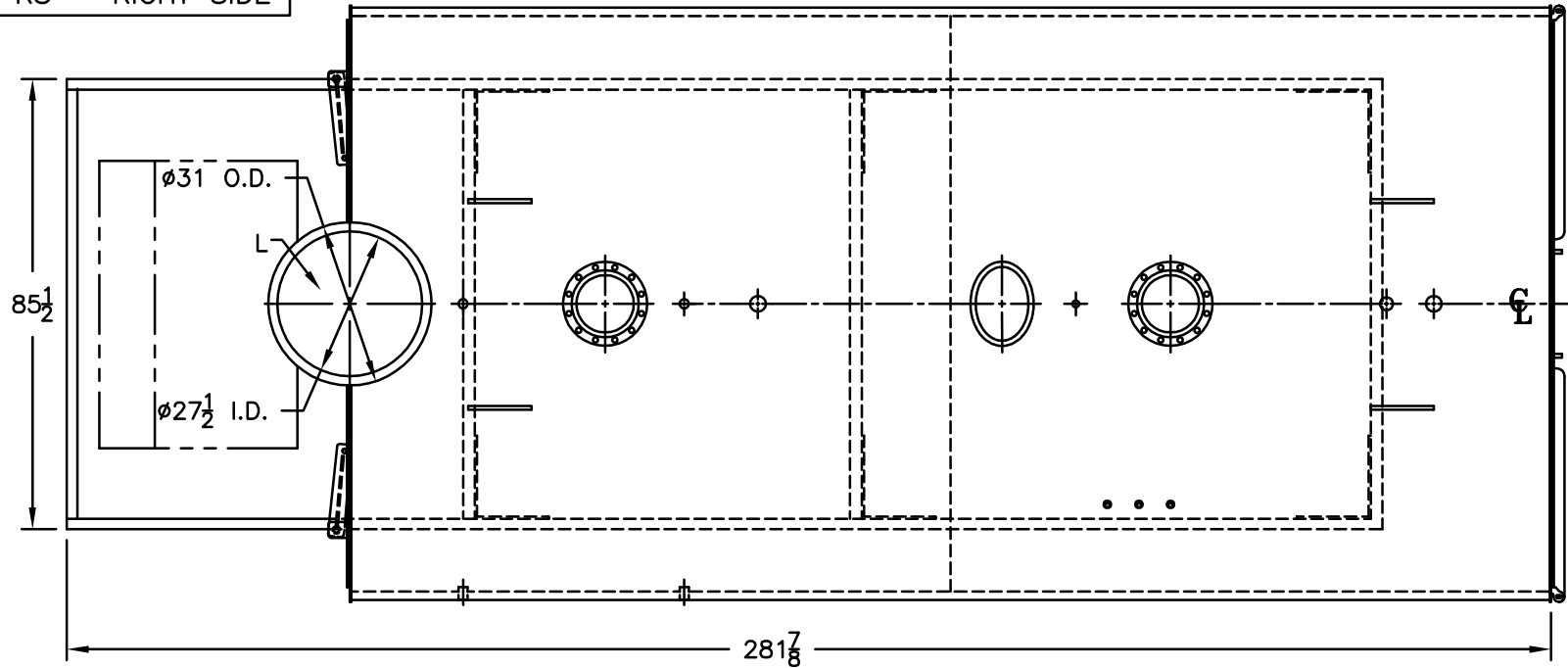

NOTE :
 BURNER EQUIPMENT
 MAY EXTEND BEYOND
 BOILER DIMENSIONS

SPECIFICATIONS SUBJECT TO CHANGE WITHOUT NOTICE
 ALL CONNECTIONS ARE THREADED UNLESS OTHERWISE SPECIFIED

MODEL 4SPW-700
755.1 BHP
125 PSI WATER