

BURNHAM®

Commercial Boilers

RATINGS AND DATA

Shell Diameter : 88"
 Gross Output - BHP : 431.5
 Gross Output - MBH : 14445
 Net Rating - MBH : 12561
 Safety Valve - Lbs/Hr. : 16000

Heating Surface - Sq. Ft.
 Fireside - 2000
 Firetubes
 Number - 200
 Diameter - 2.5" O.D.

Firing Rate
 1000 BTU Gas (MBH) - 16738
 140000 BTU/Gal Oil (GPH) - 115.9
 150000 BTU/Gal Oil (GPH) - 108.2

Water Content
 Pounds - 25418
 Gallons (U.S.) - 3047
 Approximate Weight/LBS.
 Dry - 25424
 Wet - 50843

LEGEND CONNECTIONS

- A = 8" FLANGED SUPPLY (150#)
- B = 8" FLANGED RETURN (150#)
- C = 3" x 4" HANDHOLE
- D = 1" WATER COLUMN
- E = 3/4" AQUASTAT
- F = 2" BOTTOM DRAIN
- G = 2" AUXILIARY
- H = 3/4" GAUGE CONNECTION
- J = 2" RELIEF VALVE (3)
- K = 12" X 16" MANHOLE
- L = 24" NOMINAL FLUE DIAMETER

LEGEND

- BS = BOTH SIDES
- RS = RIGHT SIDE

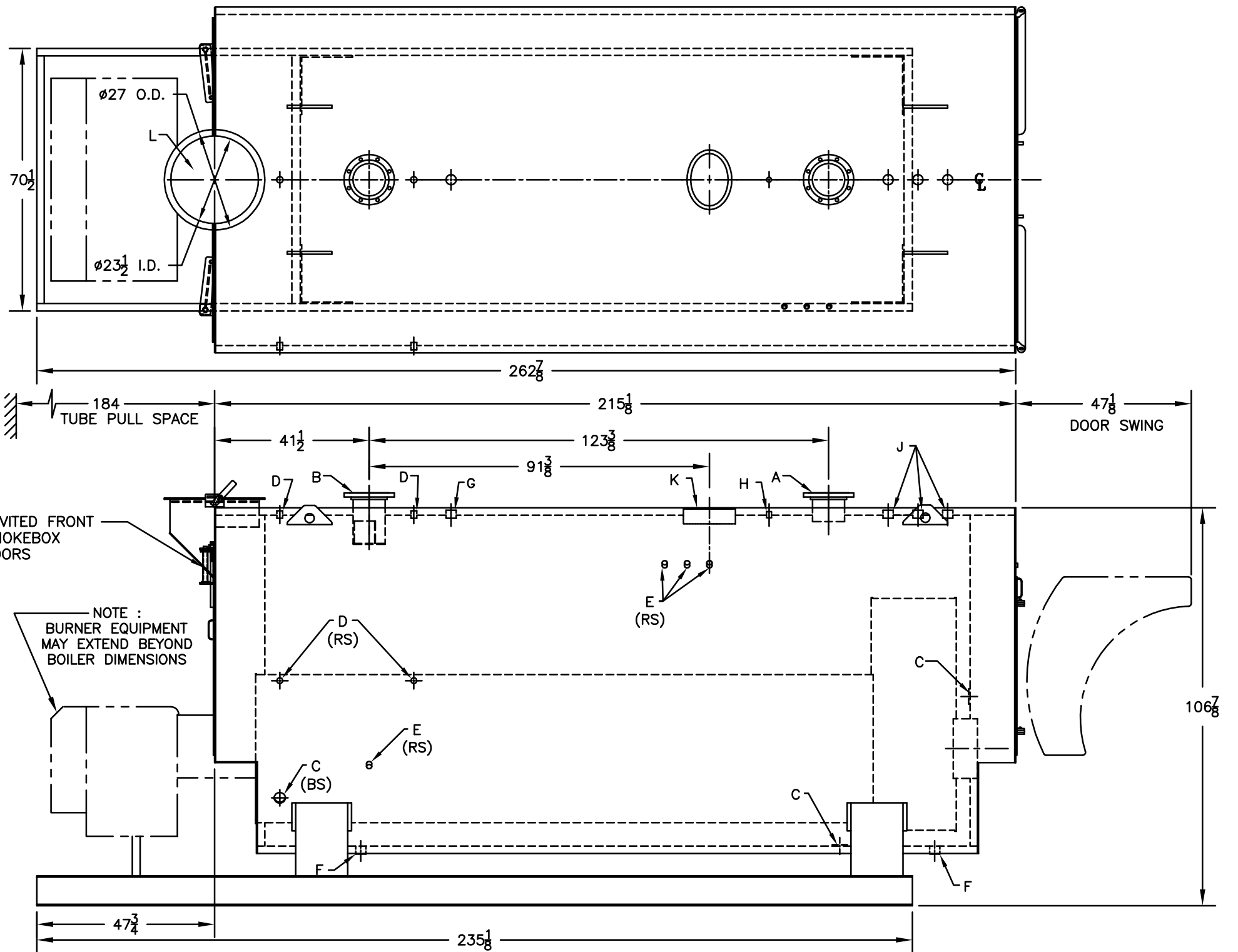
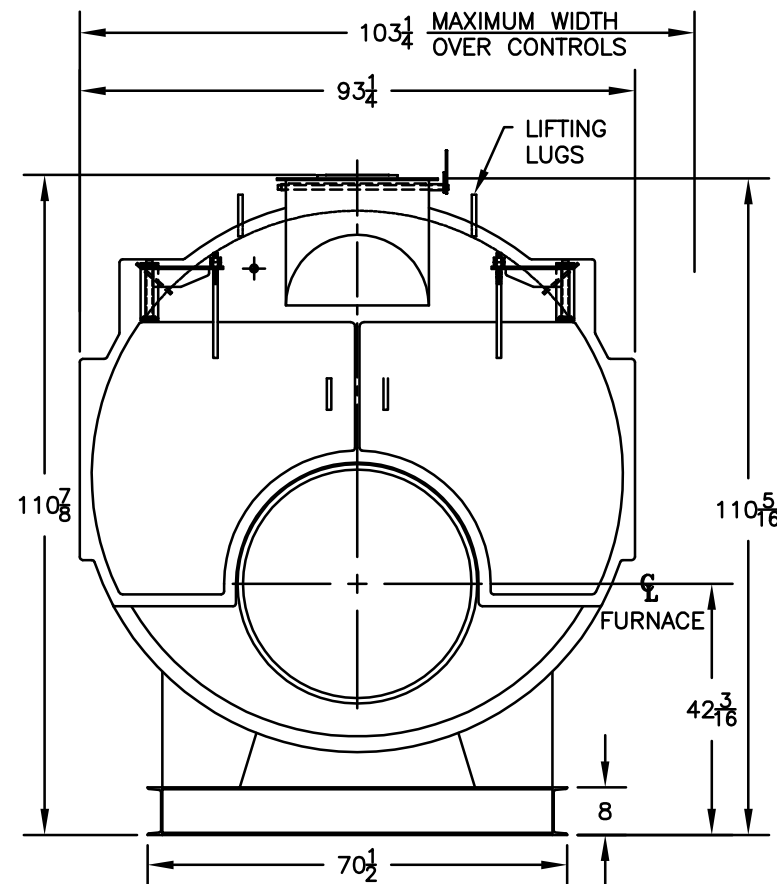

SPECIFICATIONS SUBJECT TO CHANGE WITHOUT NOTICE ALL CONNECTIONS ARE THREADED UNLESS OTHERWISE SPECIFIED
 THIS DOCUMENT CONTAINS CONFIDENTIAL INFORMATION WHICH IS THE PROPERTY OF BURNHAM COMMERCIAL. THIS DOCUMENT MAY NOT BE REPRODUCED, TRANSFERRED OR USED, OR ITS CONTENTS DISCLOSED, WITHOUT THE WRITTEN PERMISSION OF THE OWNER.

MODEL 4SW-400
431.5 BHP
30 PSI WATER