

# BURNHAM®

## Commercial Boilers

### RATINGS AND DATA

Shell Diameter : 48"  
 Gross Output - BHP : 40.5  
 Gross Output - MBH : 1354  
 Gross Output - Lbs/Hr : 1396  
 Net Rating - MBH : 1024  
 Net Rating - Sq. Ft. : 4267  
 Safety Valve - Lbs/Hr. : 1600

Heating Surface - Sq. Ft.  
 Fireside - 200  
 Firetubes  
 Number - 92  
 Diameter - 2" O.D.

Firing Rate  
 1000 BTU Gas (MBH) - 1674  
 140000 BTU/Gal Oil (GPH) - 11.7  
 150000 BTU/Gal Oil (GPH) - 10.9

Water Content  
 Pounds - 1839  
 Gallons (U.S.) - 220  
 Approximate Weight/LBS.  
 Dry - 3920  
 Wet - 5759

### LEGEND

BS = BOTH SIDES  
 RS = RIGHT SIDE

### LEGEND CONNECTIONS

- A = 6" FLANGED SUPPLY (150#)
- B = 3" RETURN
- C = 3" x 4" HANDHOLE
- D = 1" WATER COLUMN
- E = 3/4" AQUASTAT/LFHA
- F = 1-1/2" BOTTOM BLOWDOWN
- G = 1-1/2" SURFACE BLOWOFF
- H = 1-1/2" AUXILIARY CONNECTION
- J = 2" SAFETY VALVE
- K = 10" NOMINAL FLUE DIAMETER

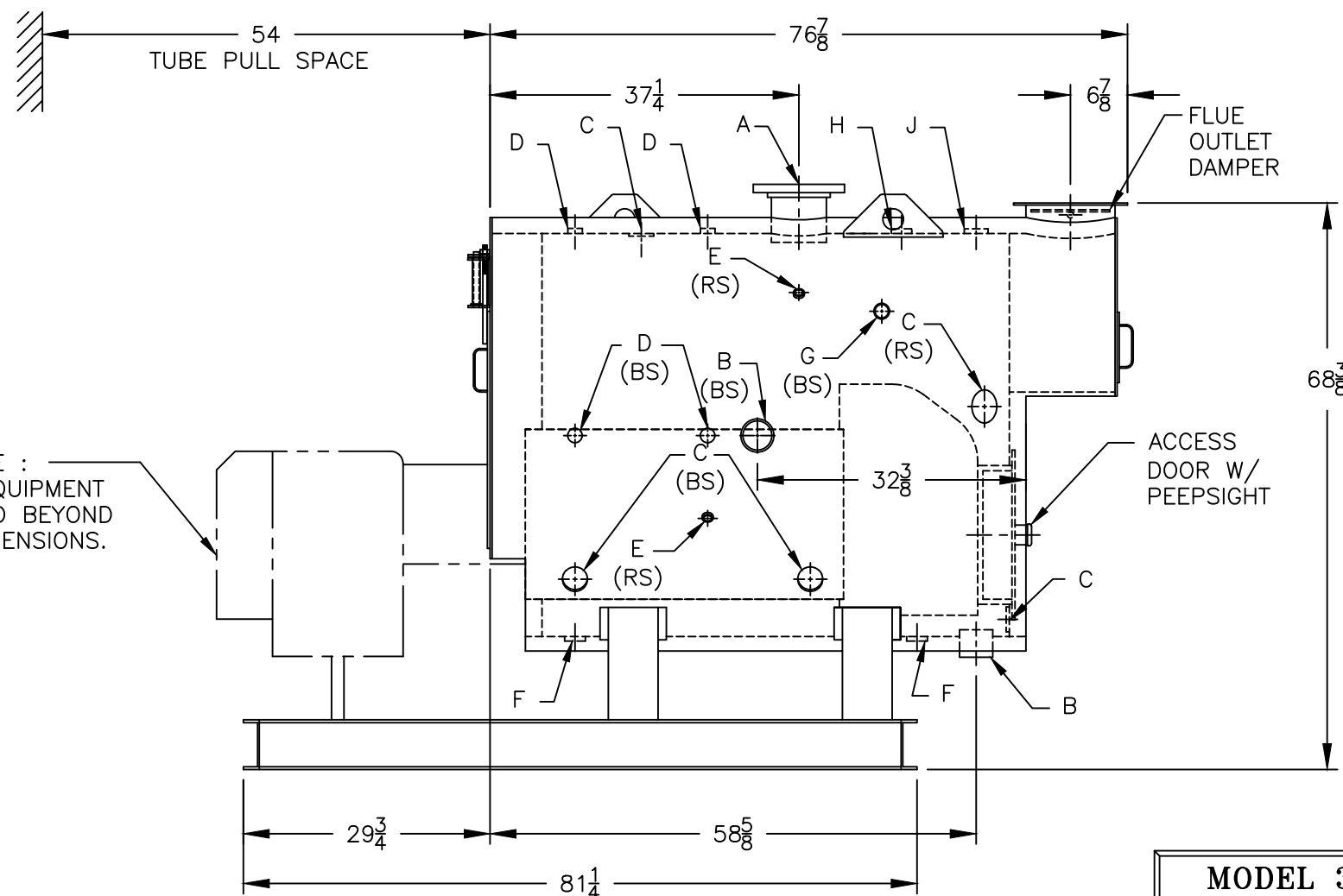
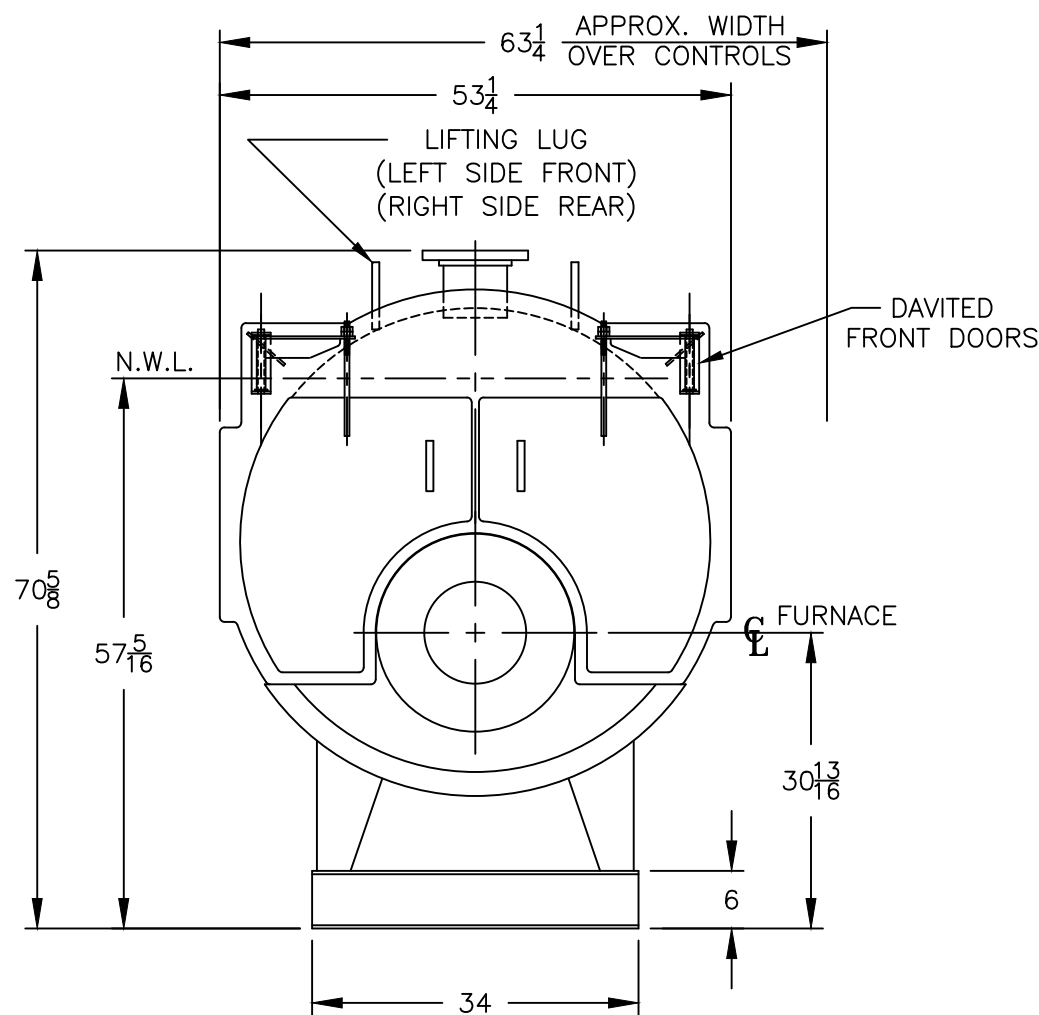
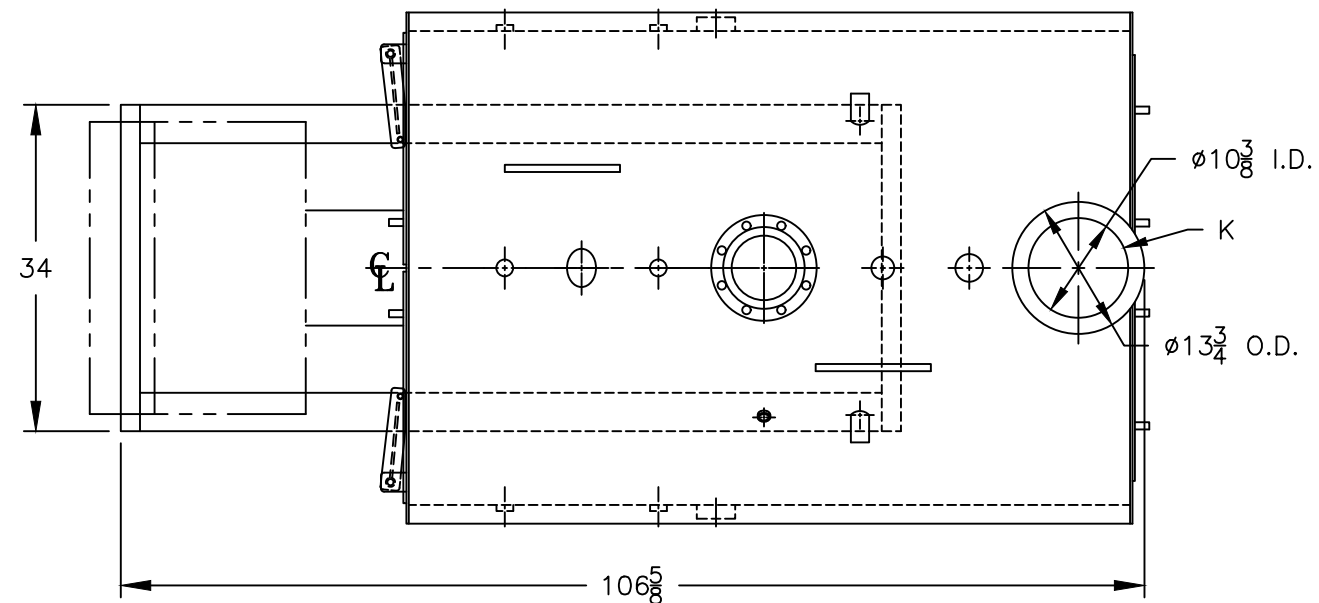

NOTE :  
 BURNER EQUIPMENT  
 MAY EXTEND BEYOND  
 BOILER DIMENSIONS.

**MODEL 3L-40**  
**40.5 BHP**  
**15 PSI STEAM**