

BURNHAM®

Commercial Boilers

LEGEND CONNECTIONS

- A = 8" FLANGED SUPPLY (150#)
- B = 3" RETURN
- C = 3" x 4" HANDHOLE
- D = 1" WATER COLUMN
- E = 3/4" AQUASTAT
- F = 1-1/2" BOTTOM BLOWDOWN
- G = 1-1/2" SURFACE BLOWOFF
- H = 1-1/2" AUXILIARY CONNECTION
- J = 2" SAFETY VALVE
- K = 12" NOMINAL FLUE DIAMETER

RATINGS AND DATA

Shell Diameter : 54"
 Gross Output - BHP : 71.1
 Gross Output - MBH : 2381
 Gross Output - Lbs/Hr : 2455
 Net Rating - MBH : 1849
 Net Rating - Sq. Ft. : 7703
 Safety Valve - Lbs/Hr. : 2800

Heating Surface - Sq. Ft.
 Fireside - 350
 Firetubes
 Number - 106
 Diameter - 2" O.D.

Firing Rate
 1000 BTU Gas (MBH) - 2929
 140000 BTU/Gal Oil (GPH) - 20.1
 150000 BTU/Gal Oil (GPH) - 18.8

Water Content
 Pounds - 3414
 Gallons (U.S.) - 409
 Approximate Weight/LBS.
 Dry - 5500
 Wet - 8914

LEGEND

BS = BOTH SIDES
 RS = RIGHT SIDE

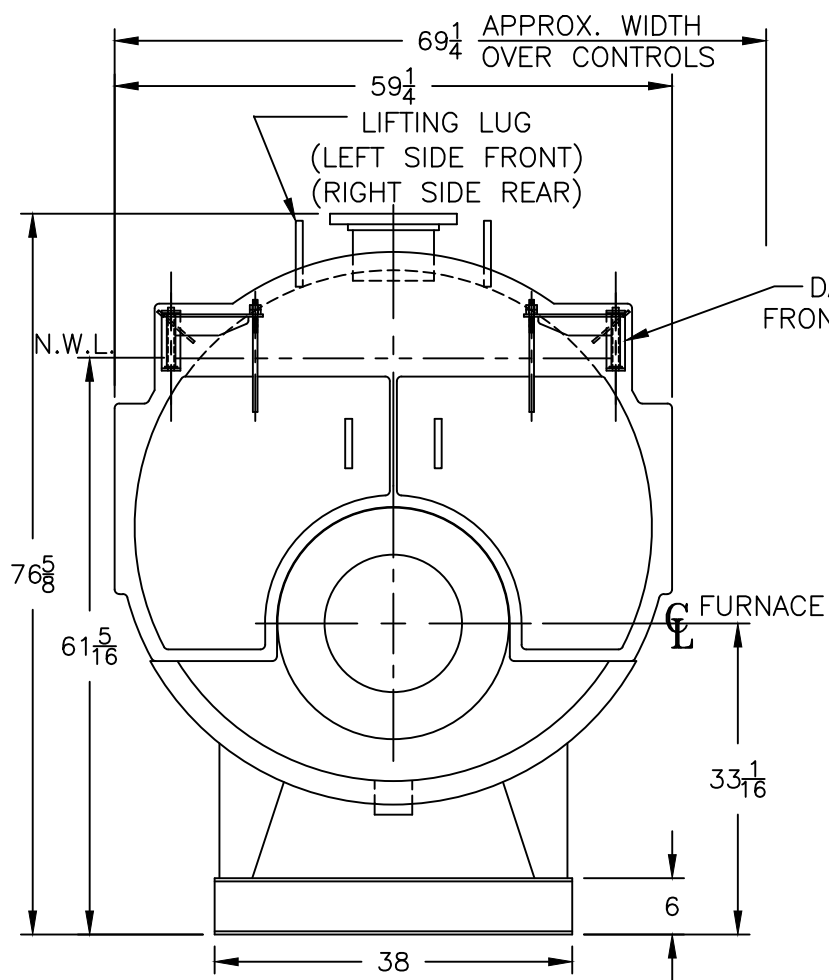
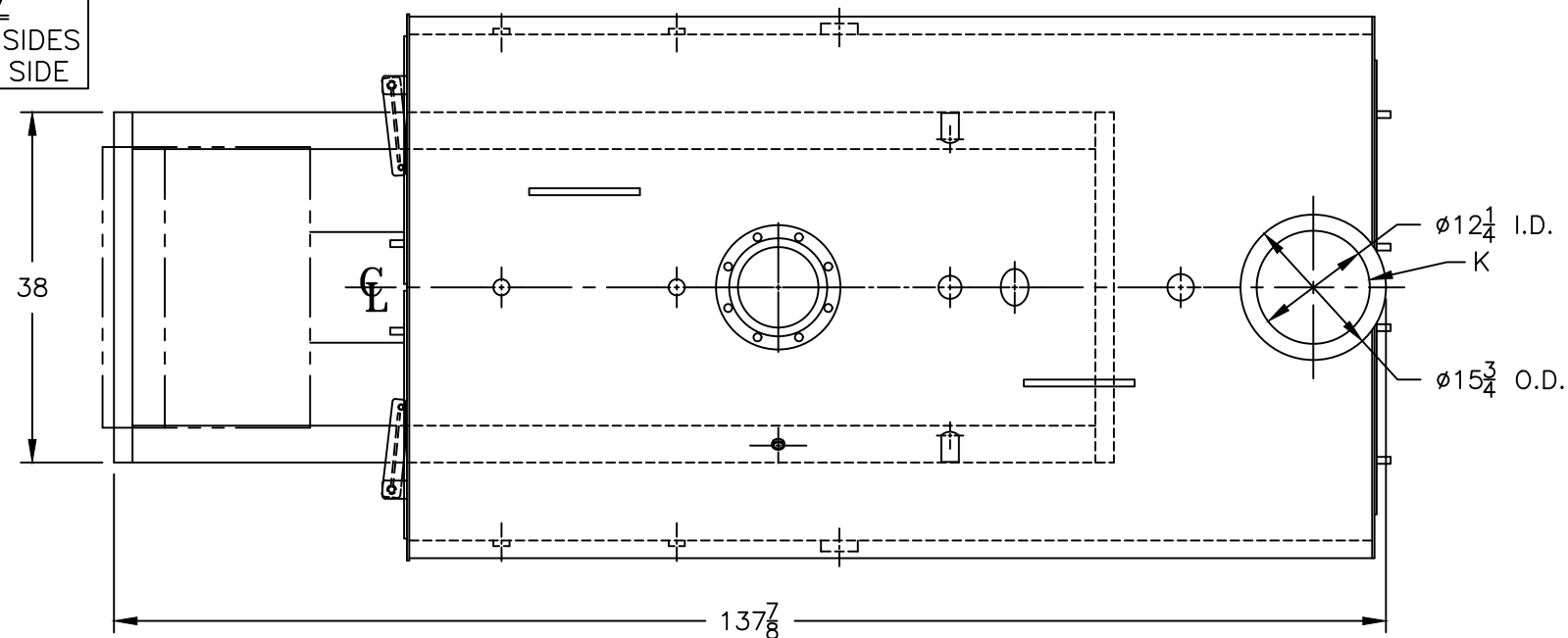

NOTE :
 BURNER EQUIPMENT
 MAY EXTEND BEYOND
 BOILER DIMENSIONS.

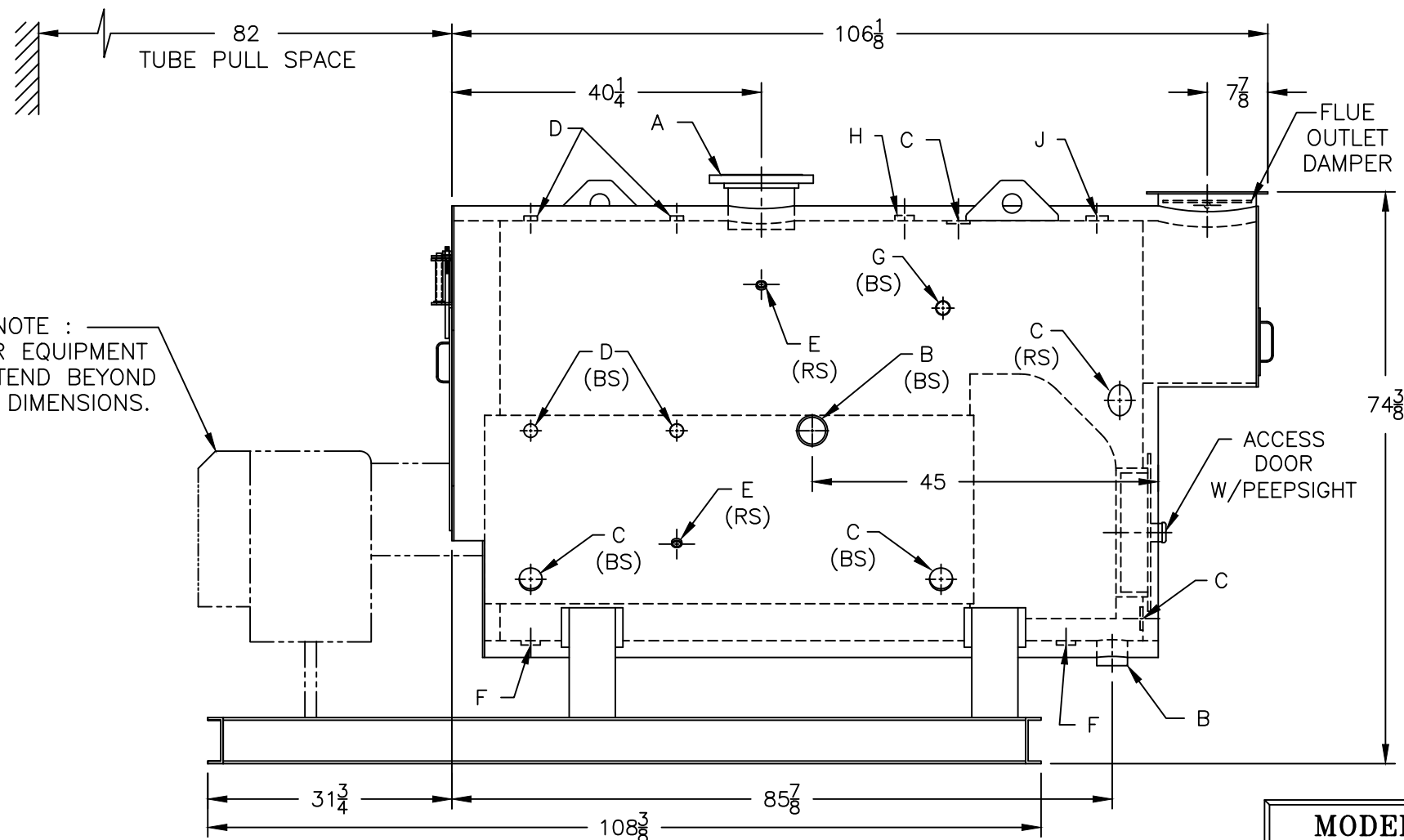

MODEL 3L-70
71.1 BHP
15 PSI STEAM

SPECIFICATIONS SUBJECT TO CHANGE WITHOUT NOTICE ALL CONNECTIONS ARE THREADED UNLESS OTHERWISE SPECIFIED
 THIS DOCUMENT CONTAINS CONFIDENTIAL INFORMATION WHICH IS THE PROPERTY OF BURNHAM COMMERCIAL. THIS DOCUMENT MAY NOT BE REPRODUCED, TRANSFERRED OR USED, OR ITS CONTENTS DISCLOSED, WITHOUT THE WRITTEN PERMISSION OF THE OWNER.