

BURNHAM®

Commercial Boilers

RATINGS AND DATA

Shell Diameter : 48"
 Gross Output - BHP : 61.7
 Gross Output - MBH : 2064
 Gross Output - Lbs/Hr : 2128
 Net Rating - MBH : 1603
 Net Rating - Sq. Ft. : 6677
 Safety Valve - Lbs/Hr. : 2400

Heating Surface - Sq. Ft.
 Fireside - 300
 Firetubes
 Number - 92
 Diameter - 2" O.D.

Firing Rate
 1000 BTU Gas (MBH) - 2511
 140000 BTU/Gal Oil (GPH) - 17.4
 150000 BTU/Gal Oil (GPH) - 16.2

Water Content
 Pounds - 2747
 Gallons (U.S.) - 329
 Approximate Weight/LBS.
 Dry - 4840
 Wet - 7587

LEGEND

BS = BOTH SIDES
 RS = RIGHT SIDE
 LS = LEFT SIDE

LEGEND CONNECTIONS

- A = 6" FLANGED SUPPLY (150#)
- B = 3" RETURN
- C = 3" x 4" HANDHOLE
- D = 1" WATER COLUMN
- E = 3/4" AQUASTAT/LFHA
- F = 1-1/2" BOTTOM BLOWDOWN
- G = 1-1/2" SURFACE BLOWOFF
- H = 1-1/2" AUXILIARY CONNECTION
- J = 2" SAFETY VALVE
- K = 10" NOMINAL FLUE DIAMETER

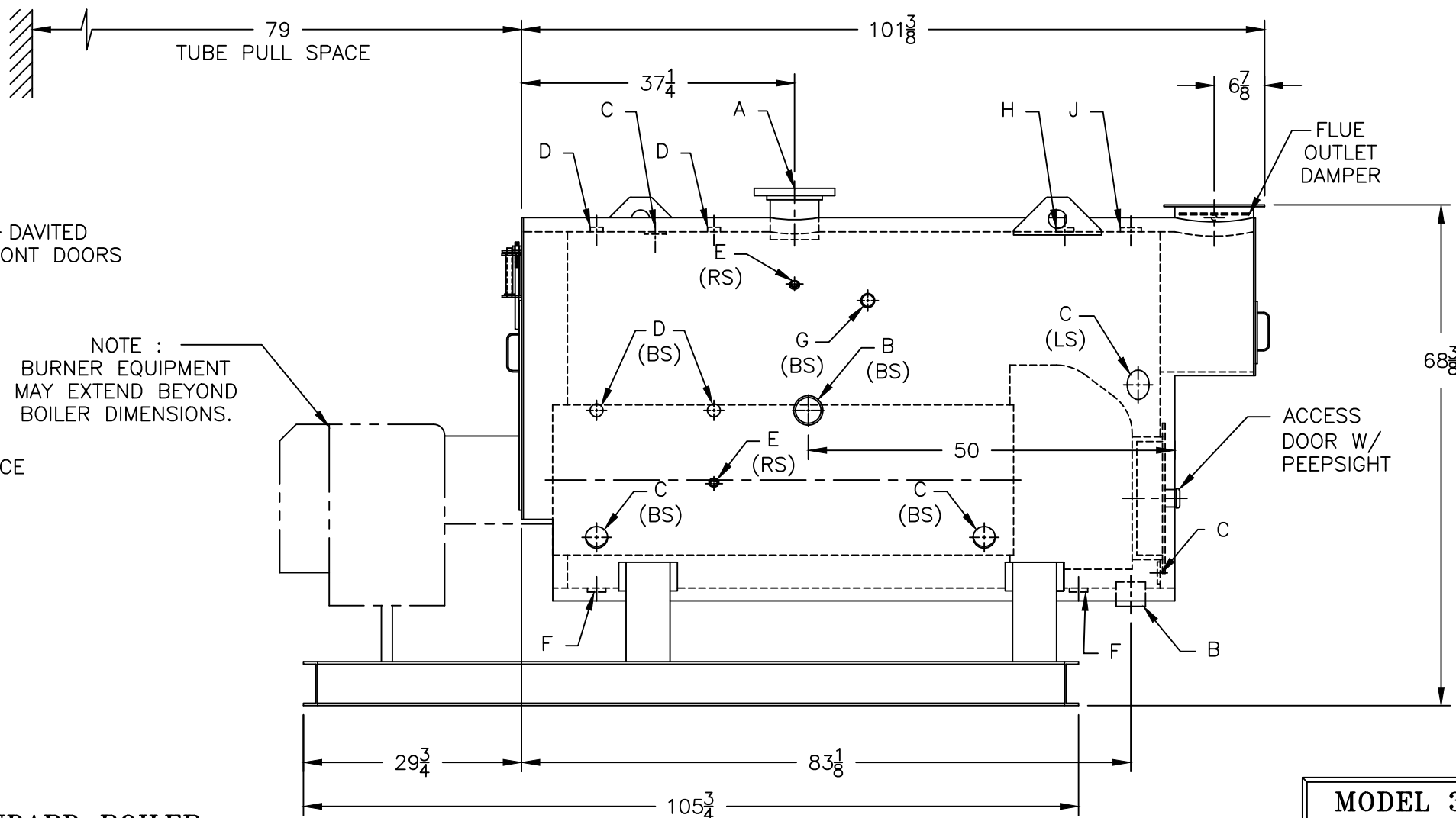
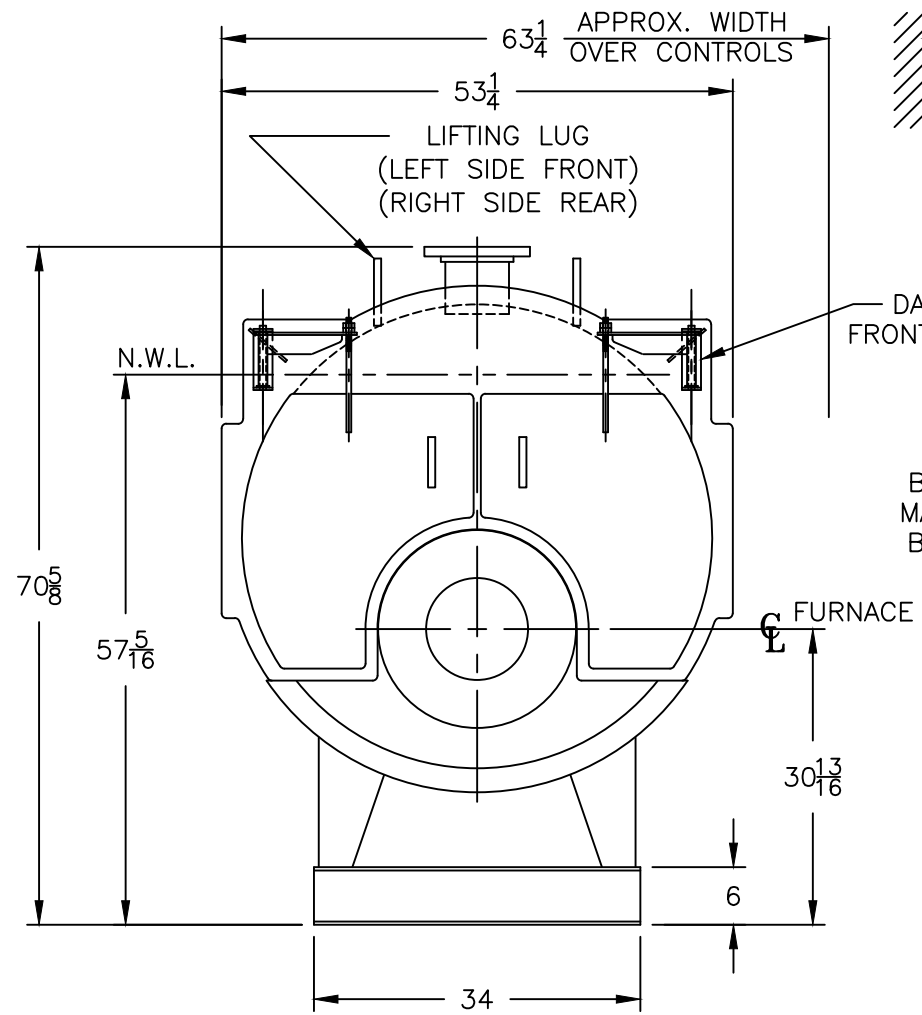
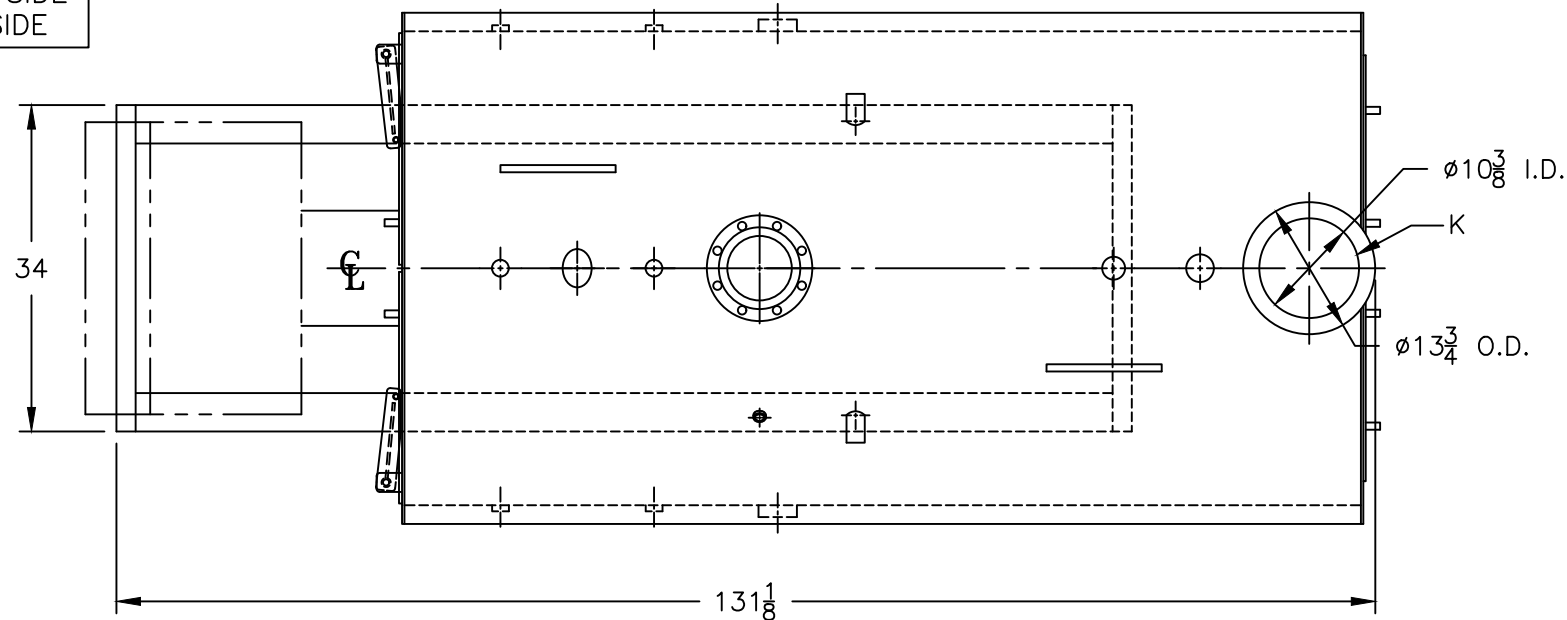

PROJECT: STANDARD BOILER

MODEL 3L-60
61.7 BHP
15 PSI STEAM