

BURNHAM®

Commercial Boilers

LEGEND CONNECTIONS

- A = 3" SUPPLY
- B = 1-1/4" RETURN
- C = 3" x 4" HANDHOLE
- D = 1" WATER COLUMN
- E = 3/4" AQUASTAT
- F = 1-1/2" BOTTOM BLOWDOWN
- G = 1-1/2" SURFACE BLOWOFF
- H = 2" AUXILIARY CONNECTION
- J = 1" SAFETY VALVE
- K = 10" NOMINAL FLUE DIAMETER

RATINGS AND DATA

Shell Diameter : 48"
 Gross Output - BHP : 40
 Gross Output - MBH : 1339
 Gross Output - Lbs/Hr : 1380
 Net Rating - MBH : 1011
 Net Rating - Sq. Ft. : 4213
 Safety Valve - Lbs/Hr. : 1562

Heating Surface - Sq. Ft.
 Fireside - 200
 Firetubes
 Number - 92
 Diameter - 2" O.D.

Firing Rate
 1000 BTU Gas (MBH) - 1674
 140000 BTU/Gal Oil (GPH) - 11.7
 150000 BTU/Gal Oil (GPH) - 10.9

Water Content
 Pounds - 1988
 Gallons (U.S.) - 239
 Approximate Weight/LBS.
 Dry - 4200
 Wet - 6188

LEGEND

BS = BOTH SIDES
 RS = RIGHT SIDE
 LS = LEFT SIDE

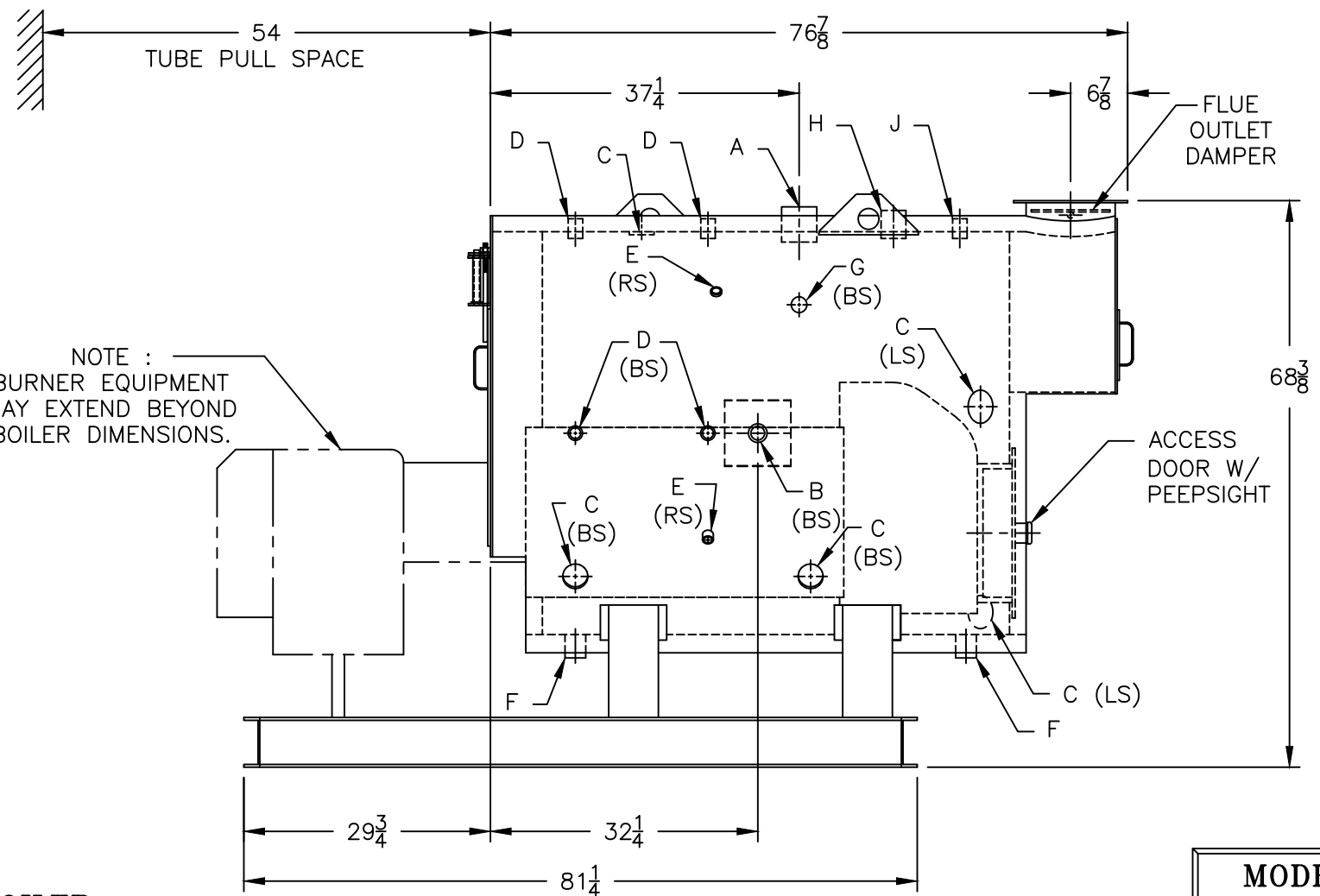
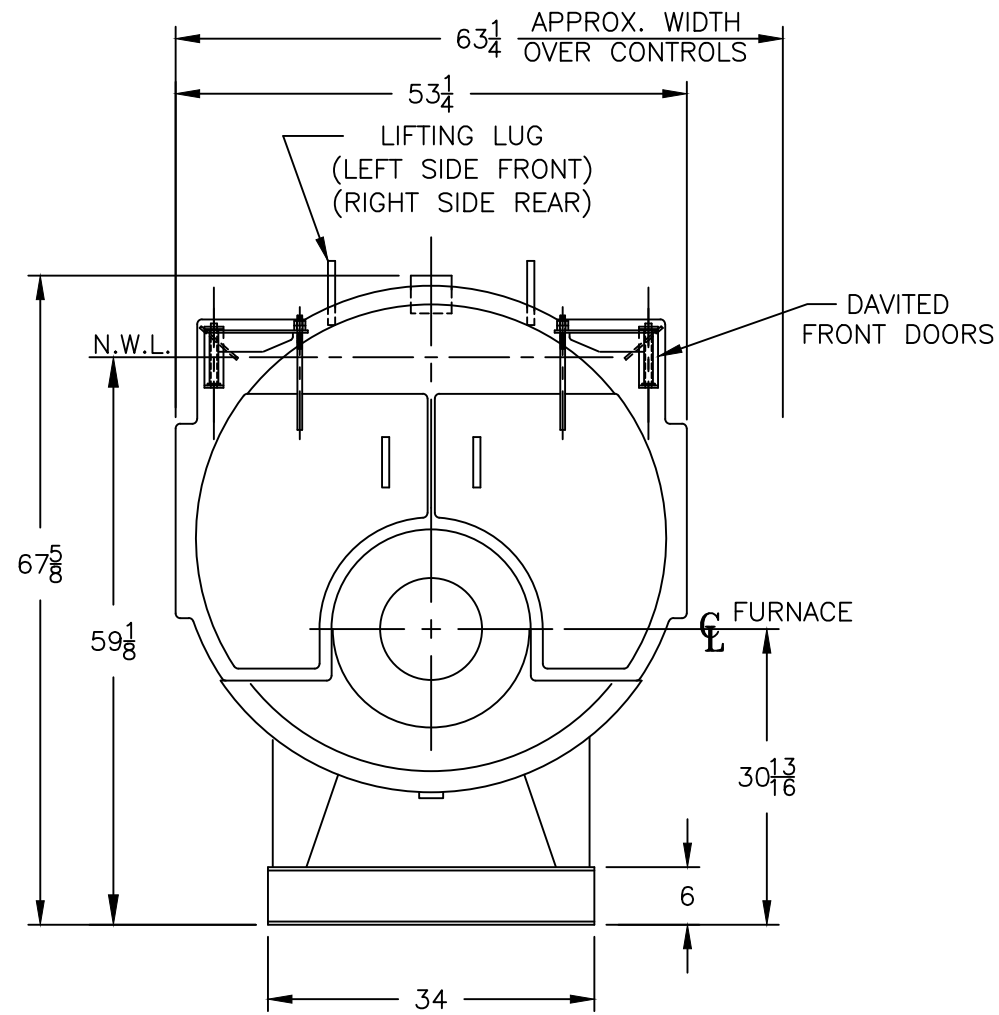
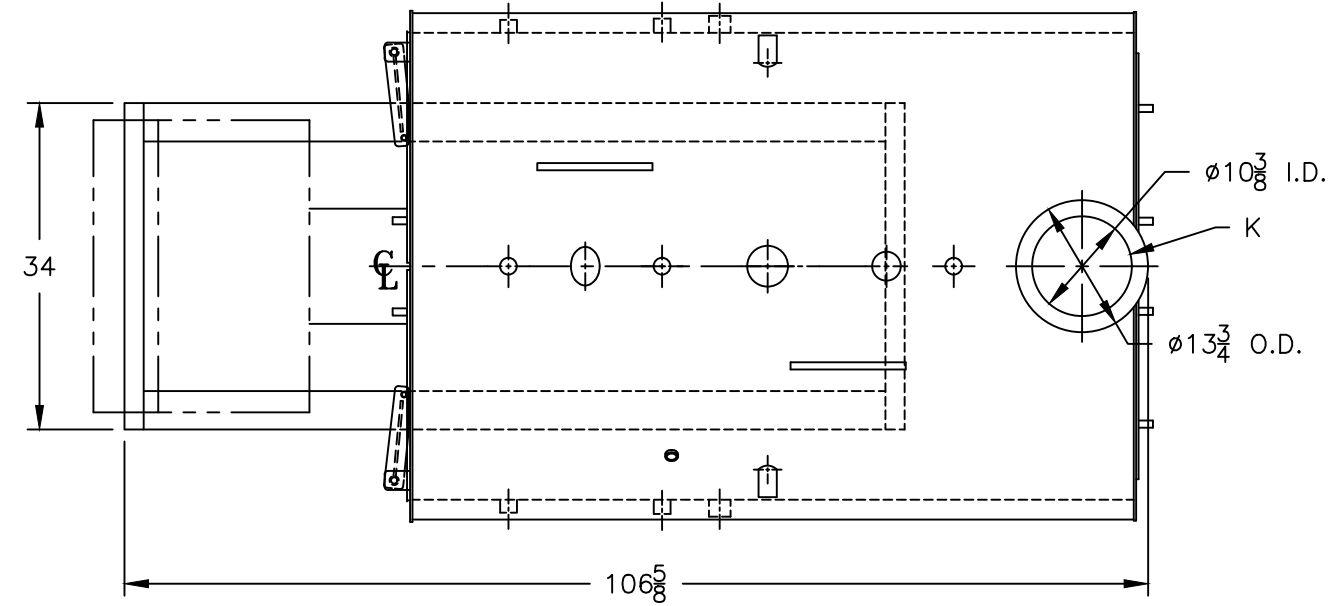

NOTE :
 BURNER EQUIPMENT
 MAY EXTEND BEYOND
 BOILER DIMENSIONS.

PROJECT: STANDARD BOILER

MODEL 3P-40
40 BHP
150 PSI STEAM