

PROJECT: STANDARD BOILER

**LEGEND**

- BS = BOTH SIDES
- RS = RIGHT SIDE
- LS = LEFT SIDE

**BURNHAM**<sup>®</sup>  
Commercial Boilers

**RATINGS AND DATA**

Shell Diameter : 90"  
Gross Output - BHP : 400  
Gross Output - MBH : 13390  
Gross Output - Lbs/Hr : 13800  
Net Rating - MBH : 10396  
Net Rating - Sq. Ft. : 43317  
Safety Valve - Lbs/Hr. : 15621

**LEGEND CONNECTIONS**

- A = 8" FLANGED SUPPLY (300#)
- B = 2-1/2" RETURN
- C = 3" x 4" HANDHOLE
- D = 1" WATER COLUMN
- E = 3/4" AQUASTAT
- F = 2" BOTTOM BLOWDOWN
- G = 2" SURFACE BLOWOFF
- H = 2" AUXILIARY CONNECTION
- J = 2" SAFETY VALVE  
1-1/2" SAFETY VALVE
- K = 12" x 16" MANHOLE
- L = 24" NOMINAL FLUE DIAMETER

Heating Surface - Sq. Ft.  
Fireside - 2000  
Firetubes  
Number - 268  
Diameter - 2.5" O.D.

Firing Rate  
1000 BTU Gas (MBH) - 16738  
140000 BTU/Gal Oil (GPH) - 114.8  
150000 BTU/Gal Oil (GPH) - 107.1

Water Content  
Pounds - 16497  
Gallons (U.S.) - 1981  
Approximate Weight/LBS.  
(Includes Economizer)  
Dry - 27306  
Wet - 43803

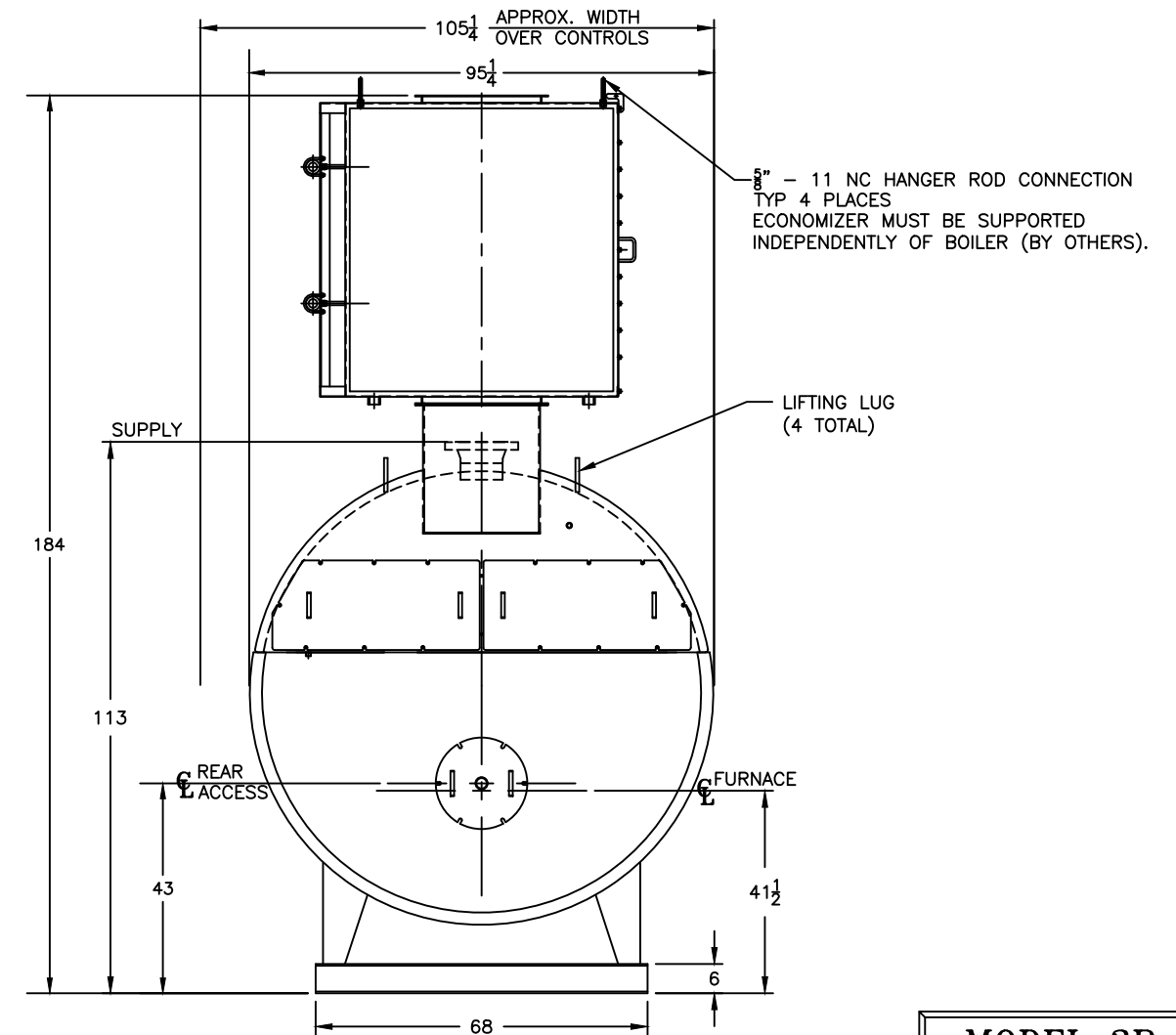
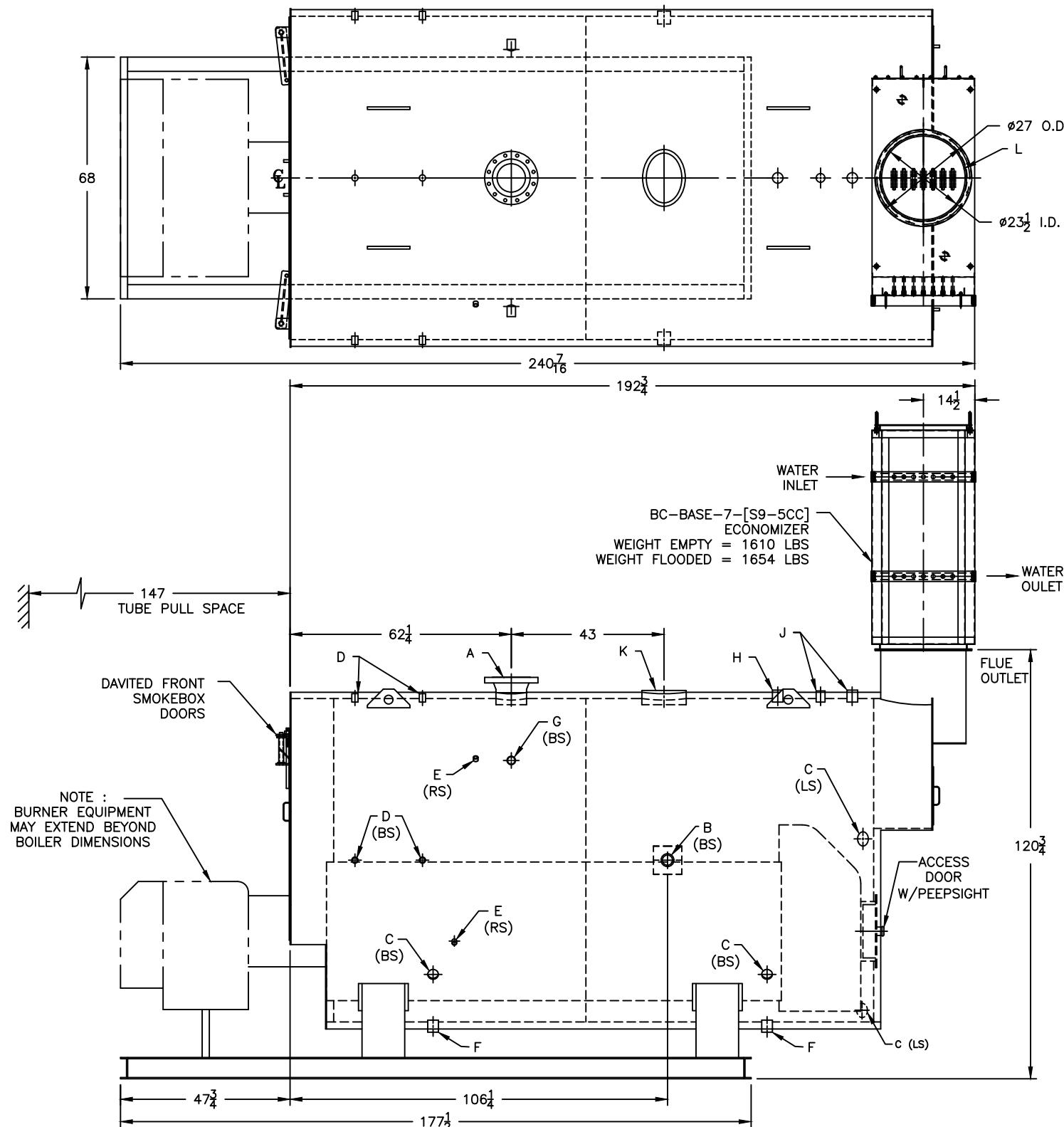

**MODEL 3P-400**  
**400 BHP**  
**150 PSI STEAM**

SPECIFICATIONS SUBJECT TO CHANGE WITHOUT NOTICE ALL CONNECTIONS ARE THREADED UNLESS OTHERWISE SPECIFIED

THIS DOCUMENT CONTAINS CONFIDENTIAL INFORMATION WHICH IS THE PROPERTY OF BURNHAM COMMERCIAL. THIS DOCUMENT MAY NOT BE REPRODUCED, TRANSFERRED OR USED, OR ITS CONTENTS DISCLOSED, WITHOUT THE WRITTEN PERMISSION OF THE OWNER.