

# BURNHAM®

## Commercial Boilers

### RATINGS AND DATA

Shell Diameter : 78"  
 Gross Output - BHP : 260.3  
 Gross Output - MBH : 8714  
 Net Rating - MBH : 7577  
 Safety Valve - MBH : 10000

Heating Surface - Sq. Ft.  
 Fireside - 1250  
 Firetubes  
 Number - 186  
 Diameter - 2.5" O.D.

Firing Rate  
 1000 BTU Gas (MBH) - 10461  
 140,000 BTU/GAL Oil (GPH) - 71.7  
 150,000 BTU/GAL Oil (GPH) - 66.9

Water Content  
 Pounds - 13618  
 Gallons (U.S.) - 1635  
 Approximate Weight/LBS.  
 Dry - 17700  
 Wet - 31318

### LEGEND

BS = BOTH SIDES  
 RS = RIGHT SIDE  
 LS = LEFT SIDE

### LEGEND CONNECTIONS

- A = 6" FLANGED SUPPLY (150#)
- B = 6" FLANGED RETURN (150#)
- C = 3" x 4" HANDHOLE
- D = 1" WATER COLUMN
- E = 3/4" AQUASTAT
- F = 2" BOTTOM DRAIN
- G = 2" EXPANSION TANK
- H = 3/4" TEMPERATURE GAUGE
- J = 2" RELIEF VALVE
- K = 12" x 16" MANHOLE
- L = 20" NOMINAL FLUE DIAMETER

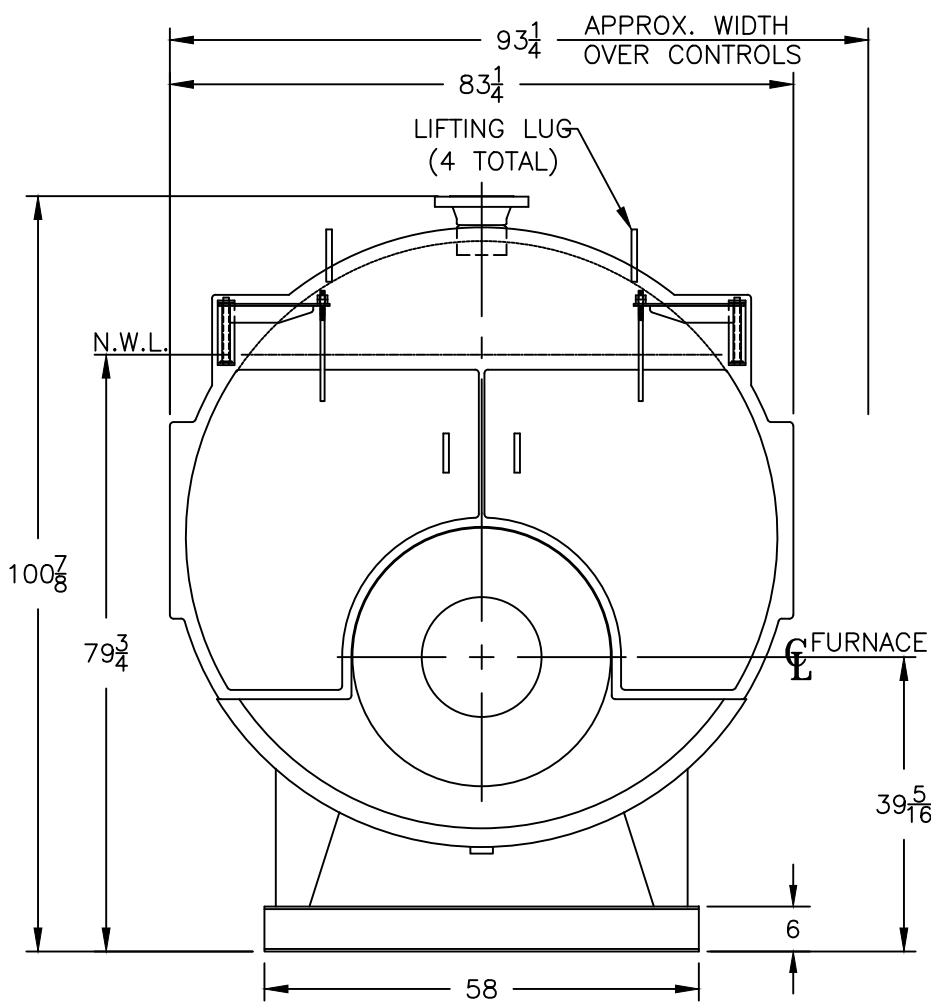
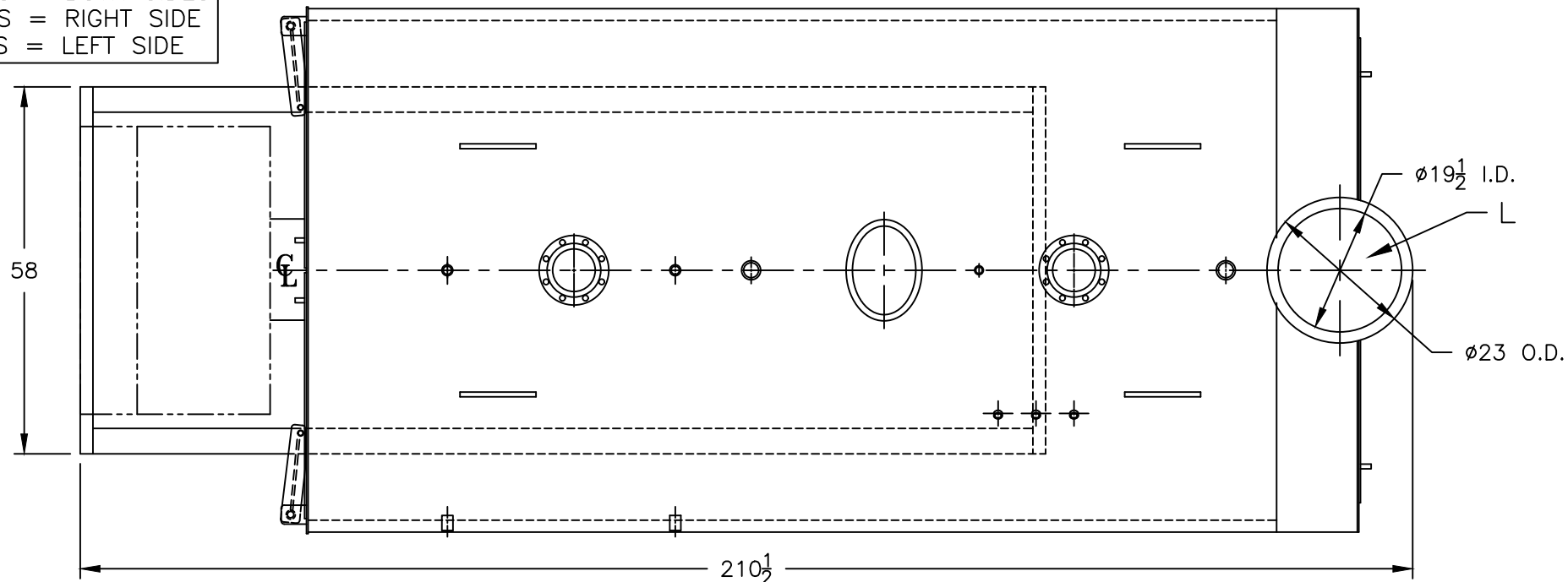

PROJECT: STANDARD BOILER

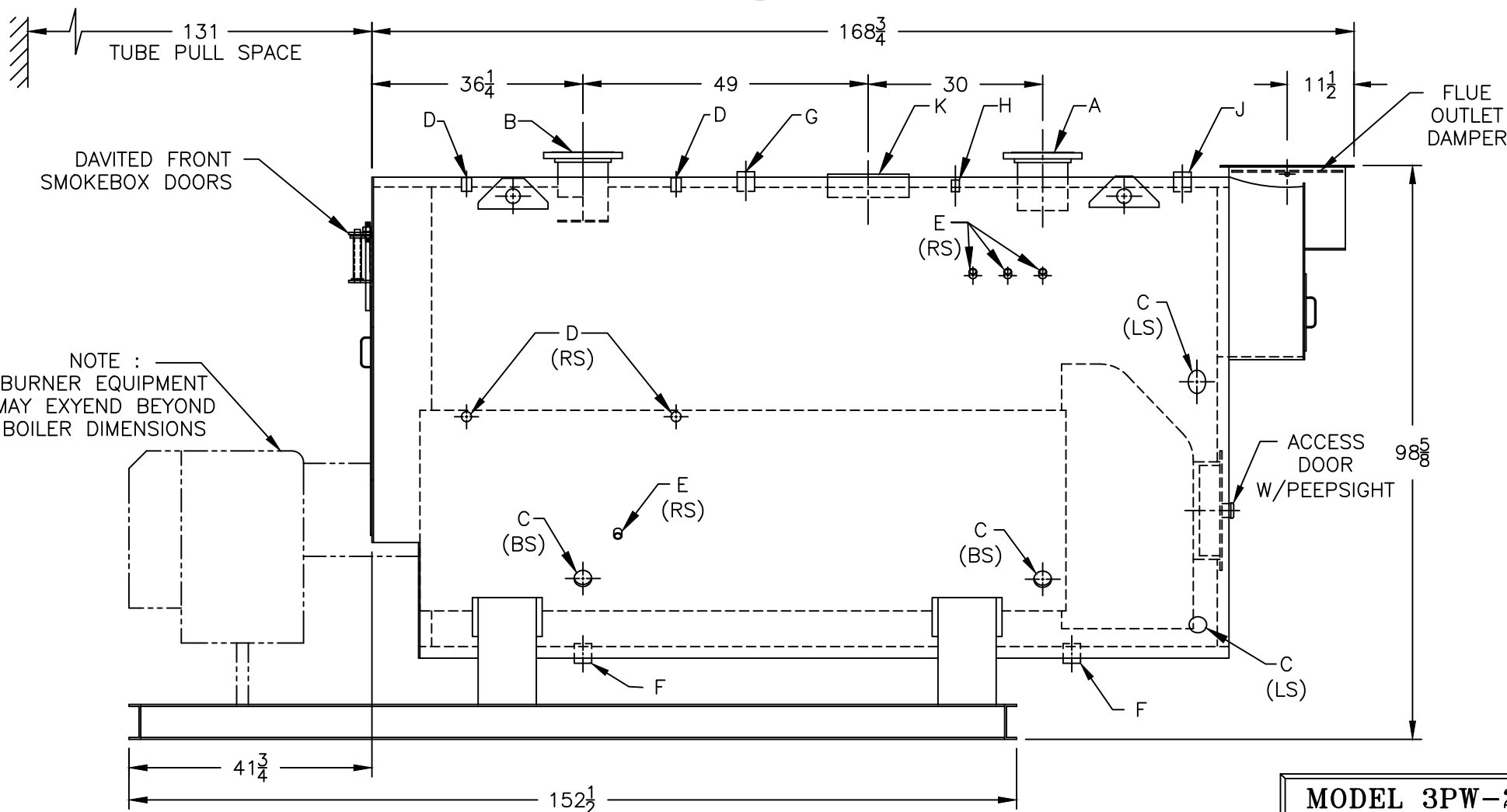

NOTE :  
 BURNER EQUIPMENT  
 MAY EXYEND BEYOND  
 BOILER DIMENSIONS

**MODEL 3PW-250**  
**260.3 BHP**  
**125 PSI WATER**