

BURNHAM®

Commercial Boilers

RATINGS AND DATA

Shell Diameter : 48"
 Gross Output - BHP : 62.3
 Gross Output - MBH : 2087
 Net Rating - MBH : 1814
 Safety Valve - MBH. : 2400

Heating Surface - Sq. Ft.
 Fireside - 300
 Firetubes
 Number - 92
 Diameter - 2" O.D.

Firing Rate
 1000 BTU Gas (MBH) - 2511
 140000 BTU/Gal Oil (GPH) - 17.4
 150000 BTU/Gal Oil (GPH) - 16.2

Water Content
 Pounds - 3230
 Gallons (U.S.) - 388
 Approximate Weight/LBS.
 Dry - 5790
 Wet - 9025

LEGEND

BS = BOTH SIDES
 RS = RIGHT SIDE
 LS = LEFT SIDE

LEGEND CONNECTIONS

- A = 4" SUPPLY
- B = 4" RETURN
- C = 3" x 4" HANDHOLE
- D = 1" WATER COLUMN
- E = 3/4" AQUASTAT/LFHA
- F = 1-1/2" BOTTOM BLOWDOWN
- G = 1-1/2" AUXILIARY CONNECTION
- H = 1" RELIEF VALVE
- J = 3/4" TEMPERATURE GAUGE
- K = 10" NOMINAL FLUE DIAMETER

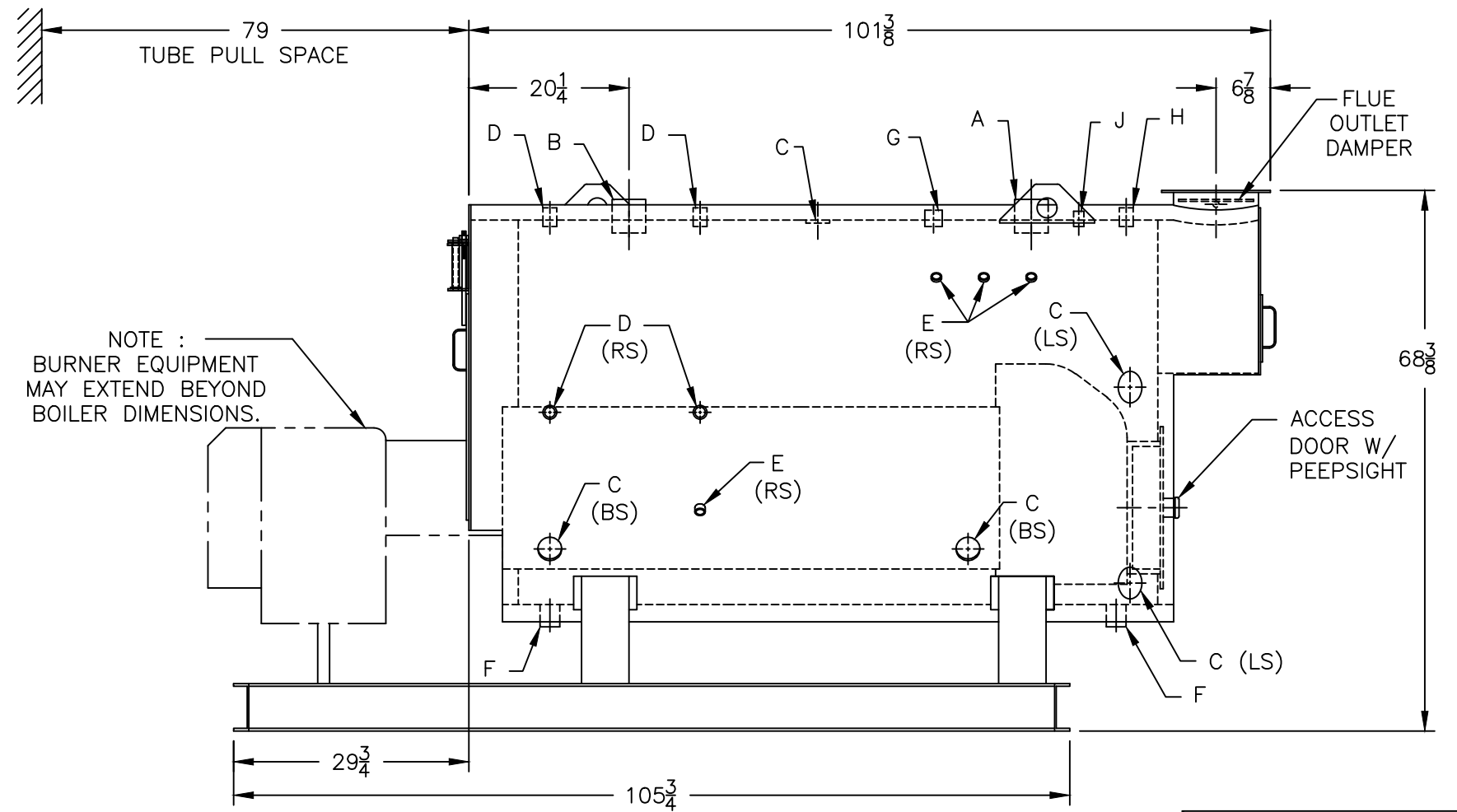
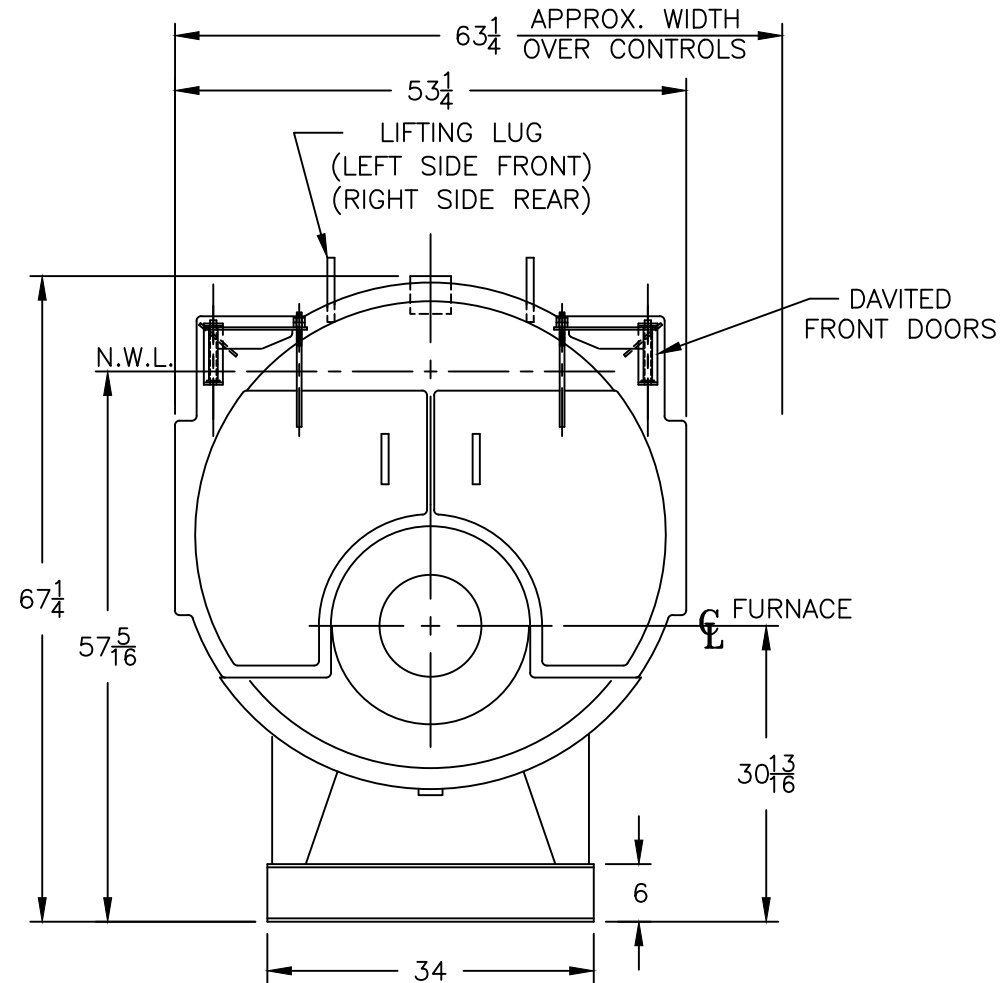
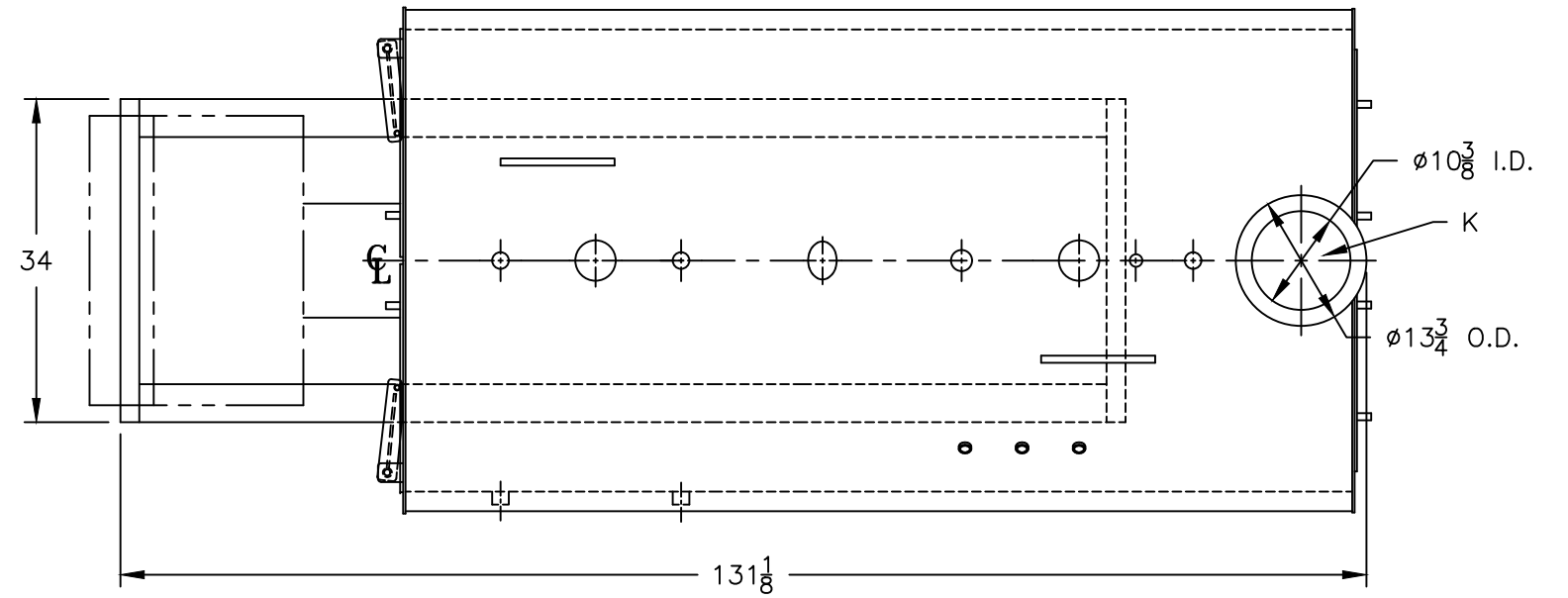

PROJECT: STANDARD BOILER

MODEL 3PW-60
62.3 BHP
125 PSI WATER