

BURNHAM®

Commercial Boilers

RATINGS AND DATA

Shell Diameter : 54"
 Gross Output - BHP : 82.8
 Gross Output - MBH : 2772
 Net Rating - MBH : 2411
 Relief Valve - MBH : 3200

Heating Surface - Sq. Ft.
 Fireside - 400

Firetubes
 Number - 106
 Diameter - 2" O.D.

Firing Rate
 1000 BTU Gas (MBH) - 3348
 140000 BTU/Gal Oil (GPH) - 23.0
 150000 BTU/Gal Oil (GPH) - 21.5

Water Content
 Pounds - 4707
 Gallons (U.S.) - 565
 Approximate Weight/LBS.
 Dry - 6700
 Wet - 11407

LEGEND

BS = BOTH SIDES
 RS = RIGHT SIDE
 LS = LEFT SIDE

LEGEND CONNECTIONS

A = 4" SUPPLY
 B = 4" RETURN
 C = 3" x 4" HANDHOLE
 D = 1" WATER COLUMN
 E = 3/4" AQUASTAT
 F = 1-1/2" BOTTOM BLOWDOWN
 G = 1-1/2" AUXILIARY CONN.
 H = 3/4" TEMPERATURE GAUGE
 J = 1-1/4" RELIEF VALVE
 K = 12" NOMINAL FLUE DIAMETER

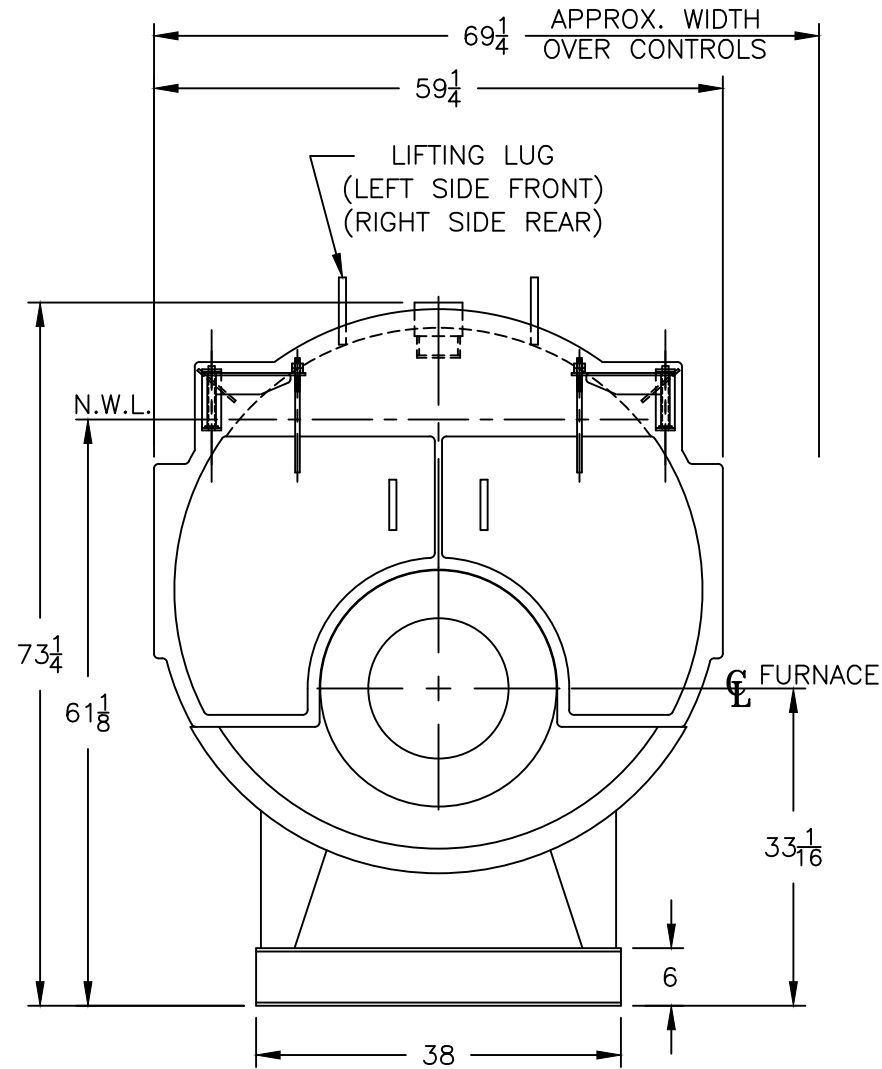
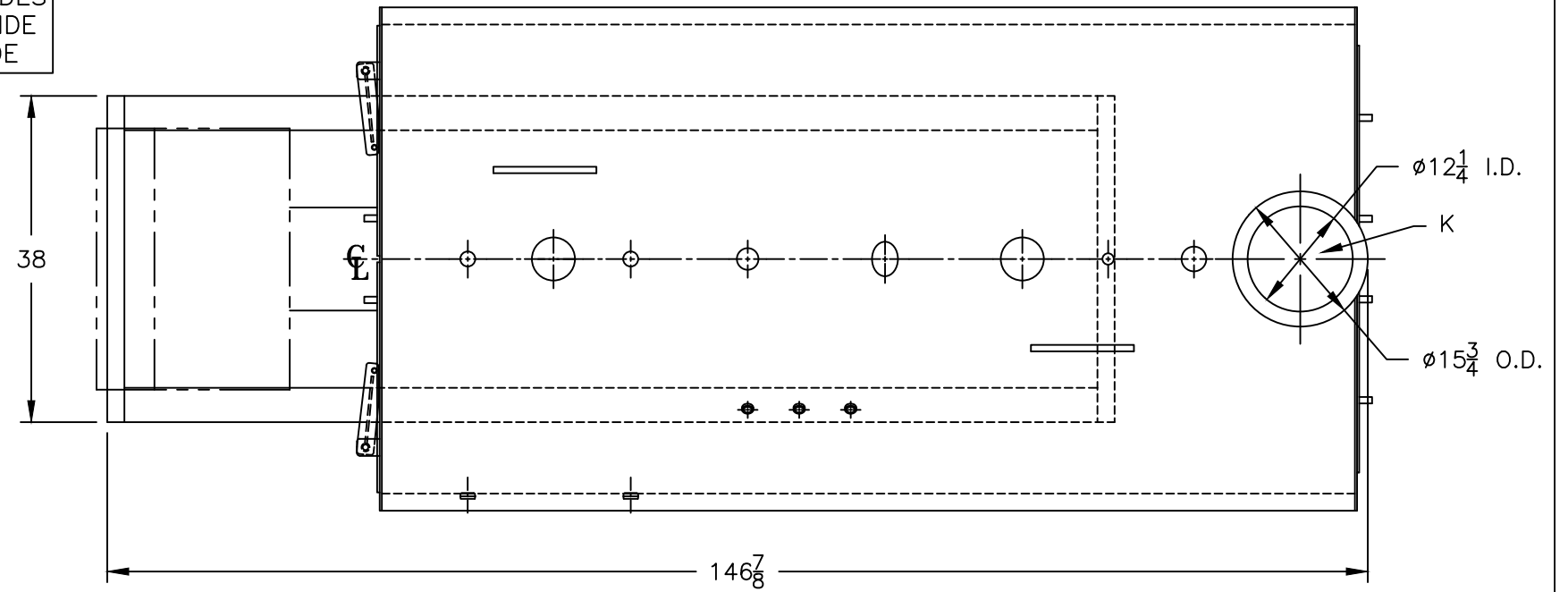

PROJECT: STANDARD BOILER

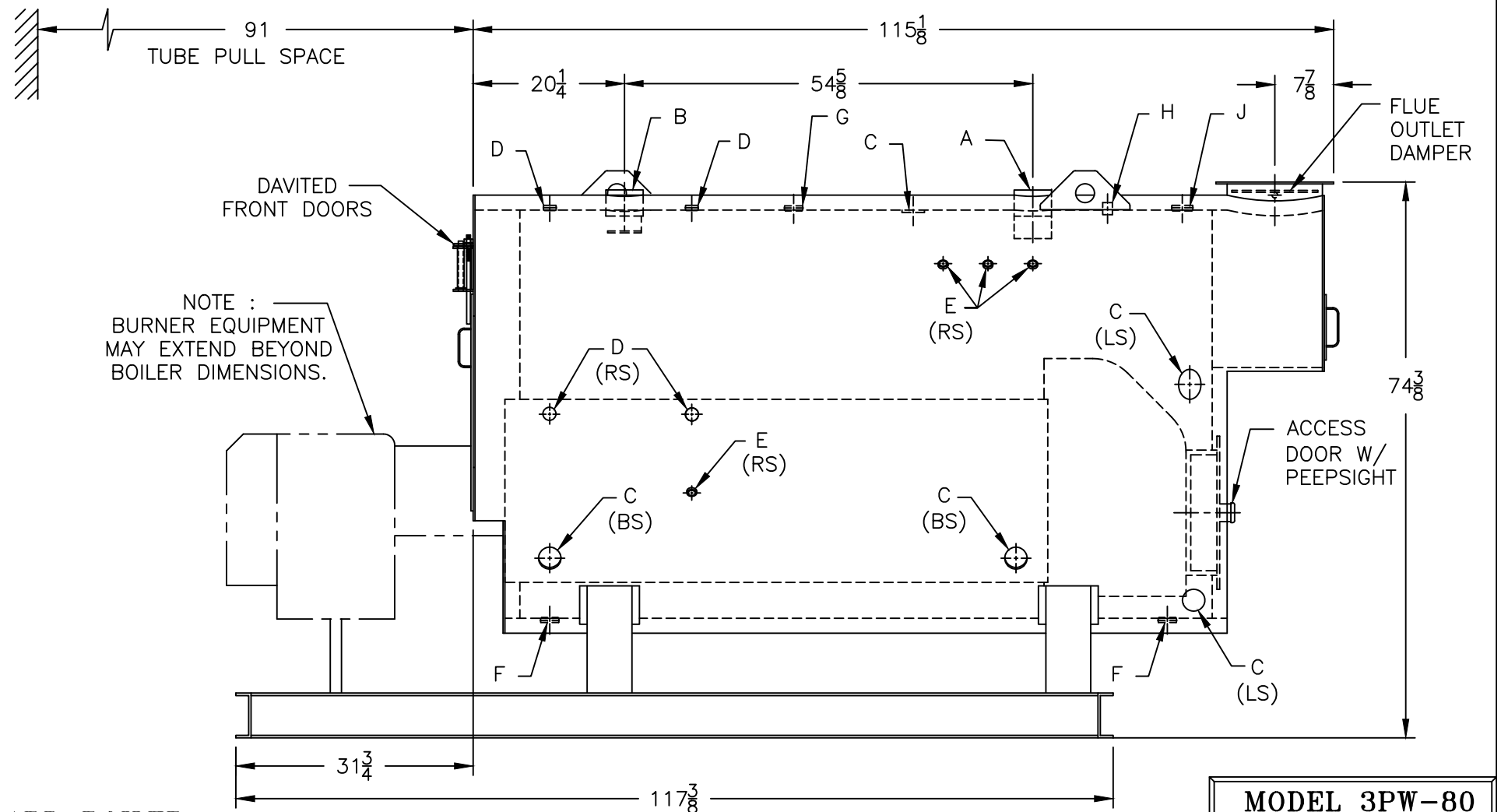

MODEL 3PW-80
82.8 BHP
125 PSI WATER

SPECIFICATIONS SUBJECT TO CHANGE WITHOUT NOTICE ALL CONNECTIONS ARE THREADED UNLESS OTHERWISE SPECIFIED

THIS DOCUMENT CONTAINS CONFIDENTIAL INFORMATION WHICH IS THE PROPERTY OF BURNHAM COMMERCIAL. THIS DOCUMENT MAY NOT BE REPRODUCED, TRANSFERRED OR USED, OR ITS CONTENTS DISCLOSED, WITHOUT THE WRITTEN PERMISSION OF THE OWNER.