

BURNHAM®

Commercial Boilers

RATINGS AND DATA

Shell Diameter : 108"
 Gross Output - BHP : 800
 Gross Output - MBH : 26780
 Net Rating - MBH : 23287
 Relief Valve - Lbs/Hr. : 32000

Heating Surface - Sq. Ft.
 Fireside - 4000

Firetubes
 Number - 338
 Diameter - 2.5" O.D.

Firing Rate
 1000 BTU Gas (MBH) - 33475
 140000 BTU/Gal Oil (GPH) - 239.1
 150000 BTU/Gal Oil (GPH) - 223.2

Water Content
 Pounds - 44100
 Gallons (U.S.) - 5287
 Approximate Weight/LBS.
 Dry - 52900
 Wet - 97000

LEGEND CONNECTIONS

- A = 10" FLANGED SUPPLY (150#)
- B = 10" FLANGED RETURN (150#)
- C = 3" x 4" HANDHOLE
- D = 1" WATER COLUMN
- E = 3/4" AQUASTAT
- F = 2" BOTTOM DRAIN
- G = 2" AUXILIARY CONNECTION
- H = 3/4" TEMPERATURE GAUGE
- J = 2" RELIEF VALVE (2)
- K = 12" x 16" MANHOLE
- L = 34" NOMINAL FLUE DIAMETER

LEGEND

- BS = BOTH SIDES
- RS = RIGHT SIDE
- LS = LEFT SIDE

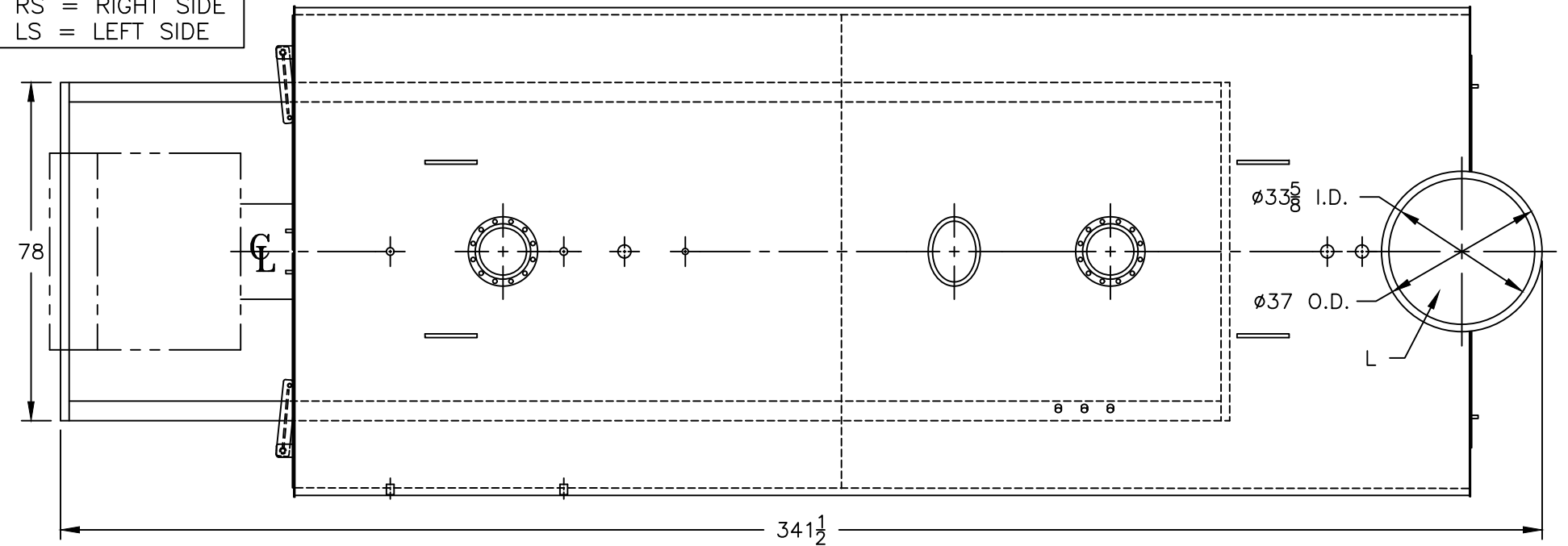

PROJECT: STANDARD BOILER

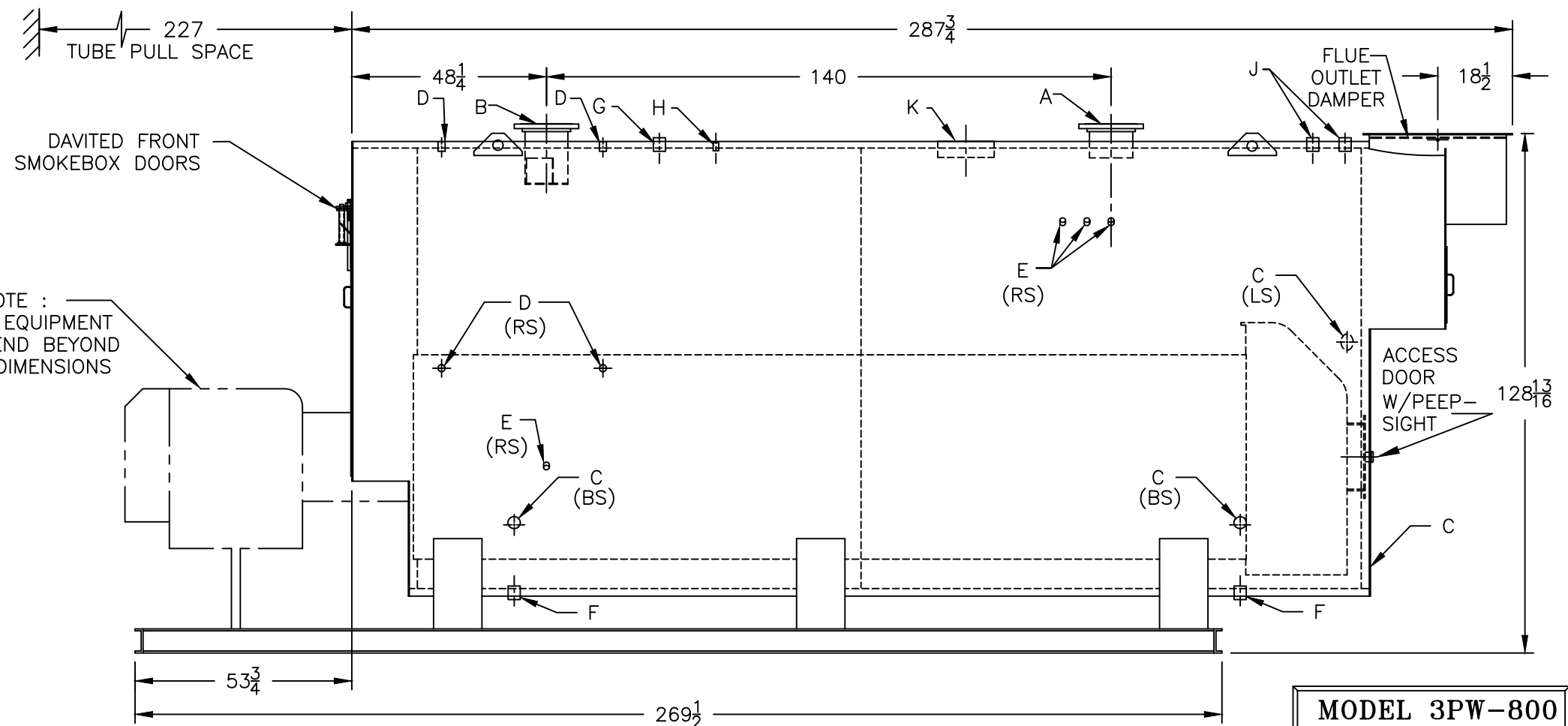
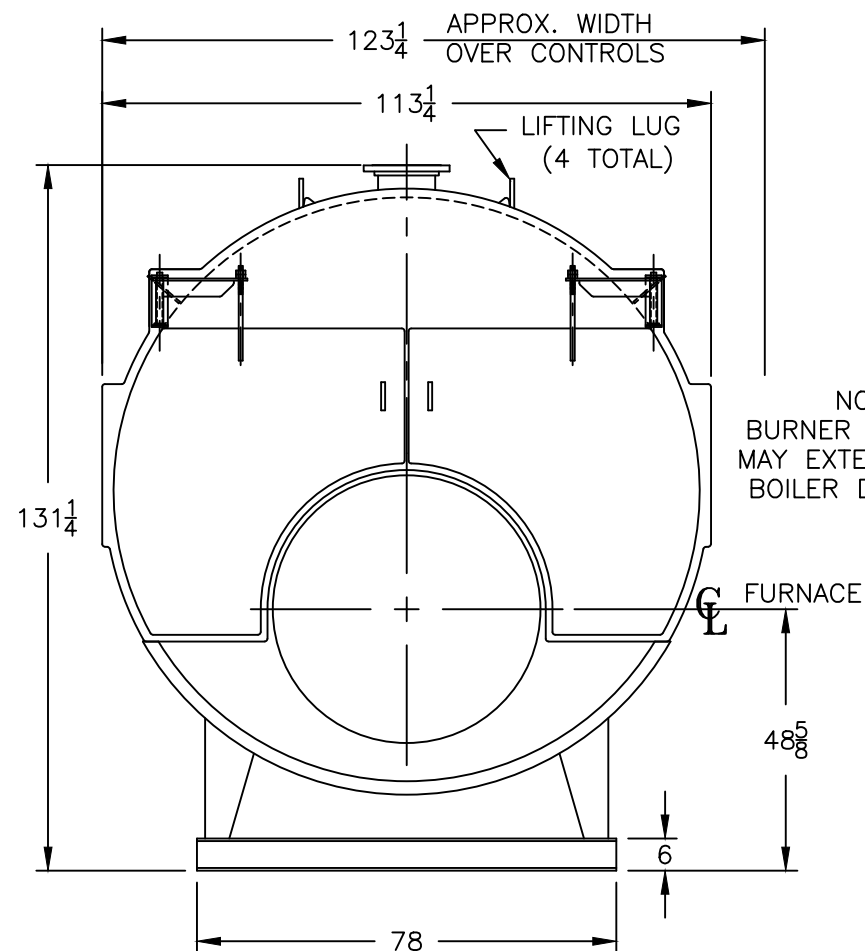

SPECIFICATIONS SUBJECT TO CHANGE WITHOUT NOTICE
 ALL CONNECTIONS ARE THREADED UNLESS OTHERWISE SPECIFIED

MODEL 3PW-800
800 BHP
125 PSI WATER