

BURNHAM®

Commercial Boilers

LEGEND CONNECTIONS

- A = 8" FLANGED SUPPLY (150#)
- B = 8" FLANGED RETURN (150#)
- C = 3" x 4" HANDHOLE
- D = 1" WATER COLUMN
- E = 3/4" AQUASTAT
- F = 2" BOTTOM DRAIN
- G = 2" EXPANSION TANK
- H = 3/4" TEMPERATURE GAUGE
- J = 1-1/4" RELIEF VALVE (1)
2" RELIEF VALVE (2)
- K = 12" x 16" MANHOLE
- L = 24" NOMINAL FLUE DIAMETER

RATINGS AND DATA

Shell Diameter : 90"
 Gross Output - BHP : 363.1
 Gross Output - MBH : 12155
 Net Rating - MBH : 10570
 Relief Valve - MBH : 14000

Heating Surface - Sq. Ft.
 Fireside - 1750

Firetubes
 Number - 268
 Diameter - 2.5" O.D.

Firing Rate
 1000 BTU Gas (MBH) - 14645
 140000 BTU/Gal Oil (GPH) - 100.1
 150000 BTU/Gal Oil (GPH) - 93.4

Water Content
 Pounds - 17620
 Gallons (U.S.) - 2115
 Approximate Weight/LBS.
 Dry - 21000
 Wet - 38620

LEGEND

BS = BOTH SIDES
 RS = RIGHT SIDE
 LS = LEFT SIDE

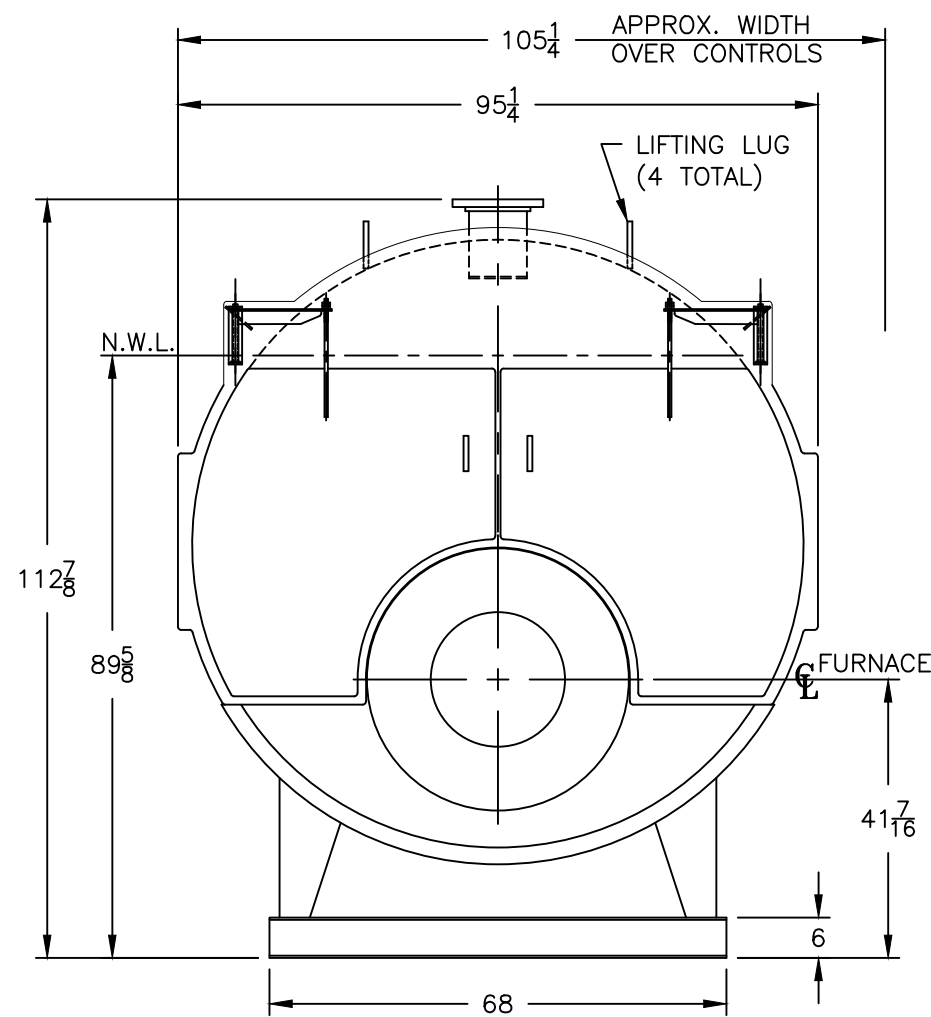
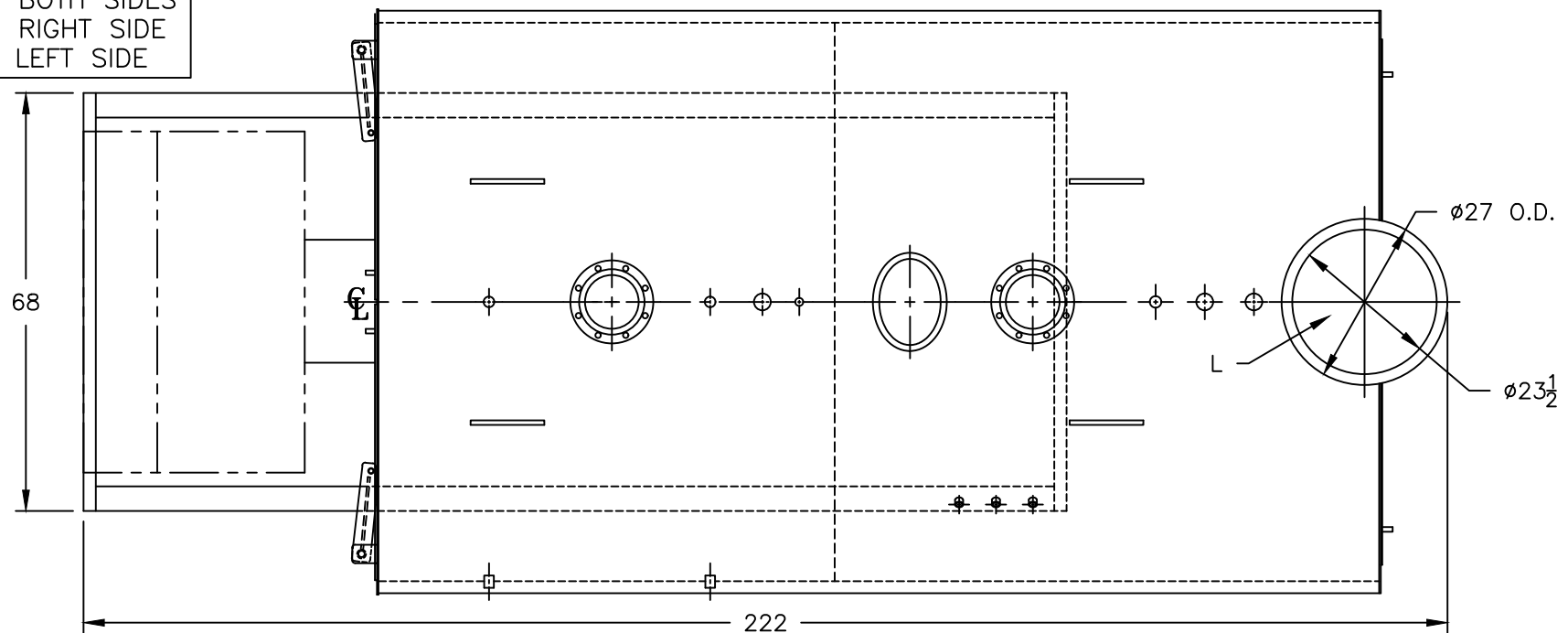

PROJECT: STANDARD BOILER

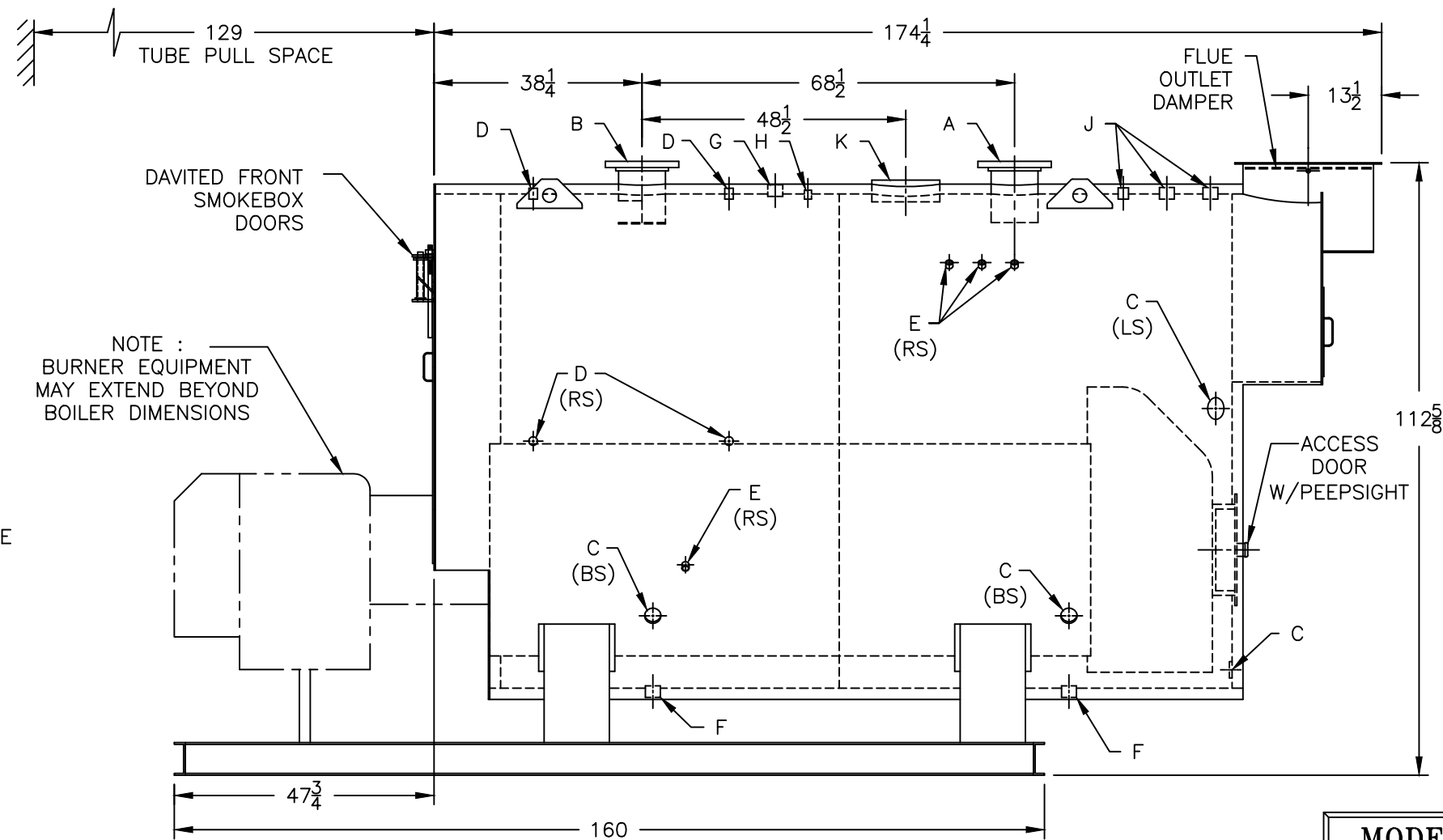

MODEL 3W-350
363.1 BHP
30 PSI WATER