

BURNHAM®

Commercial Boilers

RATINGS AND DATA

Shell Diameter : 54"
 Gross Output - BHP : 71.7
 Gross Output - MBH : 2402
 Net Rating - MBH : 2089
 Relief Valve - MBH : 2800

Heating Surface - Sq. Ft.
 Fireside - 350

Firetubes
 Number - 106
 Diameter - 2" O.D.

Firing Rate
 1000 BTU Gas (MBH) - 2929
 140000 BTU/Gal Oil (GPH) - 20.1
 150000 BTU/Gal Oil (GPH) - 18.8

Water Content
 Pounds - 4165
 Gallons (U.S.) - 499
 Approximate Weight/LBS.
 Dry - 5500
 Wet - 9665

LEGEND

BS = BOTH SIDES
 RS = RIGHT SIDE
 LS = LEFT SIDE

LEGEND CONNECTIONS

A = 4" SUPPLY
 B = 4" RETURN
 C = 3" x 4" HANDHOLE
 D = 1" WATER COLUMN
 E = 3/4" AQUASTAT
 F = 1-1/2" BOTTOM BLOWDOWN
 G = 1-1/2" EXPANSION TANK
 H = 3/4" TEMPERATURE GAUGE
 J = 2" SAFETY/RELIEF VALVE
 K = 12" NOMINAL FLUE DIAMETER

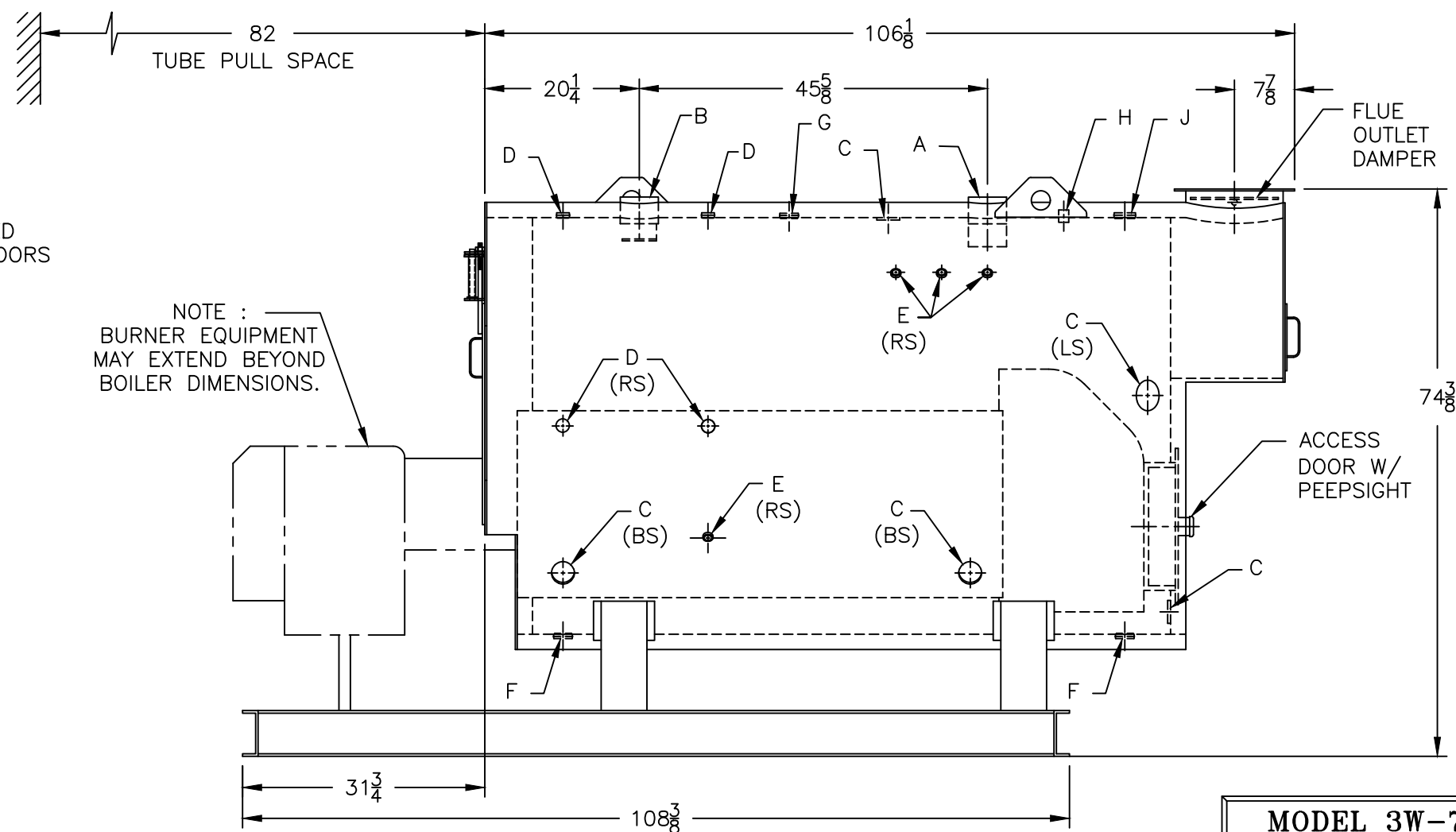
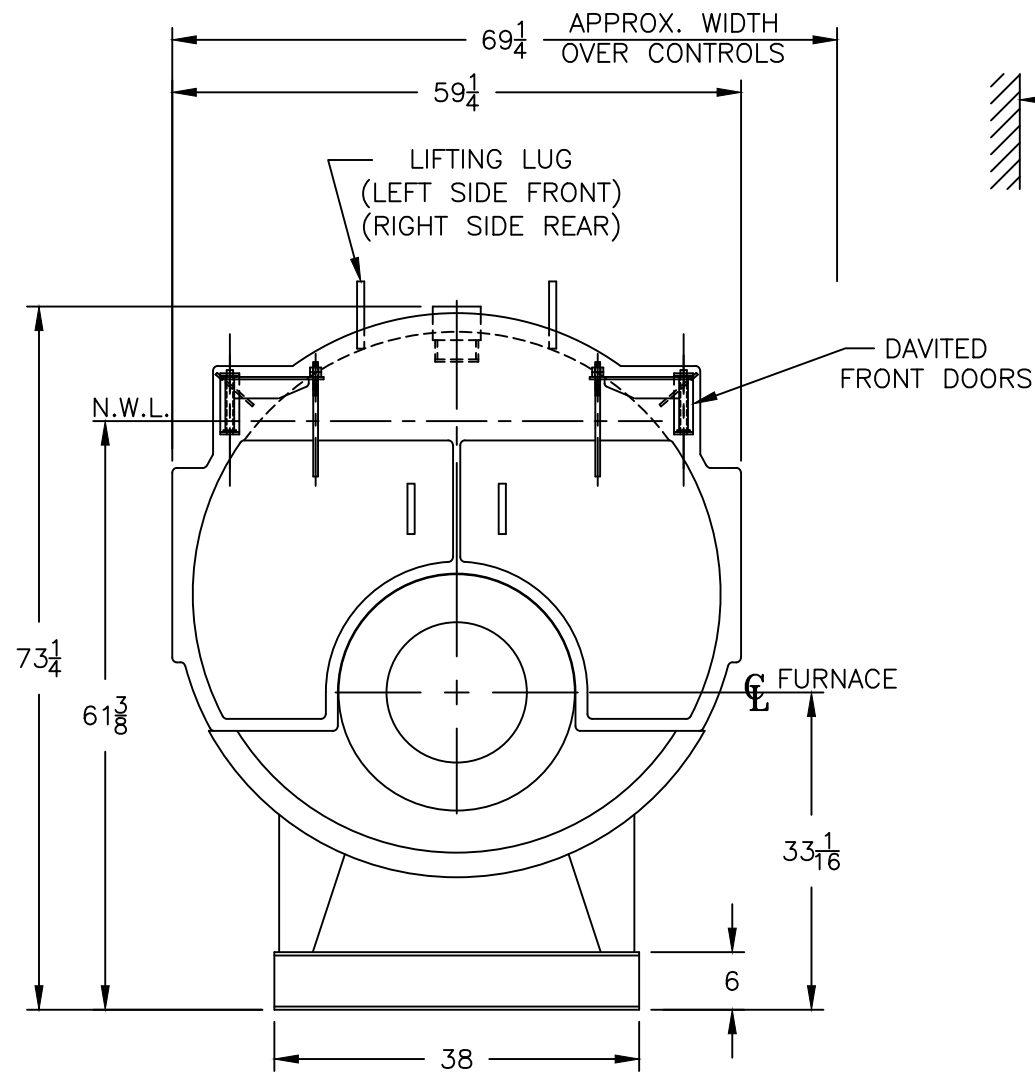
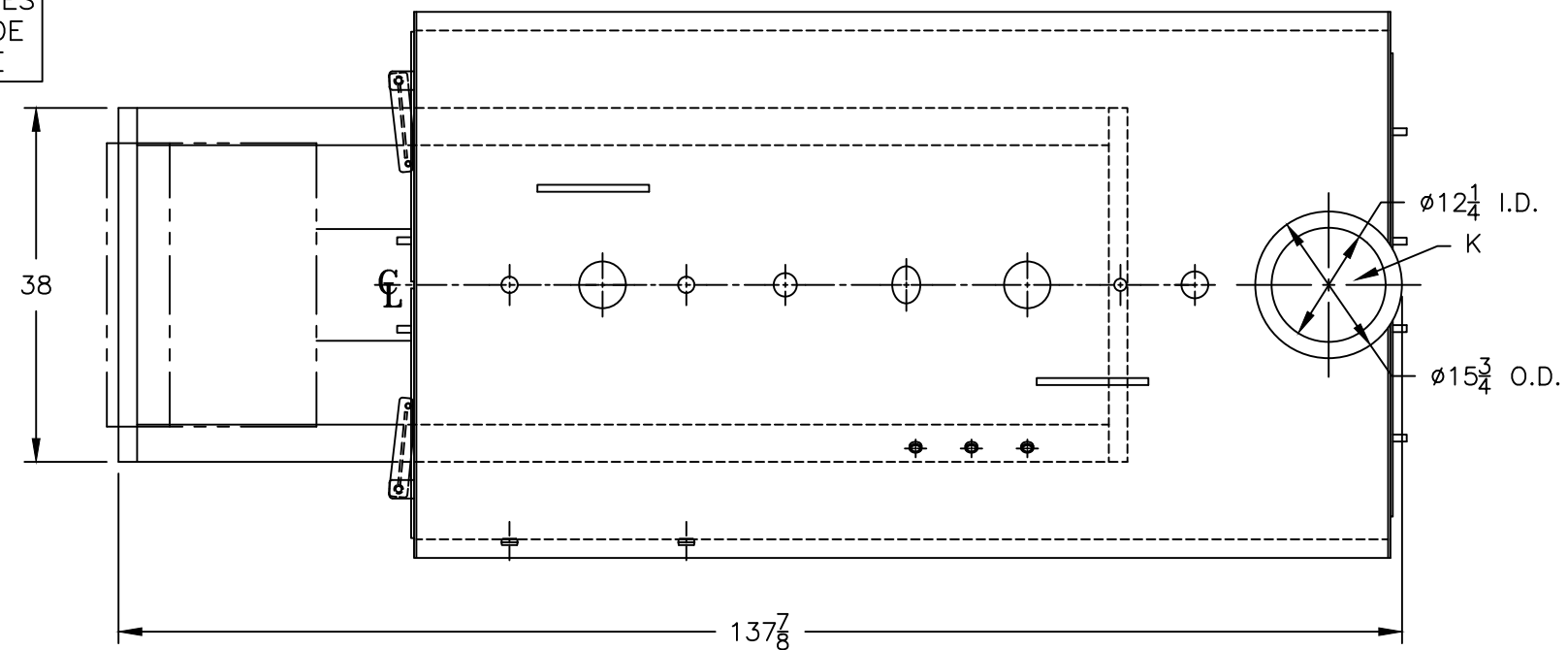

PROJECT: STANDARD BOILER

MODEL 3W-70
71.7 BHP
30 PSI WATER